

2 CYLINDER ALUMINUM TRUCK
 FRAME: ALUMINUM
 TUBING: 1 SCH 40 AL PIPE
 BRAKE: YES
 LOAD CAPACITY: 600 LBS
 HEIGHT: 50"
 WIDTH: 23"
 DEPTH: 25-3/4"
 SHOE SIZE: 19" WIDE X 14" DEEP
 11-3/4" X 19" USEABLE SHOE SIZE

PROPRIETARY AND CONFIDENTIAL

THE INFORMATION CONTAINED IN THIS DRAWING IS THE SOLE PROPERTY OF VALLEY CRAFT. ANY REPRODUCTION IN PART OR AS A WHOLE WITHOUT THE WRITTEN PERMISSION OF VALLEY CRAFT IS PROHIBITED.

UNLESS OTHERWISE SPECIFIED:

DECIMALS
 2 PLACES ±0.01
 3 PLACES ±0.005
 ANGLE ±1°

GRIND/SAND SHARP EDGES .015 MAX DOES NOT APPLY TO DRILLED HOLE DIA.



TITLE: TRK-CYL/1620AA

SIZE PART NO.
 A F86065A6

MATL:

SCALE: 1:16 **WEIGHT:** **SHEET 1 OF 3**

A	305266	DRAWN FROM CADKEY	TSH	4/23/2015
CHG.	E.C.O.	DESCRIPTION / WAS	BY	DATE

ALL ANGLES ARE 90° UNLESS SPECIFIED

Not Modeled
 F60221A2: BRAKE CABLE ASSEMBLY Qty. 1
 Z30159A5: COMPRESSION SPRING 9/16 X 2-1/4 Qty. 2
 Z30160A2: COMPRESSION SPRING 1 X 11-3/8 Qty. 2

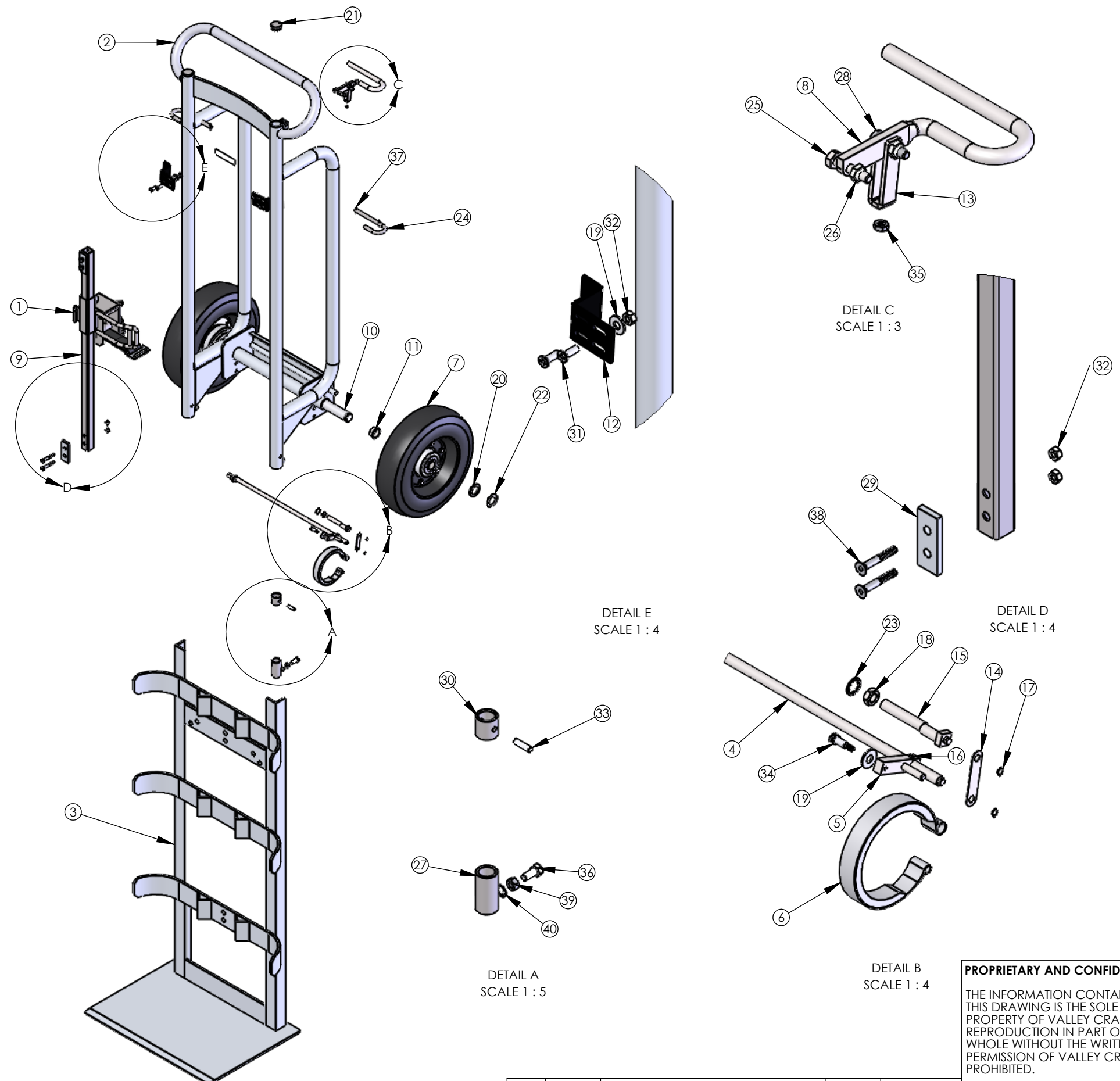

ITEM NO.	PART NUMBER	DESCRIPTION	QTY.
1	F60896A6	RSA ASSY	1
2	F60525A5	F W/1620AA	1
3	F61246A1	SHOE WLDMT-SL/1600A	1
4	F68894A6	BRK ROD WLDMT-18.13	1
5	F68656A4	BRK ROD PIN WLDMT	1
6	F62177A2	BRK BAND ASSY	2
7	F60032A1	WHL-12 AIR BRK	2
8	F30047A7	HDL-BRK/LOOP 500	1
9	F50492B3	BAR-RSA/1600	1
10	F30001A1	AXLE-800SS	1
11	F57260A9	BRG-STL FLG 1.01X1.05X.5	2
12	F50531A8	CLIP-SL/SH RH/400A	2
13	F30014A6	CLEVIS-BRK CABLE	1
14	F30012A8	LINK-CONN/825	2
15	Z30012A2	ECC-BRK SHORT	2
16	Z10069A6	PIN-SPG 3/16X5/8	1
17	Z10231A9	RING-RTNG 1/4	4
18	Z10030A2	NUT-HEX JAM 3/8-24	2
19	Z10602A2	WASHER-1/4 FLAT SAE	5
20	Z10013A3	BUSH-MACH 1x10GAx1-1/2 OD	2
21	Z50056A7	PLUG BOTTOM-1 1/8 ZP	2
22	Z10223A9	RING-RTNG 1	2
23	Z10209A7	WASHER-3/8 LOCK INT TOOTH	2
24	F50527A4	PIN-LOCK SL/SH/400	2
25	Z10113A2	S-HHC 1/4-20X1-1/4	1
26	Z10043A7	NUT-NYL NE 1/4-20	2
27	F50534A5	COLLAR-LONG (400)	2
28	Z10112A3	S-HHC 1/4-20X1	1
29	F50475A6	SPACER-A STD/C C/H	2
30	F50536A3	COLLAR SHT/400	2
31	Z10099A0	S-FHM 1/4-20x3/4	4
32	Z10035A7	NUT-HEX KEPS 1/4-20	8
33	Z10062A3	PIN-DOWEL 1/4X1 HARDENED	2
34	Z10805A2	BOLT-STRIPPER 1/4X1/2	1
35	Z10041A9	NUT-HEX MACH #10-32	1
36	Z10122A1	S-HHC 5/16-18X3/4	2
37	Z10066A9	PIN-SPG 1/8X7/8	4
38	Z10102A5	S-FHM 1/4-20x1-3/4	4
39	Z10025A9	NUT-HEX JAM 5/16-18	2
40	Z10208A8	WASHER-5/16 INT	2

PROPRIETARY AND CONFIDENTIAL
 THE INFORMATION CONTAINED IN THIS DRAWING IS THE SOLE PROPERTY OF VALLEY CRAFT. ANY REPRODUCTION IN PART OR AS A WHOLE WITHOUT THE WRITTEN PERMISSION OF VALLEY CRAFT IS PROHIBITED.

UNLESS OTHERWISE SPECIFIED:
 DECIMALS
 2 PLACES ±0.01
 3 PLACES ±0.005
 ANGLE ±1°
 GRIND/SAND SHARP EDGES .015 MAX
 DOES NOT APPLY TO DRILLED HOLE DIA.

VALLEYCRAFT
 2001 South Hwy. 61, Lake City, MN 55041-9555, U.S.A.
 TITLE: TRK-CYL/1620AA
 SIZE: PART NO. F86065A6
 B: MATL:
 SCALE: 1:16 WEIGHT: SHEET 2 OF 3

A	305266	DRAWN FROM CADKEY	TSH	4/23/2015
CHG	E.C.O.	DESCRIPTION / WAS	BY	DATE

ALL ANGLE ARE 90° UNLESS SPECIFIED

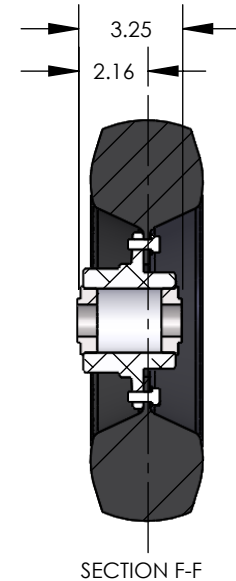
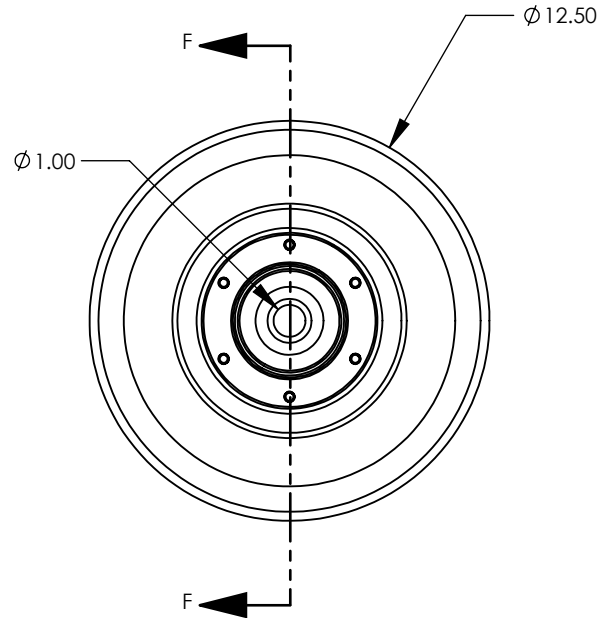
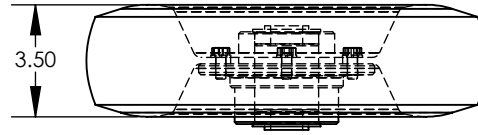
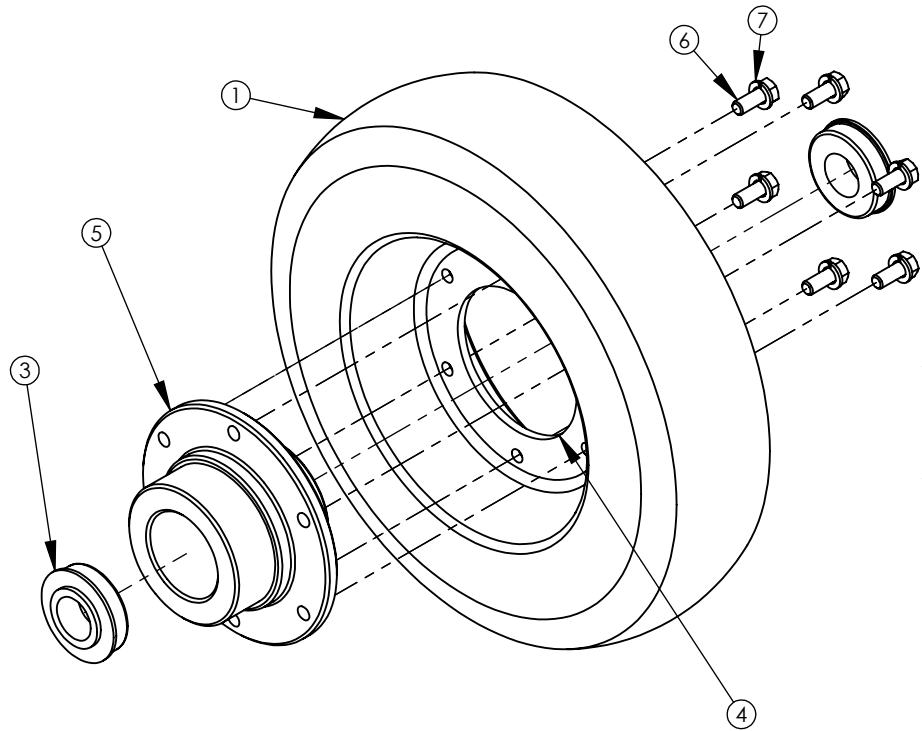

- 1. TIRE SIZE: 12.5 X 3.50
- 2. TREAD PATTERN: SAWTOOTH
- 3. WHEEL MATERIAL: RUBBER
- 4. LOAD CAP./WHEEL: 1535#
- 5. WEIGHT/WHEEL: 8#
- 6. OVERALL HUB WIDTH: 3.25
- 7. OFFSET CENTER OF
- 8. WHEEL TO END OF HUB: 2.16
- 9. HUB MATERIAL: ALUMINUM
- 10. BEARING TYPE: BALL
- 11. BORE OR AXLE SIZE: 1.00
- 12. HUB COLOR: SILVER
- 13. GREASE ZERK: NO
- 14. VENDOR: FASTENAL COMPANY

Item Number	Part Number	Description	Qty.
1	Z30007A9	TIRE-AIR 12	1
2	Z30008A8	TUBE-AIR 12	1
3	Z30002A4	BEARING-FLG 1/RPMT	2
4	Z30054A1/R70054	RIM-FEMALE AIR 12B -- CS use R70054 as RPMTS	1
5	Z30055A0/R70055	RIM-MALE AIR 12B -- CS use R70055 as RPMTS	1
6	Z10139A2	S-HHC 3/8-24X5/8	6
7	Z10214A0	WASHER-3/8 LOCK MD	6

PROPRIETARY AND CONFIDENTIAL
 THE INFORMATION CONTAINED IN THIS DRAWING IS THE SOLE PROPERTY OF VALLEY CRAFT. ANY REPRODUCTION IN PART OR AS A WHOLE WITHOUT THE WRITTEN PERMISSION OF VALLEY CRAFT IS PROHIBITED.

UNLESS OTHERWISE SPECIFIED:
 DECIMALS
 2 PLACES ±0.01
 3 PLACES ±0.005
 ANGLE ±1°
 GRIND/SAND SHARP EDGES .015 MAX
 DOES NOT APPLY TO DRILLED HOLE DIA.

VALLEYCRAFT®
 2001 South Hwy. 61, Lake City, MN 55041-9555, U.S.A.

TITLE: WHL-12 AIR BRK

A				10/31/2009
CHG.	E.C.O.	DESCRIPTION / WAS	BY	DATE

ALL ANGLES ARE 90° UNLESS SPECIFIED

	NAME	DATE
DRAWN		
CHECKED		
ENG APPR.		

SIZE	PART NO.
A	F60032A1
	MATL:
SCALE: 1:6	WEIGHT:
	SHEET 3 OF 3