

SOLUTIONS TO SIMPLIFY YOUR WORKLOAD
Drum Handling, Material Handling, Storage & Specialized Equipment

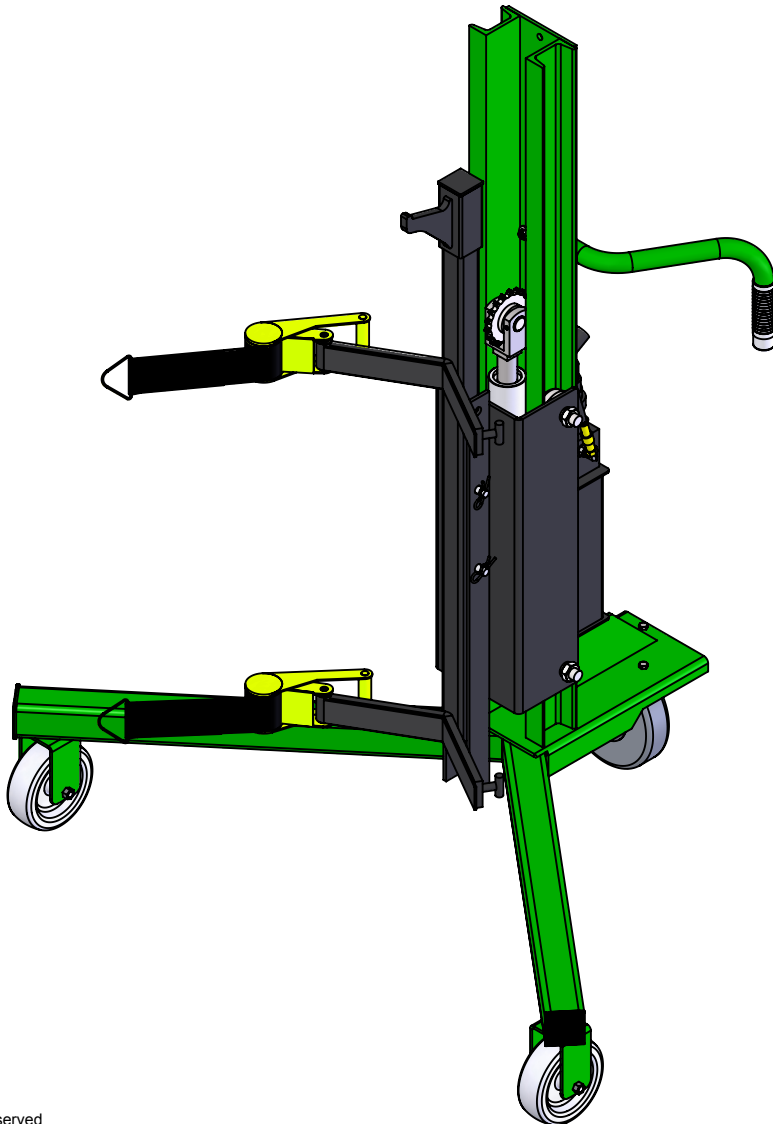

HARRIER-RATCHET STRAP F88576B4



Instruction Manual

HARRIER-RATCHET STRAP

Notice to Purchaser

All statements, technical information, and recommendations related to Valley Craft's products are based on information believed to be reliable, but the accuracy or completeness is not guaranteed. Before using this product, you must determine if it is suitable for your intended application or situation. You assume all risks and liability associated with such use or implementation.

Product Testing

We perform vigorous in-house safety and durability testing to ensure that the performance of our products meets the demands of the workplace. We also expect the same from manufacturers who supply components for our products. We do this to ensure that Valley Craft is a name that our customers trust and associate with quality.

Publication Revision Notice

Following is a history of changes to this publication, including the current revision.

Previously Updated: 03/11

Last Updated: 07/13

Copyright Notice

© Valley Craft, Inc. All rights reserved. No part of this publication may be reproduced, photocopied, stored on a retrieval system, or transmitted without the express written consent of Valley Craft.

Trademarks

The Valley Craft logo is a Valley Craft Trademark. All other company or product names are trademarks or registered trademarks of their respective owners. Use of a term in this document should not be regarded as affecting the validity of any trademark or service mark.

■ Table of Contents

Safety	4
• Safety Overview	4
• Safety Message Conventions.....	5
• Material Safety Data Sheets.....	6
Product Description	7
• Features	7
• Specifications	7
Unpacking and Assembly	7
• Receiving and Inspecting	7
Operation	8
• Operating Procedures	8
Maintenance and Adjustments	9,10
• Maintenance and Adjustment Procedures.....	9,10
Troubleshooting	11
• Troubleshooting Procedures	11
Replacement	11
• Replacement Procedures.....	11
Parts List	12,13
• Isometric View	12
• Parts List	13
• Ordering Information	12

Safety

Read and understand all safety information and become familiar with all safety symbols contained in this section before moving, operating or performing maintenance on this equipment.

■ Safety Overview

The following general safety precautions must be observed during all phases of operation, service, and repair of this equipment. Failure to comply with these precautions or with specific safety messages elsewhere in this manual may impair the protection provided by the equipment. Such noncompliance would also violate safety standards of design, manufacture, and intended use of the instrument.

- Observe all safety signs posted in your facility.
- Observe warnings, cautions, handling information, storage requirements and other information on all container labels.
- Wear safety glasses with side shields.
- Wear the proper protective clothing, gloves and other protective equipment before handling any chemicals.
- Group the containers for the move by Hazard Class. Do not move acids with toxics, or oxidizers.
- Use maximum care and good judgment in preventing accidents and injuries and seeking first aid.
- Report unsafe conditions, equipment, practices, and on-job injuries.
- Understand your supervisor's instructions. Ask questions if you do not know how to do the job safely.
- Do not engage in tasks which you believe might be unsafe without consulting your supervisor.
- Clean up the work area and equipment upon job completion.
- Before you start work on any electrical system or circuit, check all power sources to ensure that the system or circuit is de-energized.
- Know the hazardous or potentially hazardous substances you work with or are present in your work area. Review Material Safety Data Sheets (MSDS) on these substances, or contact your supervisor.

■ Safety Message Conventions

There are three types of safety notices contained in this manual: **Danger**, **Warning**, and **Caution** notices. These notices precede the procedural step or portion of text that presents the safety hazard.



DANGER

- **DANGER** indicates an imminently hazardous situation which, if not avoided, will result in death or serious injury. This signal word is to be limited to the most extreme situations.
-



WARNING

- **WARNING** indicates a potentially hazardous situation which, if not avoided, could result in death or serious injury.
-



CAUTION

- **CAUTION** indicates a potentially hazardous situation which, if not avoided, may result in minor or moderate injury. It may also be used to alert against unsafe practices
-

HARRIER-RATCHET STRAP

■ Material Safety Data Sheets (MSDS)

A Material Safety Data Sheet (MSDS) provides information on the safe use, handling and potential hazards of a product. This information assists with the proper response in the event of an emergency.

Valley Craft maintains material safety data sheets (MSDSs) on all our products. You are urged to obtain copies of the relevant MSDSs before using our products to protect yourself and others against any known health or safety hazards described in these MSDSs. Valley Craft strives to make safety a top priority. Do not hesitate to contact us to discuss any safety aspects of our products.

The relevant MSDS codes for Valley Craft products are listed below.

- www.conocophillips.com
Super ATF Transmission Oil, MSDS Code 778846
Super-Sta Grease, MSDS Code 775440
- www.batteriesplus.com
Sealed Lead Acid Battery
SLA for the English version
SLA Sp for the Spanish version
- [Paint](#)
Contact Valley Craft Customer Service at 1-800-328-1480 or on the Web at customer@valleycraft.com

■ Additional Safety Information

As with any mechanical device, care must be taken during the installation, operation, and maintenance of the device in order to realize the maximum benefit from its ownership.

When raising and lowering the load, be aware of pinch points. Keep hands and feet away from these areas.

When transporting a load, it is recommended that the cylinder is lowered as close to the floor as possible to reduce the chances of accidents during transport.

Do not leave load suspended for an extended period of time or premature wear to the lifting cylinder may occur.

Activate safety brake on the swivel caster when Harrier is not in use.

Note: All personnel involved in the use and maintenance of this device should be thoroughly familiar with the information contained in this manual. Furthermore, it is recommended that all personnel be given adequate instruction and a sufficient period of training in its actual use to insure safety of personnel and proper care of the equipment. It is suggested that the unit be initially operated empty until becoming familiar with how the unit handles.

Product Description

The Harrier has been engineered for easy access and maneuverability. The simple design safely secures and transports gas and cryogenic cylinders with ease. It allows the operator to safely manipulate a variety of cylinder types and sizes 9in. to 24in. diameter, up to 800#, while reducing injury to the operator.

■ Specifications

The Harrier specifications are shown in Table 1.

Table 1. Specifications

Dimensions	Height 62in x Width 50" x Depth 40"
Weight	231 lbs
Load Capacity	800 lbs
Cylinder Lift	Hand operated heavy duty hydraulic pump
Cylinder Grab	Cylinder Hook Two ratchet strap assemblies
Hydraulic Fluid Capacity	48 Ounces
Wheels	Rear swivel 8 x 2 phenolic caster with brake Front two 6 x 2 phenolic casters

■ Features

The Harrier offers state-of-the-art design with many advanced features.

- Hand operated heavy duty hydraulic pump to raise and lower the drum
- Hands Free cylinder hook and ratchet straps
- V-leg design makes it an efficient way of handling cylinders on and around pallets.
- The small foot print is ideal for negotiating narrow aisles and doorways.
- Rear swivel phenolic caster with brake and two front fixed phenolic wheels allows the operator to move cylinders easily

■ Receiving and Inspecting

When unpacking the Harrier, inspect the equipment for damage or mishandling. If damage is noted, file a damage claim with the carrier within 24 hours and call Valley Craft at 1-800-328-1480. Do not attempt to use the equipment.

Compare the contents of the shipment with the bill of lading. Report any missing items to the carrier and to Valley Craft immediately.

HARRIER-RATCHET STRAP

■ Operating Procedures

Only authorized personnel are permitted to use the Harrier. Every load and every situation is different. Every lift must be evaluated and planned. Observe the following procedures when using this equipment.

- To **RAISE** the Ratchet Assemblies:

Position the lever on top of the hydraulic pump in the left horizontal position, move the pump handle up and down.

- To **LOWER** the Ratchet Assemblies:

The speed of decent can be regulated by rotating the lever on top of the hydraulic pump from the left horizontal position to the right horizontal position . To stop lowering, move the lever back to the left horizontal position.

- To **Handle Gas Cylinders:**

A. Turn cylinder hook sideways (perpendicular) to the cylinder cradle. Cylinder Hook is not used with gas cylinders.

B. Raise/Lower cylinder cradle to a position that is centered on the cylinder.

B. Move the Harrier forward until the cylinder cradle comes in contact with the cylinder.

C. Wrap the nylon straps of the ratchet assemblies around the cylinder, hook onto the welded “T”, and ratchet straps until tight.

D. Raise the cylinder and transport as needed.

E. Release the cylinder by setting to the floor, depressing the release on the ratchet assembly and unhooking the strap from the welded “T”.

- To **Handle Cryogenic Cylinders:**

A. Turn cylinder hook facing forward at the top of the cylinder cradle.

B. Raise/Lower the cylinder cradle in order to engage the “eye-hole” near the top of the cylinder.

C. Move the Harrier forward until the cylinder cradle comes in contact with the cylinder

D. Raise the cylinder and transport as needed.

E. **NOTE:** The ratchet assemblies do not need to be used, but are recommended when transporting over long distances or over rough surfaces. See above steps for ratchet instructions.

HARRIER-RATCHET STRAP

■ Maintenance and Adjustment Procedures

To keep the Harrier operating properly, timely maintenance and adjustments are required. These procedures should be performed only by qualified personnel who are familiar with the equipment.

As with any mechanical hydraulic actuator (piston rods, rotating pump shaft, etc.) the shaft will become coated with a minute amount of oil from the internal high pressure system. The rod protruding from the cylinder and hand pump may feel damp with oil after use. This is desirable because the oil coating serves to lubricate the shaft seal, reducing friction and assuring extended seal life.

Maintenance and adjustment procedures are shown in Table 1.

Table 1. Maintenance and Adjustment Procedures

Component	Frequency	Operation	Procedure
Cylinder	As required	Leaking hydraulic fluid	Replace seal. Order Z20768A5 Seal Kit See Sheet # 11
Hand Pump	As required	Leaking hydraulic fluid	Replace seal. Order Z20519A7 Seal Kit See Sheet # 11
Chain	As required	Lubricate	Oil Chain
Hydraulic Fluid	Every 40 hours or after long set-aside periods	Check Fluid	Make sure cylinder is fully retracted. Fill Reservoir to within 1 in. to 2 in. of the fill hole. Use Super ATF Transmission Fluid. *NOTE: To fill/change reservoir, remove pump pod that sits on top of reservoir. See Sheet # 10
	Yearly	Flush hydraulic system	Drain all hydraulic fluid and replace with 48 ounces of Super ATF Transmission Fluid. Make sure cylinder is fully retracted.
Ratchet Assembly	As required	Check nylon straps for wear	Replace as necessary

HARRIER-RATCHET STRAP

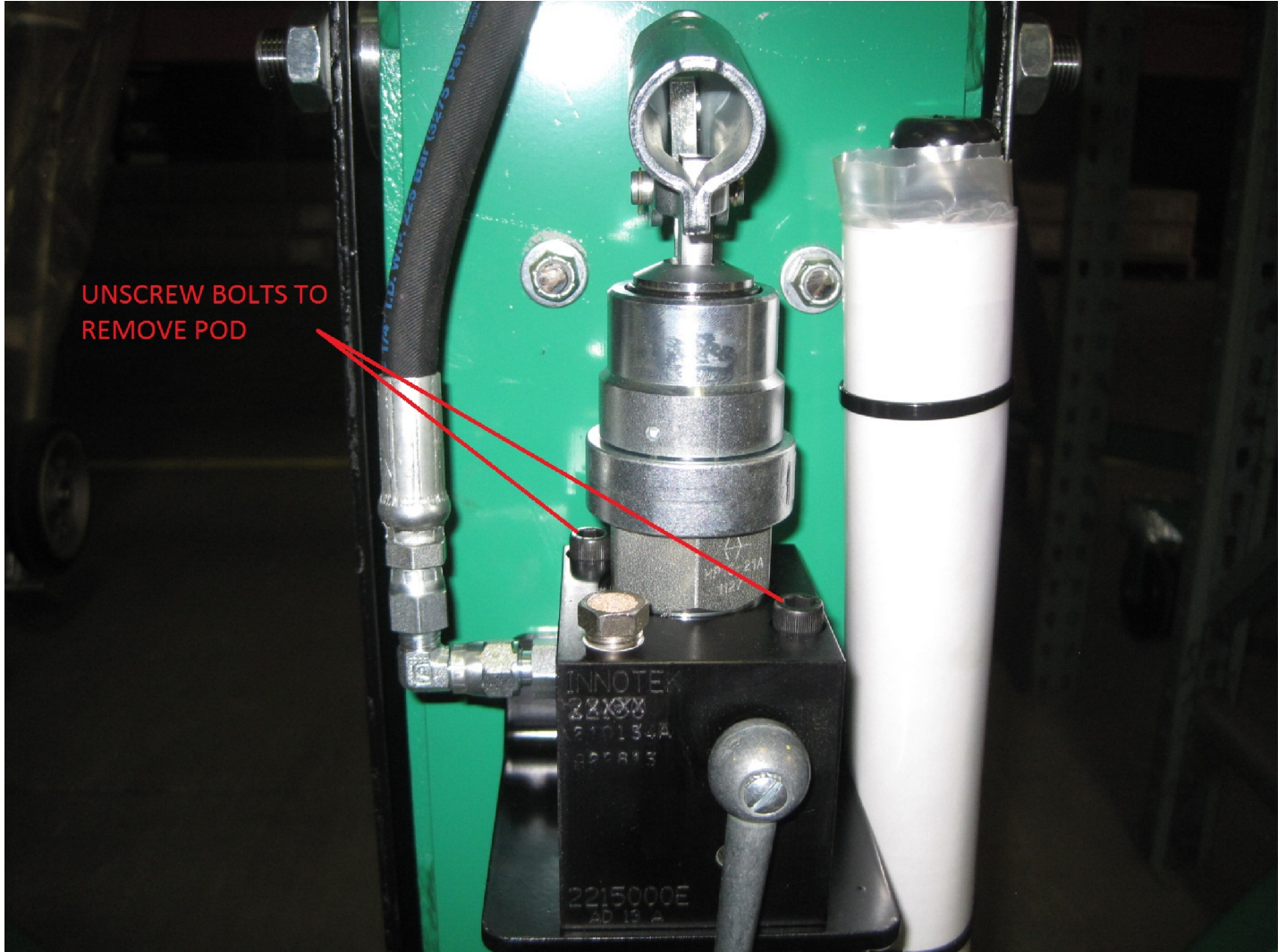

■ **Troubleshooting Procedures**

The Harrier is a quality product that is designed and manufactured to provide prolonged service under normal operating conditions. If troubleshooting is required, it should be performed only by qualified personnel who are familiar with the equipment.

■ **Replacement Procedures**

Occasionally, it may be necessary to replace a part that has been damaged or worn. Many parts on the Harrier are replaceable. If replacement of a part is required, it should be performed only by qualified personnel who are familiar with the equipment.

See sheet 12 for available replacement parts. Identify the part number you need. Contact Valley Craft Customer Service at 1-800-328-1480 or on the web at customer@valleycraft.com.

Information required when contacting Valley Craft:

- A. Company name and address
- B. Contact persons name
- C. Telephone number
- D. E-Mail address
- E. Model Number
- F. Date of Manufacture
- G. Part number of parts ordering

The model number and date of manufacture is stamped on a metal tag located on the frame above the push handle.

HARRIER-RATCHET STRAP

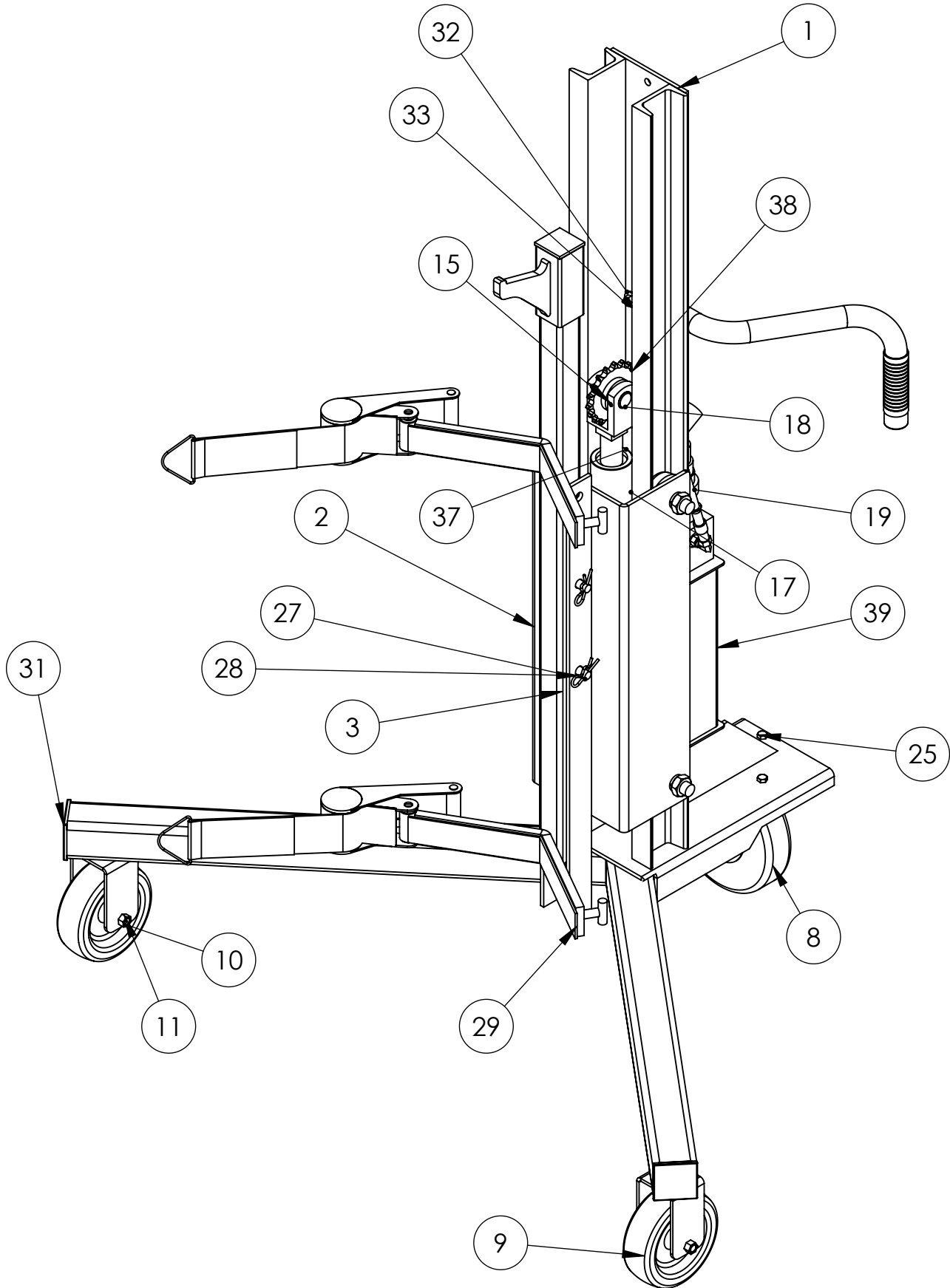

HARRIER-RATCHET STRAP

BOM Table			
ITEM NO.	PART NUMBER	DESCRIPTION	Default/QTY.
1	F64985A5	RAPTOR WLDMNT-MAST	1
2	F64984A6	HARRIER ASSY-ATTMT	1
3	F64499A3	HARRIER RS ATTMT	1
4	F64498A4	HARRIER HOOK WLDMT-ATTMT	1
5	F62980A9	RATCHET ASSY-2.0X53.00 7000	2
6	Z40469A9	DECAL-LOAD CAP 800	1
7	Z40457A3	DECAL-CAUTION STRADDLE LIFT	1
8	Z30538A8	CSTR-8X2 SWL PHN TLB	1
9	Z30552A4	WHL-6 x 2 PNH	2
10	Z10585A9	S-HHC 1/2-13X3-1/4	2
11	Z10393A3	NUT-LOCK 1/2-13	2
12	Z10113A2	S-HHC 1/4-20X1-1/4	2
13	Z10043A7	NUT-NYL NE 1/4-20	2
14	Z20734A0	BREATHER 4 SAE SINTERED	1
15	Z10072A1	PIN-SPG 1/4X1-1/2	1
16	Z20615A7	FTG STR 6400-4-4-O	1
17	Z10241A7	BOLT-U 5/16-18 X 2-1/2	1
18	F52067A6	PIN-CLEVIS 1.00X2.375	1
19	Z20736A8	HOSE-20.00/613	1
20	Z10045A5	NUT-NYL NE 5/16-18	2
21	Z10200A6	WASHER-1/4 FLAT USS	8
22	Z10186A4	S-SHC 1/4-20X1/2 GR8	1
23	Z10035A7	NUT-HEX KEPS 1/4-20	4
24	Z10020A4	NUT-HEX FULL 1/2-13	2
25	Z10123A0	S-HHC 5/16-18X1	2
26	Z10036A6	NUT-HEX KEPS 5/16-18	2
27	Z30573A3	PIN-CLEVIS 1/2 X 3	2
28	Z10064A1	PIN-HITCH CLIP #16 1/8 X 1.44	2
29	Z50037A1	RUBBER PAD-1/8 X 1-3/4 ADH	2
30	Z10525A3	BUSH-SPAN 3/4X1/2x2-7/16	2
31	Z30083A6	CAPLUG 2-1/2 SQ X 1.1GA	2
32	Z10006A2	WASHER-3/8 FNDR	2
33	Z10047A3	NUT-NYL NE 3/8-16	2
34	F58821A4	PIPE-0.84XSCH 40X16.00 GALV	1
35	Z50051A2	GRIP-HDL 1/2" PIPE BLACK	1
36	Z50085A2	GRIP-HDL 1-1/4" BLK	2
37	Z20755A8	CYL ASSY/RAPTOR	1
38	F63091A3	SPROCKET ASSY-50C18 BRG 1.01	1
39	Z20852A9	PUMP-HYD HAND LEVER	1
40	Z20704A0	FTG 90 6500-4-4 SWL	1
41	Z10122A1	S-HHC 5/16-18X3/4	4
42	Z10213A1	WASHER-5/16 LOCK MD	4
43	Z41156A5	LABEL-VALLEYCRAFT PAPER	1
44	Z40473A3	TAG/SERIAL NO	1
45	F63858RB	CHAIN-RLR ASSY LONG	1

NOTE:
SEE SHEET NUMBER 9 FOR CYLINDER AND
HAND PUMP SEAL KITS.

Warranty and Limitation of Liability

Valley Craft products are warranted for a period of one (1) year from date of shipment from Valley Craft's plant to be free from defects in material and workmanship under correct use, normal operation and proper application. However, parts of other than Valley Craft manufacture are subject ONLY to the original manufacturer's warranty. Valley Craft's obligation under warranty shall be limited to repair or exchange, at Valley Craft's option, FOB origin factory, of any Valley Craft product or part which proves to be defective as provided herein. Valley Craft reserves the right to either inspect the product at Buyer's location, or require it to be returned to the factory for inspection. The warranty contained herein does not extend to goods damaged, or subject to accident, abuse or misuse after shipment from Valley Craft's factory, nor to goods altered or repaired by anyone other than an authorized Valley Craft representative.

Buyer or user shall not alter, modify or use a Valley Craft product for anything other than its intended function. Valley Craft shall not in any way be responsible for the consequences of any such alteration, modification or misuse.

VALLEY CRAFT MAKES NO EXPRESS WARRANTIES OTHER THAN THOSE WHICH ARE SPECIFICALLY DESCRIBED HEREIN. Any description of the goods sold hereunder, including any references to Buyer's specifications and any descriptions in catalogs, circulars and other written material published by Valley Craft, is for the sole purpose of identifying such goods and shall not create an express warranty that the goods shall conform to such descriptions.

THIS WARRANTY IS EXPRESSLY IN LIEU OF ALL OTHER WARRANTIES, EXPRESS OR IMPLIED. THERE ARE NO IMPLIED WARRANTIES OF MERCHANTABILITY OR FITNESS FOR A PARTICULAR PURPOSE. THIS WARRANTY STATES VALLEY CRAFT'S ENTIRE AND EXCLUSIVE LIABILITY AND BUYER'S EXCLUSIVE REMEDY FOR ANY CLAIM OR DAMAGES IN CONNECTION WITH VALLEY CRAFT PRODUCTS, THEIR DESIGN, SUITABILITY FOR USE, INSTALLATION OR OPERATION OR FOR ANY CLAIMED DEFECTS. VALLEY CRAFT WILL IN NO EVENT BE LIABLE FOR INCIDENTAL OR CONSEQUENTIAL DAMAGES WHATSOEVER, NOR FOR ANY SUM IN EXCESS OF THE PRICE RECEIVED FOR THE GOODS FOR WHICH LIABILITY IS CLAIMED.

Technical Assistance/Warranty Procedure

What's Covered:

- Parts and Labor to correct manufacturer's defect within one year of purchase.
- Freight Cost

What's Not:

- Normal wear items (seal kits, bearings, tires, etc.)

What Voids the Warranty:

- Dirt/Grime that directly causes malfunction of product
 - Abuse (i.e. Overloading, damaged, not properly maintained, etc.)
 - Product altered by customer
- *See "Items not Under Warranty" below for items that have the warranty voided.

Items Under Warranty (less than one year old):

- Warranty replacement parts are provided only when the problem can be identified with near certainty. If not, the customer will return item to Valley Craft, freight collect, for troubleshooting and/or repair. When repaired, product will be returned to customer,



Valley Craft is a modern metals fabricating manufacturer specializing in material handling, storage and specialized solutions designed with safety and usability in mind, and the simplification of even the heaviest of workloads. Since developing the first hand truck with a brake in 1952, Valley Craft has been a true pioneer in safety-conscious material handling and solution-driven products. Our commitment to continuous improvement in a Lean Manufacturing environment results in safe, functional, quality equipment at affordable prices.

Valley Craft, Inc.

2001 South Highway 61
Lake City, Minnesota 55041 U.S.A.

Phone: (651) 345-3386

Toll Free: (800) 328-1480

Fax: (651) 345-3606

E-Mail: customer@valleycraft.com

Web: valleycraft.com • ovation-solutions.com
