

**SOLUTIONS TO SIMPLIFY YOUR WORKLOAD**  
Drum Handling, Material Handling, Storage & Specialized Equipment

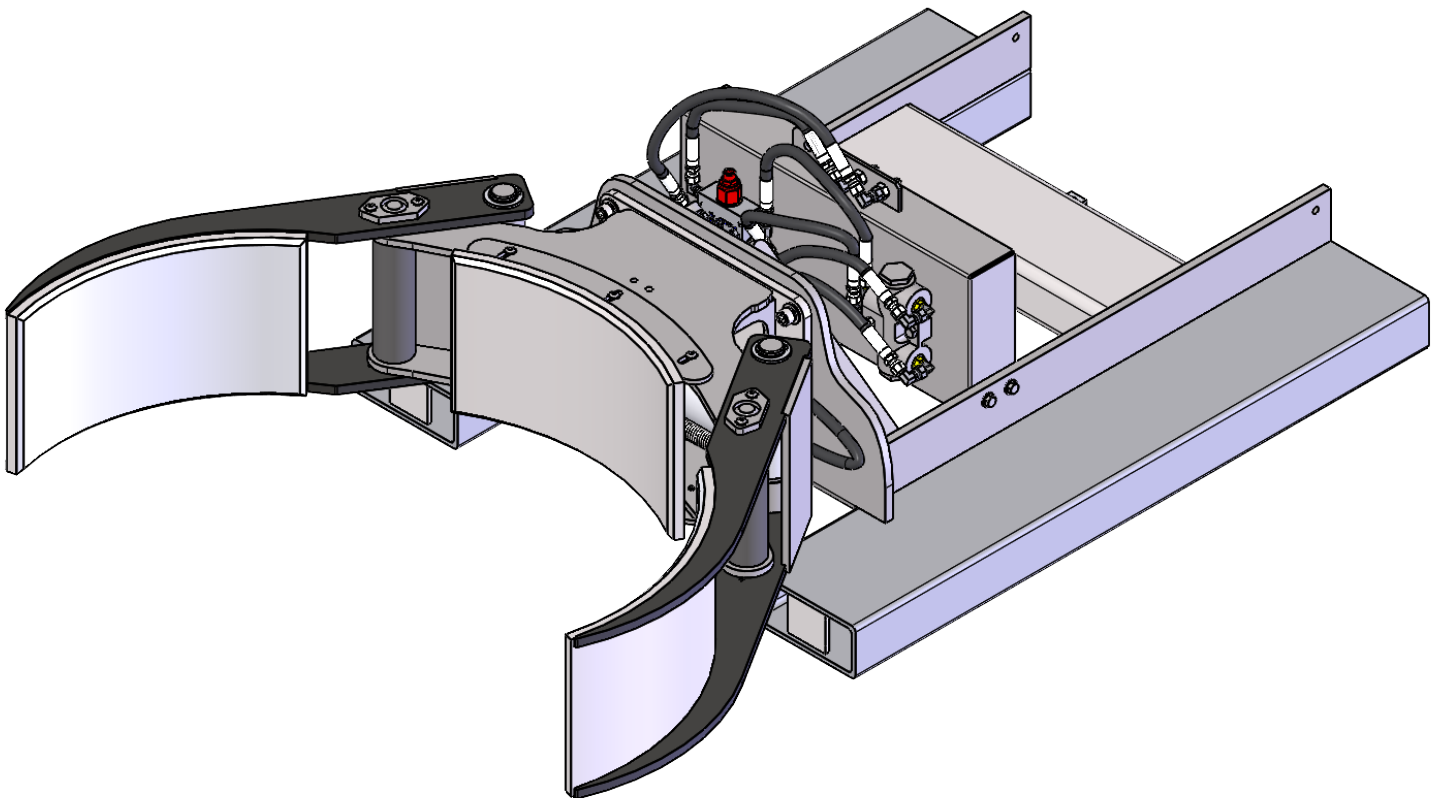

## **MAXI II-2K# LT, CLAMP ONLY F89704**



## **Notice to Purchaser**

All statements, technical information, and recommendations related to Valley Craft's products are based on information believed to be reliable, but the accuracy or completeness is not guaranteed. Before using this product, you must determine if it is suitable for your intended application or situation. You assume all risks and liability associated with such use or implementation.

## **Product Testing**

We perform vigorous in-house safety and durability testing to ensure that the performance of our products meets the demands of the workplace. We also expect the same from manufacturers who supply components for our products. We do this to ensure that Valley Craft is a name that our customers trust and associate with quality.

## **Publication Revision Notice**

Following is a history of changes to this publication, including the current revision.

Previous Revisions: Z41271A8 REV B (12/15)

Current Revision: Z41271A8 REV C (7/21)

## **Copyright Notice**

© Valley Craft, Inc. All rights reserved. No part of this publication may be reproduced, photocopied, stored on a retrieval system, or transmitted without the express written consent of Valley Craft.

## **Trademarks**

The Valley Craft logo is a Valley Craft Trademark. All other company or product names are trademarks or registered trademarks of their respective owners. Use of a term in this document should not be regarded as affecting the validity of any trademark or service mark.

## ■ Table of Contents

---

|  |              |
|--|--------------|
| <b>Safety</b> .....                                  | <b>4-6</b>   |
| Safety Overview .....                                | 4            |
| Safety Message Conventions .....                     | 5            |
| Safety Data Sheets .....                             | 6            |
| <b>Product Description</b> .....                     | <b>7</b>     |
| Specifications .....                                 | 7            |
| Features .....                                       | 7            |
| <b>Unpacking and Assembly</b> .....                  | <b>8</b>     |
| Receiving and Inspection .....                       | 8            |
| <b>Operation</b> .....                               | <b>9-10</b>  |
| Operating Procedure Pressure Relief Adjustment ..... | 9            |
| Operating Procedure Safety .....                     | 10           |
| <b>Maintenance and Adjustments</b> .....             | <b>11</b>    |
| Maintenance and Adjustment Procedures .....          | 11           |
| <b>Troubleshooting</b> .....                         | <b>12</b>    |
| Trouble Shooting Procedures .....                    | 12           |
| <b>Replacement</b> .....                             | <b>13</b>    |
| Replacement Procedures .....                         | 13           |
| <b>Parts List</b> .....                              | <b>14-17</b> |
| Exploded View and BOM UGIII .....                    | 14           |
| Exploded View Jaw Assy .....                         | 15           |
| BOM Jaw Assy .....                                   | 16           |
| Exploded View and BOM Valve Assy .....               | 17           |
| <b>Equipment Drawings</b> .....                      | <b>18-19</b> |
| Hydraulic Schematic .....                            | 18           |
| Lost Load Info .....                                 | 19           |

## Safety

*Read and understand all safety information and become familiar with all safety symbols contained in this section before moving, operating or performing maintenance on this equipment.*

### ■ Safety Overview

The following general safety precautions must be observed during all phases of operation, service, and repair of this equipment. Failure to comply with these precautions or with specific safety messages elsewhere in this manual may impair the protection provided by the equipment. Such noncompliance would also violate safety standards of design, manufacture, and intended use of the instrument.

- Observe all safety signs posted in your facility.
- Observe warnings, cautions, handling information, storage requirements and other information on all container labels.
- Wear safety glasses with side shields.
- Wear the proper protective clothing, gloves and other protective equipment before handling any chemicals.
- Group the containers for the move by Hazard Class. Do not move acids with toxics, or oxidizers.
- Use maximum care and good judgment in preventing accidents and injuries and seeking first aid.
- Report unsafe conditions, equipment, practices, and on-job injuries.
- Understand your supervisor's instructions. Ask questions if you do not know how to do the job safely.
- Do not engage in tasks which you believe might be unsafe without consulting your supervisor.
- Clean up the work area and equipment upon job completion.
- Before you start work on any electrical system or circuit, check all power sources to ensure that the system or circuit is de-energized.
- Know the hazardous or potentially hazardous substances you work with or are present in your work area. Review Safety Data Sheets (SDS) on these substances, or contact your supervisor.
- **Please review more detailed safety information on page 13.**

## ■ **Safety Message Conventions**

Three types of safety notices may be contained in this manual: **Danger**, **Warning** and **Caution** notices. These notices precede the procedural step or portion of text that presents the safety hazard.



### **DANGER**

---

- **DANGER** indicates an imminently hazardous situation which, if not avoided, will result in death or serious injury. This signal word is to be limited to the most extreme situations.
- 



### **WARNING**

---

- **WARNING** indicates a potentially hazardous situation which, if not avoided, could result in death or serious injury.
- 



### **CAUTION**

---

- **CAUTION** indicates a potentially hazardous situation which, if not avoided, may result in minor or moderate injury. It may also be used to alert against unsafe practices
-

## ■ Material Safety Data Sheets (MSDS)

A Safety Data Sheet (SDS) provides information on the safe use, handling and potential hazards of a product. This information assists with the proper response in the event of an emergency.

Valley Craft maintains safety data sheets (SDSs) on all our products. You are urged to obtain copies of the relevant SDSs before using our products to protect yourself and others against any known health or safety hazards described in these SDSs. Valley Craft strives to make safety a top priority. Do not hesitate to contact us to discuss any safety aspects of our products.

**The relevant SDS codes for Valley Craft products are listed below.**

- [www.conocophillips.com](http://www.conocophillips.com)  
Super ATF Transmission Oil, MSDS Code 778846  
Super-Sta Grease, MSDS Code 775440
- [www.batteriesplus.com](http://www.batteriesplus.com)  
Sealed Lead Acid Battery  
SLA for English version  
SLA Sp for the Spanish version
- [Paint](#)  
Contact Valley Craft Customer Service at 1-800-328-1480 or on the Web at [customerservice@valleycraft.com](mailto:customerservice@valleycraft.com)

## ■ Additional Safety Information

As with any mechanical device, care must be taken during the installation, operation, and maintenance of the device in order to realize the maximum benefit from its ownership.

**Note:** All personnel involved in the use and maintenance of this device should be thoroughly familiar with the information contained in this manual. Furthermore, it is recommended that all personnel be given adequate instruction and a sufficient period of training in its actual use to insure safety of personnel and proper care of the equipment. It is suggested that the units be initially operated empty until becoming familiar with operation of this unit.

## MAXI II-2K# LT, CLAMP ONLY

### Product Description

The Maxi II is a lift truck-powered lift truck attachment which allows the operator to clamp drums from most lift trucks without any additional equipment.

### ■ Specifications

The Maxi II specifications are shown in Table 1.

*Table 1. Specifications*

|                      |                       |
|----------------------|-----------------------|
| <b>Dimensions</b>    | <b>34"Wx60"Lx16"H</b> |
| <b>Weight</b>        | <b>425 lbs</b>        |
| <b>Load Capacity</b> | <b>2000 lbs</b>       |

### ■ Features

The Maxi II offers state-of-the-art design with many advanced features.

- Pressure reducing valve to control clamp pressure
- Clamping system that clamps steel, fiber, and plastic drums

## ■ Receiving and Inspecting

When unpacking the Maxi II, inspect the equipment for damage or mishandling. If damage is noted, file a damage claim with the carrier within 24 hours and call Valley Craft at 1-800-328-1480. Do not attempt to use the equipment.

Compare the contents of the shipment with the bill of lading. Report any missing items to the carrier and to Valley Craft immediately.

## ■ Operating Procedures

Only authorized personnel are permitted to use the Maxi II. Every load and every situation is different. Every load must be evaluated and planned. Observe the following procedures when using this equipment.

All personnel should be given adequate instruction and a sufficient period of training in actual use of the attachment to insure safety and proper care. The Maxi II is intended for use with sealed containers.

**(Please note:** There is a spacer block located inside the end of each fork tube. The purpose of these spacers is to provide a tighter fit for standard thickness forks. For forks that are too thick to fit, the spacers can be knocked out and removed.)

1. Insert forks of lift truck into fork tube of drum grip.
2. Attach safety chain to clevis on rear of frame and wrap chain around forklift carriage and clip the safety hook.
3. Attach hydraulic quick couplers on 48" long hoses to those on lift truck auxiliary control valve.
4. Advance lift truck until jaws of drum grip center around the drum.
5. Grip drum in center at all times.
6. Activate clamping pressure with auxiliary control valve on the lift truck.
7. If drum grip needs to be removed from forklift, set unit down, remove safety chain from around carriage, unhook hydraulic quick couplers, and back away from the drum grip.



# MAXI II-2K# LT, CLAMP ONLY

## ■ Operating Procedures for Pressure Relief Adjustment for Clamp Function

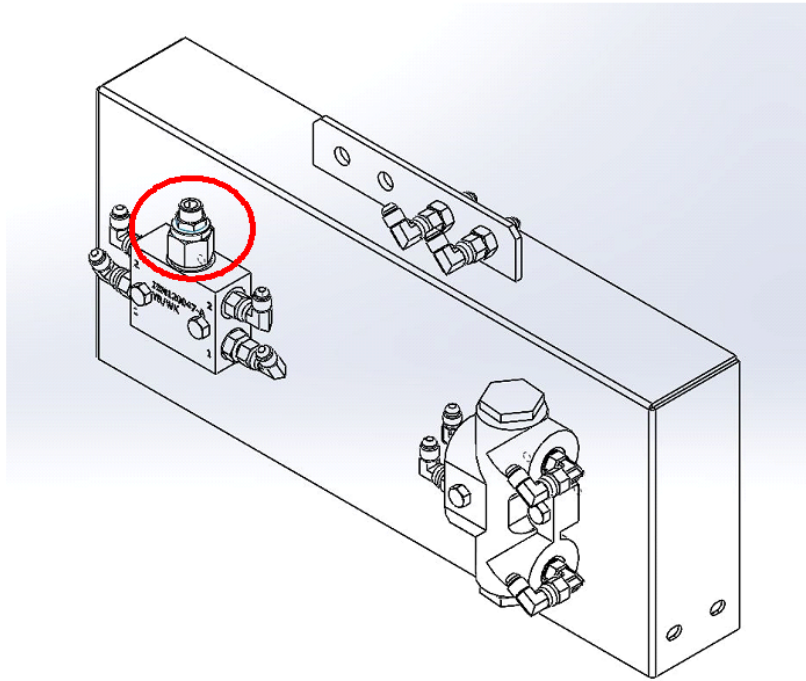

### Adjusting Pressure Relief

The pressure relief valve is found on the valve pan. Once the valve has been located adjustments can be made by loosening the jam nut. Adjusting the valve CW (clock wise) increase pressure while adjusting the valve CCW (counter clock wise) decrease the pressure. Each fork truck comes with different system pressure and this valve allows for adjustment.

Each load requires different pressure setting dependant on the items listed below

1. Barrel Material (steel, plastic, fiber)
2. Weight of barrel
3. Rigidity of barrel (open or closed)

Valley Craft has done testing on different loads and offer some guidelines below.

| Barrel Material | Weight of barrel | Rigidity of barrel | Pressure Setting PSI |
|-----------------|------------------|--------------------|----------------------|
| Steel           | 2000             | Closed             | 1400                 |
| Plastic         | 800              | Closed             | 1000                 |
| Fiber           | 500              | Closed             | 1000                 |

The Maxi II comes standard with the clamp pressure set at 1200 psi, each end user should verify this is the correct setting for their load.

### Troubleshooting

| Problem       | Possible Causes   |
|---------------|---|
| Drum Slipping | Pressure to low<br>Drum not against back jaw saddle when clamping |
| Drum Crushing | Pressure to high  |
|               |   |
|               |   |

## Safety

*Read and understand all safety information and become familiar with all safety symbols contained in this section before moving, operating or performing maintenance on this equipment.*



### **CAUTION**

---

- It is recommended that all operators practice operation of the Maxi II and its controls with an empty drum before using it on full drums to familiarize themselves with the machine and to develop safe working habits.
- Too much pressure applied to the drum will cause crushing.
- Never activate the clamping function while the forklift is in motion.
- Maximum lifting capacity is 2000 lbs. Actual capacity may be limited by the size of the lift truck. Always follow lift truck manufacturer's specifications.

## Maintenance and Adjustments

### ■ Maintenance and Adjustment Procedures

To keep the Maxi II operating properly, timely maintenance and adjustments are required. These procedures should be performed only by qualified personnel who are familiar with the equipment.

#### **Important:**

- **Always disconnect quick couplers from the fork truck before beginning an inspection or repair.**

#### **Before each use:**

1. Inspect safety chain and verify it is in good condition. Replace if necessary.
2. Inspect attachment for sharp edges or burrs.
3. Inspect hydraulic hoses for any leaks or punctures.

#### **Every 6 months:**

1. Inspect and grease pivot points.
2. Inspect all fasteners and tighten if necessary.

## Troubleshooting

### ■ Troubleshooting Procedures

The Maxi II is a quality product that is designed and manufactured to provide prolonged service under normal operating conditions. If troubleshooting is required, it should be performed only by qualified personnel who are familiar with the equipment.

| <b>Problem</b>  | <b>Possible Cause</b>     | <b>Solution</b>  |
|---|---------------------------|--|
| Difficult to attach quick couplers to auxiliary valve | Built up pressure         | Shut off forklift and work auxiliary valve back and forth a few times to release pressure                    |
| Unit is crushing drums                                | Too much pressure applied | Grip drum just to the point that the drum starts to distort.<br><br>Adjust pressure valve on fork attachment |
| Cylinder leaking                                      | Worn/old o-rings          | Replace seals in cylinder  |

## Replacement

### ■ Replacement Procedures

Occasionally, it will be necessary to replace a part that has been damaged or worn. Many parts on this Ultra Grip are replaceable. If replacement of a part is required, it should be performed only by qualified personnel who are familiar with the equipment.

See page 17 for available replacement parts. Identify the part number you need. Contact Valley Craft Customer Service at 1-800-328-1480 or on the Web at [customerservice@valleycraft.com](mailto:customerservice@valleycraft.com).

Information required when contacting Valley Craft:

- A. Company name and address
- B. Contact persons name
- C. Telephone number
- D. E-Mail address
- E. Model Number
- F. Date of manufacture
- G. Part number(s) of part(s) to be ordered

The model number and date of manufacture is stamped on a metal tag located on the control box.

MAXI II-2K# LT, CLAMP ONLY

F89704 MAXI II-2K# STD LT  
ISO View and Bill of Materials

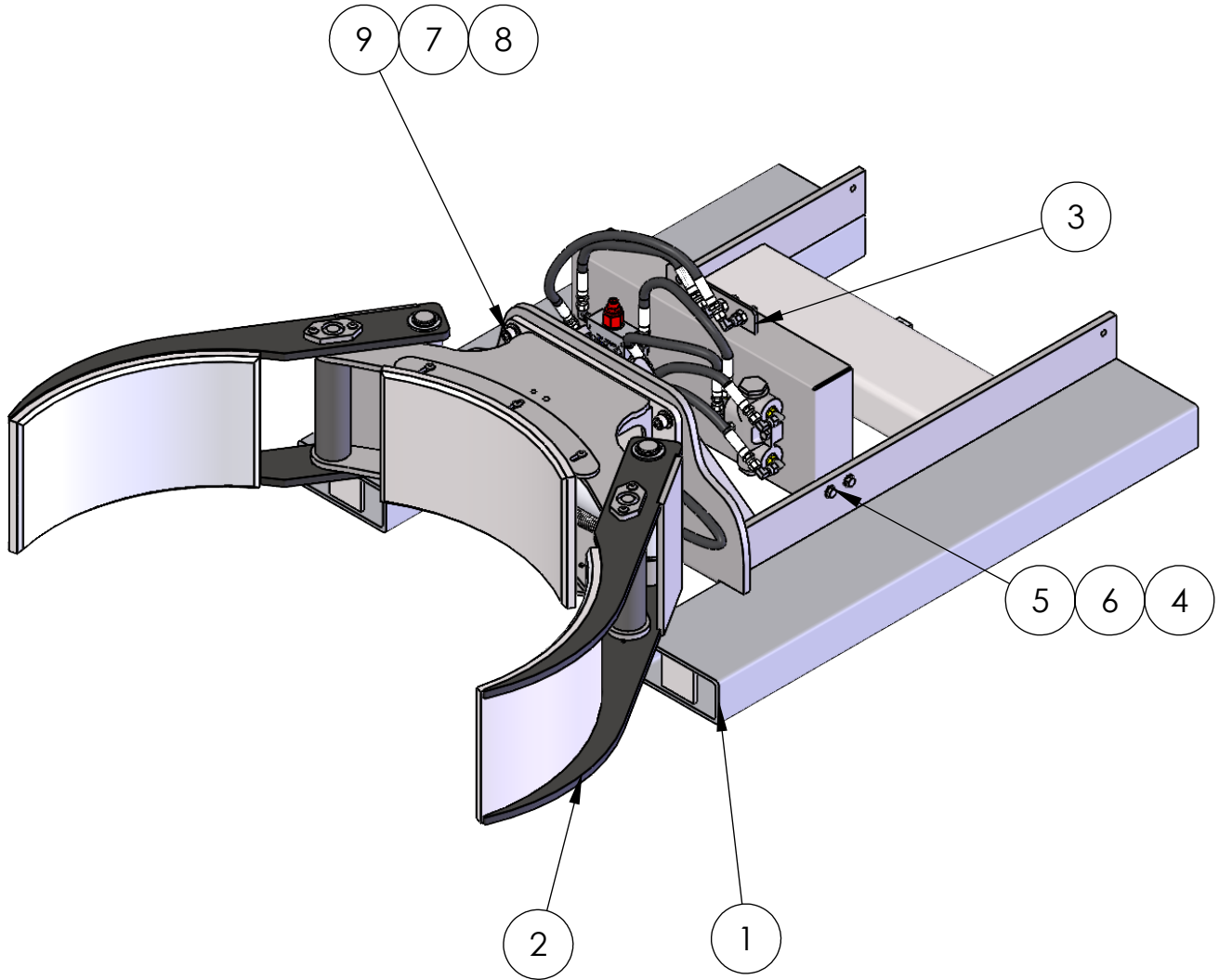

| ITEM NO. | PART NUMBER | DESCRIPTION             | QTY. |
|----------|-------------|-------------------------|------|
| 1        | F60558A9    | MAXI-FRAME-WELDMENT     | 1    |
| 2        | F60559A0    | UG-JAW ASSY 18-28 MAXI  | 1    |
| 3        | F60563A4    | VALVE MNT MAXI L/T ASSY | 1    |
| 4        | Z10036A6    | NUT-HEX KEPS 5/16-18    | 4    |
| 5        | Z10124A9    | S-HHC 5/16-18X1-1/4     | 4    |
| 6        | Z10200A6    | WASHER-1/4 FLAT USS     | 8    |
| 7        | Z10216A8    | WASHER-1/2 LOCK MD      | 4    |
| 8        | Z10331A8    | WASHER-1/2 FLAT SAE     | 4    |
| 9        | Z11555A0    | S-SHC 1/2-13X1-1/4      | 4    |

# MAXI II-2K# LT, CLAMP ONLY

## F60559A0 UG-JAW ASSY 18-28 MAXI EXPLODED VIEW

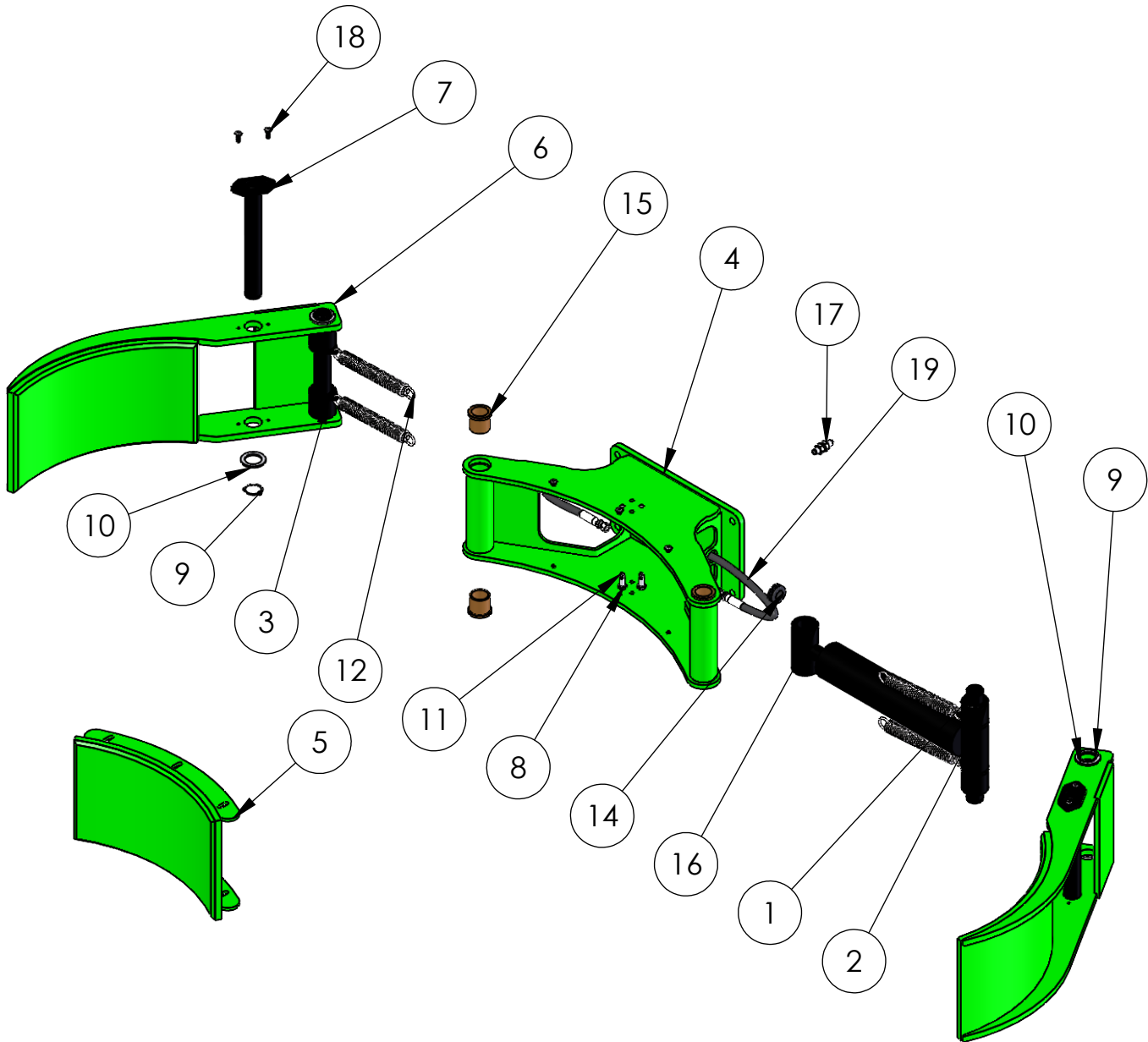

# MAXI II-2K# LT, CLAMP ONLY

## F60559A0 UG-JAW ASSY 18-28 MAXI Bill of Materials

| ITEM NO. | PART NUMBER | DESCRIPTION  | QTY. |
|----------|-------------|--|------|
| 1        | F50401      | CYL PIN 1.25 UG3 FRT SECT (KAN BAN)                | 2    |
| 2        | F50435      | RD-2.00/UG3 JAW ASSY CYL SPCR                      | 4    |
| 3        | F50438      | SHT-.19/UG3 JAW ASSY SPRG CLIP<br>(STK)            | 4    |
| 4        | F60560A1    | ARM WLDMT MAXI II                                  | 1    |
| 5        | F68824A2    | UG-JAW-SADDLE WLDMT-15-30 (9")<br>(STK)            | 1    |
| 6        | F68825A3    | UG-JAW-WLDMT-18-28 (9") (STK)                      | 2    |
| 7        | F68832A0    | UG-JAW-PIN WLDMT-20-35                             | 2    |
| 8        | Z10026A8    | NUT-HEX JAM 3/8-16ZP                               | 4    |
| 9        | Z10534A4    | RING-RTNG 1-1/4                                    | 6    |
| 10       | Z10592A2    | BUSH-MACH 1-1/4X10GA ZP                            | 6    |
| 11       | Z11484A3    | CONNECTOR 3/8-16 SPRING                            | 4    |
| 12       | Z11485A2    | SPRING-EXTENSION 1.00X.14X8.00                     | 4    |
| 13       | Z20616A6    | FTG 90 6801-4-4 NWO                                | 2    |
| 14       | Z20813A0    | GROMMET-.75IDX1.06HOLEX.25TH                       | 2    |
| 15       | Z20830A3    | BRG-BRZ-FLG 1.25X1.50X1.50                         | 4    |
| 16       | Z20845A8    | CYL ASSY-UG3 CLAMP 1.13ROD<br>(319392) (STKG PRGM) | 1    |
| 17       | Z84897A3    | FTG STR 2700-4-4-LN                                | 2    |
| 18       | Z11572A7    | S-BHCS 1/4-20X3/4 ZINC                             | 10   |
| 19       | F61348A1    | HOSE-20.00/613/649                                 | 2    |



MAXI II-2K# LT, CLAMP ONLY

**F60563A4 VALVE MNT MAXI L/T ASSY**  
Exploded View and Bill of Materials

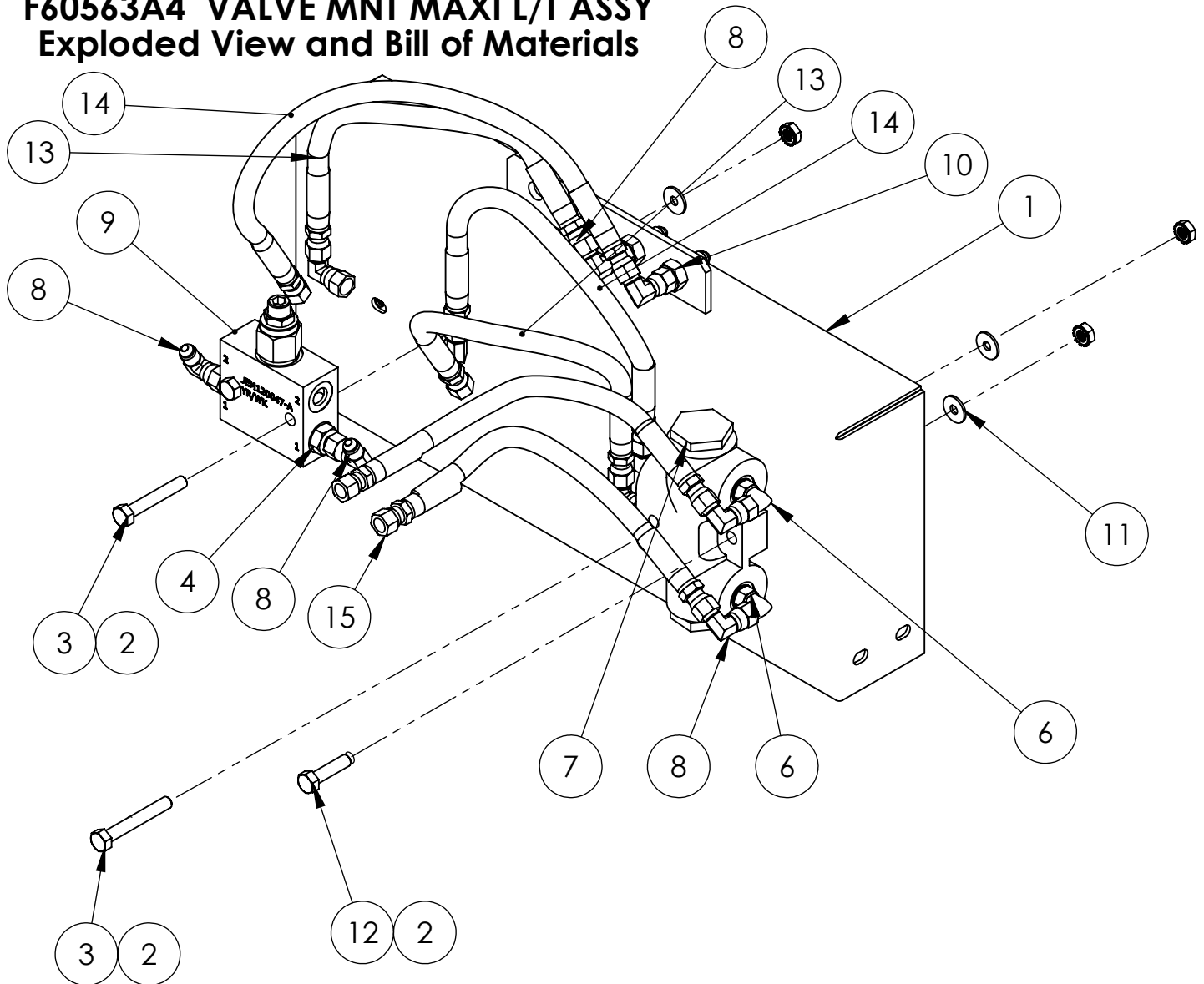

| ITEM NO. | PART NUMBER | DESCRIPTION                    | QTY. |
|----------|-------------|--------------------------------|------|
| 1        | F60562A3    | VALVE MNT MAXI L/T WLDMT       | 1    |
| 2        | Z10036A6    | NUT-HEX KEPS 5/16-18           | 4    |
| 3        | Z10158A8    | S-HHC 5/16-18X2 HT             | 3    |
| 4        | Z20597A5    | FTG STR 6400-4-6-O             | 2    |
| 5        | Z20615A7    | FTG STR 6400-4-4-O             | 1    |
| 6        | Z20616A6    | FTG 90 6801-4-4 NWO            | 3    |
| 7        | Z20650A2    | VALVE-LOCK 2000PSI/SAE         | 1    |
| 8        | Z20704A0    | FTG 90 6500-4-4 SWL            | 9    |
| 9        | Z20783A7    | PRESSURE REDUCE VALVE W/HOUSIN | 1    |
| 10       | Z84897A3    | FTG STR 2700-4-4-LN            | 2    |
| 11       | Z10200A6    | WASHER-1/4 FLAT USS            | 8    |
| 12       | Z10124A9    | S-HHC 5/16-18X1-1/4            | 1    |
| 13       | F61310A9    | HOSE-13.00/613                 | 2    |
| 14       | F61297A2    | HOSE-16.50/613                 | 2    |
| 15       | F61318A1    | HOSE-11.00/613                 | 2    |

# MAXI II-2K# LT, CLAMP ONLY

## HYDRAULIC SCHEMATIC

Z20845A8 CYL ASSY-UG3 CLAMP 1.13ROD  
 2.5" Bore  
 1.125" Rod  
 9.5" Stroke

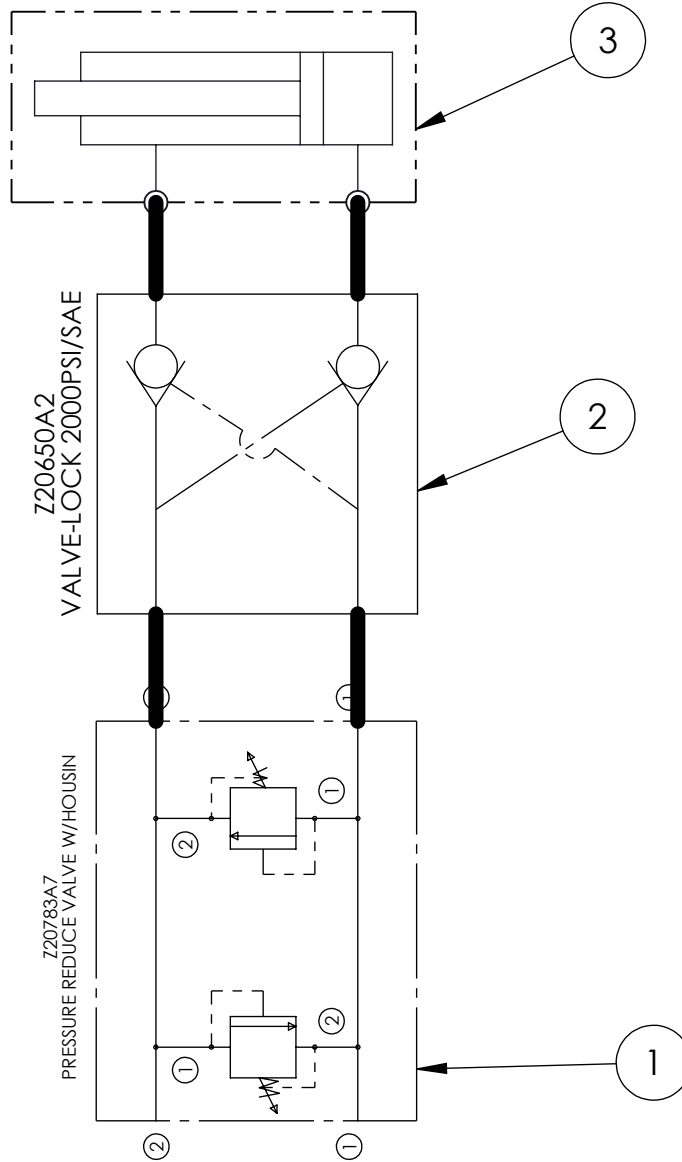

| ITEM | PART NO. | DESCRIPTION                    | QTY |
|------|----------|--------------------------------|-----|
| 1    | Z20783A7 | PRESSURE REDUCE VALVE W/HOUSIN | 1   |
| 2    | Z20650A2 | VALVE-LOCK 2000PSI/SAE         | 1   |
| 3    | Z20845A8 | CYL ASSY-UG3 CLAMP 1.13 ROD    | 1   |
| 3A   | 783-104  | KIT-SEAL 2.5" SCREW IN GLAND   | 1   |
| 3B   | 783-119  | KIT-SEAL 2.5" PISTON           | 1   |

# MAXI II-2K# LT, CLAMP ONLY

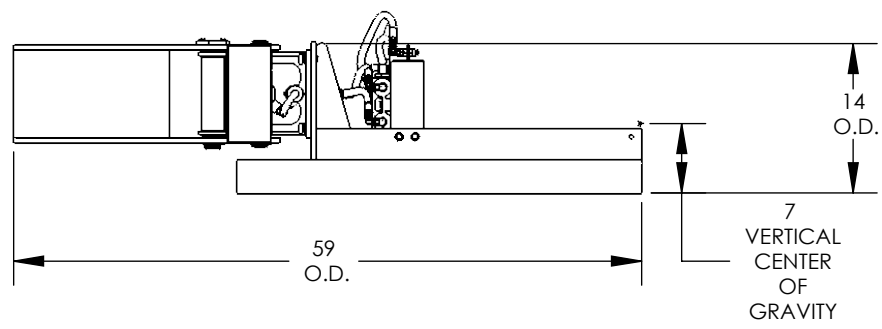
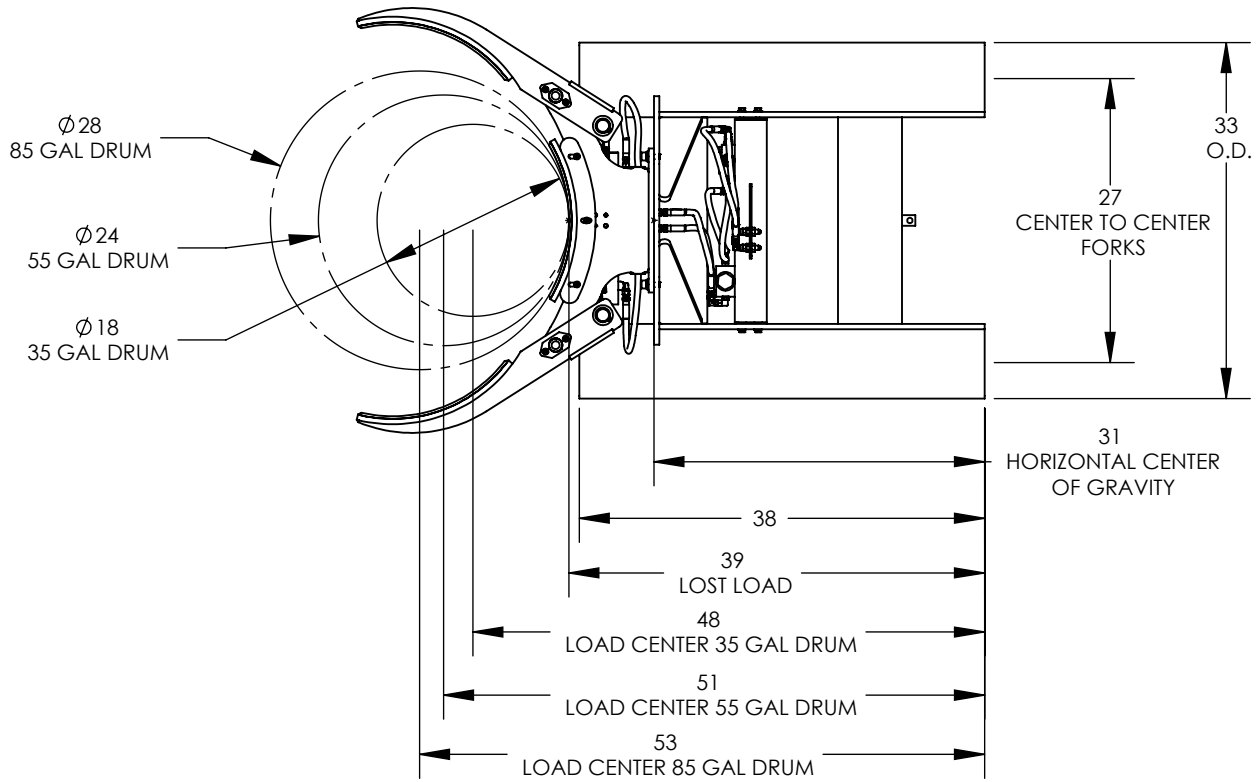

NOTES:

$\triangle A$  : LOAD CAPACITY 2000LBS

$\triangle B$  : WEIGHT 500

$\triangle C$  : CONTACT LIFT TRUCK MANUFACTURER FOR DOWNRATED CAPACITY

# Warranty and Limitation of Liability

Valley Craft products are warranted for a period of one (1) year from date of shipment from Valley Craft's plant to be free from defects in material and workmanship under correct use, normal operation and proper application. However, parts of other than Valley Craft manufacture are subject ONLY to the original manufacturer's warranty. Valley Craft's obligation under warranty shall be limited to repair or exchange, at Valley Craft's option, FOB origin factory, of any Valley Craft product or part which proves to be defective as provided herein. Valley Craft reserves the right to either inspect the product at Buyer's location, or require it to be returned to the factory for inspection. The warranty contained herein does not extend to goods damaged, or subject to accident, abuse or misuse after shipment from Valley Craft's factory, nor to goods altered or repaired by anyone other than an authorized Valley Craft representative.

Buyer or user shall not alter, modify or use a Valley Craft product for anything other than its intended function. Valley Craft shall not in any way be responsible for the consequences of any such alteration, modification or misuse.

VALLEY CRAFT MAKES NO EXPRESS WARRANTIES OTHER THAN THOSE WHICH ARE SPECIFICALLY DESCRIBED HEREIN. Any description of the goods sold hereunder, including any references to Buyer's specifications and any descriptions in catalogs, circulars and other written material published by Valley Craft, is for the sole purpose of identifying such goods and shall not create an express warranty that the goods shall conform to such descriptions.

THIS WARRANTY IS EXPRESSLY IN LIEU OF ALL OTHER WARRANTIES, EXPRESS OR IMPLIED. THERE ARE NO IMPLIED WARRANTIES OF MERCHANTABILITY OR FITNESS FOR A PARTICULAR PURPOSE. THIS WARRANTY STATES VALLEY CRAFT'S ENTIRE AND EXCLUSIVE LIABILITY AND BUYER'S EXCLUSIVE REMEDY FOR ANY CLAIM OR DAMAGES IN CONNECTION WITH VALLEY CRAFT PRODUCTS, THEIR DESIGN, SUITABILITY FOR USE, INSTALLATION OR OPERATION OR FOR ANY CLAIMED DEFECTS. VALLEY CRAFT WILL IN NO EVENT BE LIABLE FOR INCIDENTAL OR CONSEQUENTIAL DAMAGES WHATSOEVER, NOR FOR ANY SUM IN EXCESS OF THE PRICE RECEIVED FOR THE GOODS FOR WHICH LIABILITY IS CLAIMED.

## Technical Assistance/Warranty Procedure

### What's Covered:

- Parts and Labor to correct manufacturer's defect within one year of purchase.
- Freight Cost

### What's Not:

- Normal wear items (seal kits, bearings, tires, etc.)

### What Voids the Warranty:

- Dirt/Grime that directly causes malfunction of product
  - Abuse (i.e. Overloading, damaged, not properly maintained, etc.)
  - Product altered by customer
- \*See "Items not Under Warranty" below for items that have the warranty voided.

### Items Under Warranty (less than one year old):

- Warranty replacement parts are provided only when the problem can be identified with near certainty. If not, the customer will return item to Valley Craft, freight collect, for troubleshooting and/or repair. When repaired, product will be returned to customer, freight prepaid. Otherwise, customer may call local authorized service technician for assistance. . Under this arrangement, replacement parts will be sent at no charge but labor costs will NOT be covered.

### Items NOT Under Warranty (greater than one year old or "having warranty voided):

- Customer will return item to valley Craft, freight prepaid, for troubleshooting and/or repair. Valley Craft will call customer with \$\$ estimate of parts and labor for approval before repairing. Product will be returned to customer, freight collect.  
Or Customer may call local authorized service technician for repairs at their own expense.



Valley Craft is a modern metals fabricating manufacturer specializing in material handling, storage and specialized solutions designed with safety and usability in mind, and the simplification of even the heaviest of workloads. Since developing the first hand truck with a brake in 1952. Valley Craft has been a true pioneer in safety-conscious material handling and solution-driven products. Our commitment to continuous improvement in a Lean Manufacturing environment results in safe, functional, quality equipment at affordable prices.

**Valley Craft Industries, Inc.**

2001 South Highway 61

Lake City, MN 55041 U.S.A.

**Phone:** (651) 345-3386

**Fax:** (651) 345-6535

**E-Mail:** [customerservice@valleycraft.com](mailto:customerservice@valleycraft.com)

**Website:** [valleycraft.com](http://valleycraft.com)