

SOLUTIONS TO SIMPLIFY YOUR WORKLOAD

Material Handling, Storage & Specialized Equipment

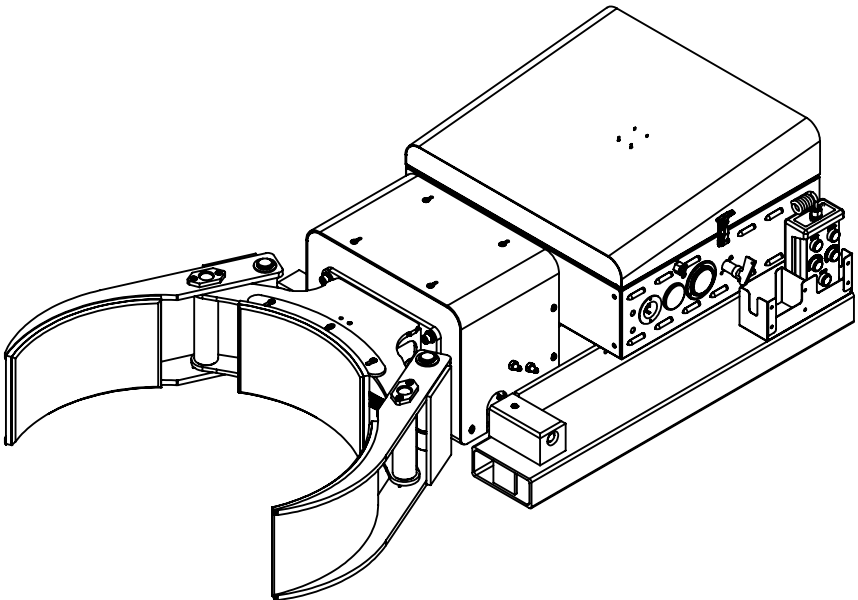

VERSA II-2K# STD SP F89701



Notice to Purchaser

All statements, technical information, and recommendations related to Valley Craft's products are based on information believed to be reliable, but the accuracy or completeness is not guaranteed. Before using this product, you must determine if it is suitable for your intended application or situation. You assume all risks and liability associated with such use or implementation.

Product Testing

We perform vigorous in-house safety and durability testing to ensure that the performance of our products meets the demands of the workplace. We also expect the same from manufacturers who supply components for our products. We do this to ensure that Valley Craft is a name that our customers trust and associate with quality.

Publication Revision Notice

Following is a history of changes to this publication, including the current revision.

Previously Updated: 05/13

Last Updated: 09/15

Copyright Notice

© Valley Craft, Inc. All rights reserved. No part of this publication may be reproduced, photocopied, stored on a retrieval system, or transmitted without the express written consent of Valley Craft.

Trademarks

The Valley Craft logo is a Valley Craft Trademark. All other company or product names are trademarks or registered trademarks of their respective owners. Use of a term in this document should not be regarded as affecting the validity of any trademark or service mark.

■ Table of Contents

Safety	4-6
Safety Overview	4
Safety Message Conventions	5
Material Safety Data	6
Product Description	7
Specifications	7
Features	7
Unpacking and Assembly	8
Receiving and Inspection	8
Operation	9-11
Operating Procedure Wired Pendant	9
Operating Procedure Battery Discharge Gauge	10
Operating Procedure Safety	11
Maintenance and Adjustments	12
Maintenance and Adjustment Procedures	12
Troubleshooting.....	13
Trouble Shooting Procedures	13
Replacement	14
Replacement Procedures	14
Parts List.....	15-20
Exploded View Jaw Assy	15
BOM Jaw Assy	16
Exploded View and BOM Clamp/Rotator Assy	17
Exploded View Control Box Assy	18
BOM Control Box Assy.....	19
Exploded View and BOM UGIII	20
Equipment Drawings	21-24
Hydraulic Schematic	21
Electrical Schematic.....	22
Wired Pendant Schematic	23
Lost Load Info	24

Safety

Read and understand all safety information and become familiar with all safety symbols contained in this section before moving, operating or performing maintenance on this equipment.

■ Safety Overview

The following general safety precautions must be observed during all phases of operation, service, and repair of this equipment. Failure to comply with these precautions or with specific safety messages elsewhere in this manual may impair the protection provided by the equipment. Such noncompliance would also violate safety standards of design, manufacture, and intended use of the instrument.

- Observe all safety signs posted in your facility.
- Observe warnings, cautions, handling information, storage requirements and other information on all container labels.
- Wear safety glasses with side shields.
- Wear the proper protective clothing, gloves and other protective equipment before handling any chemicals.
- Group the containers for the move by Hazard Class. Do not move acids with toxics, or oxidizers.
- Use maximum care and good judgment in preventing accidents and injuries and seeking first aid.
- Report unsafe conditions, equipment, practices, and on-job injuries.
- Understand your supervisor's instructions. Ask questions if you do not know how to do the job safely.
- Do not engage in tasks which you believe might be unsafe without consulting your supervisor.
- Clean up the work area and equipment upon job completion.
- Before you start work on any electrical system or circuit, check all power sources to ensure that the system or circuit is de-energized.
- Know the hazardous or potentially hazardous substances you work with or are present in your work area. Review Material Safety Data Sheets (MSDS) on these substances, or contact your supervisor.
- **Please review more detailed safety information on page 12.**

■ Safety Message Conventions

Three types of safety notices may be contained in this manual: **Danger**, **Warning** and **Caution** notices. These notices precede the procedural step or portion of text that presents the safety hazard.



DANGER

- **DANGER** indicates an imminently hazardous situation which, if not avoided, will result in death or serious injury. This signal word is to be limited to the most extreme situations.
-



WARNING

- **WARNING** indicates a potentially hazardous situation which, if not avoided, could result in death or serious injury.
-



CAUTION

- **CAUTION** indicates a potentially hazardous situation which, if not avoided, may result in minor or moderate injury. It may also be used to alert against unsafe practices
-

■ Material Safety Data Sheets (MSDS)

A Material Safety Data Sheet (MSDS) provides information on the safe use, handling and potential hazards of a product. This information assists with the proper response in the event of an emergency.

Valley Craft maintains material safety data sheets (MSDSs) on all our products. You are urged to obtain copies of the relevant MSDSs before using our products to protect yourself and others against any known health or safety hazards described in these MSDSs. Valley Craft strives to make safety a top priority. Do not hesitate to contact us to discuss any safety aspects of our products.

The relevant MSDS codes for Valley Craft products are listed below.

- www.conocophillips.com
Super ATF Transmission Oil, MSDS Code 778846
Super-Sta Grease, MSDS Code 775440
- www.batteriesplus.com
Sealed Lead Acid Battery
SLA for English version
SLA Sp for the Spanish version
- [Paint](#)
Contact Valley Craft Customer Service at 1-800-328-1480 or on the Web at customer@valleycraft.com

■ Additional Safety Information

As with any mechanical device, care must be taken during the installation, operation, and maintenance of the device in order to realize the maximum benefit from its ownership.

Note: All personnel involved in the use and maintenance of this device should be thoroughly familiar with the information contained in this manual. Furthermore, it is recommended that all personnel be given adequate instruction and a sufficient period of training in its actual use to insure safety of personnel and proper care of the equipment. It is suggested that the units be initially operated empty until becoming familiar with operation of this unit.

Product Description

The Versa II is a self-powered lift truck attachment which allows the operator to manipulate drums from most lift trucks without any additional equipment. It offers the ability to clamp and forward dump most sizes and types of drums.

■ Specifications

The Versa II specifications are shown in Table 1.

Table 1. Specifications

Dimensions	33"Wx67"Lx18"H
Weight	850 lbs
Load Capacity	2000 lbs

■ Features

The Versa II offers state-of-the-art design with many advanced features.

- 120° forward dumping
- Rugged, light plastic, pendant control
- Key Switch disconnects main power
- System pressure gage
- Battery discharge indicator (BDI)
- On board charging system
- Clamping system that clamps steel, fiber, and plastic drum

■ Receiving and Inspecting

When unpacking the Versa II, inspect the equipment for damage or mishandling. If damage is noted, file a damage claim with the carrier within 24 hours and call Valley Craft at 1-800-328-1480. Do not attempt to use the equipment.

Compare the contents of the shipment with the bill of lading. Report any missing items to the carrier and to Valley Craft immediately.

■ Operating Procedures

Only authorized personnel are permitted to use the Versa II. Every load and every situation is different. Every load must be evaluated and planned. Observe the following procedures when using this equipment.

All personnel should be given adequate instruction and a sufficient period of training in actual use of the attachment to insure safety and proper care. The Versa II is intended for use with sealed containers.

1. Insert forks of lift truck into fork tube of drum grip.
2. Attach safety chain to clevis on rear of frame and wrap chain around forklift carriage and clip the safety hook.
3. Turn attachment on.
4. Secure control box near the forklift drivers seat.
5. Advance lift truck until jaws of drum grip center around the drum.
6. Grip drum in center at all times.
7. Activate clamping pressure by depressing the clamp button. To unclamp press safe button and unclamp button at same time. Two handed control helps prevent accidental operations.
8. To dump drums, depress the appropriate button.
9. If drum grip needs to be removed from forklift, set unit down, remove safety chain from around carriage, replace control box unit, and back away from the drum grip.

VERSA II-2K# SP, CLAMP & TILT

■ Operating Procedures Wired Pendant

Only authorized personnel are permitted to use the Versa II. Every load and every situation is different. Every load must be evaluated and planned. Observe the following procedures when using this equipment. The following describes how to operate the unit with the cabled pendant.



	CLAMP BUTTON	ROTATE BUTTON	TILT/LIFT BUTTON	SAFE BUTTON
CLAMP OPEN	X			X
CLAMP CLOSE	X			
ROTATE RIGHT		X		
ROTATE LEFT		X		

VERSA II-2K# SP, CLAMP & TILT

■ Operating Procedures Z20836A7 GAUGE-BATTERY DISCHARGE



Configuring Your Gauge

Access to these operations is sequential in this order. Adjustments of the following functions can be performed in the configuration mode.

1. Time-of-Day Clock

During configuration, the right button is used to increment. The left button is used to

1. Enter a selection
2. Advance to the next configurable item

If no change is desired to a specific gauge function, continue to press the left button until the next desired function is reached. The time-of-day clock is entered by setting the hours digits between 01 and 12, then 'minutes' digits between 00 and 59.

Setting the Time-of-Day Clock

The display will flash the two 'hours' digits. Press the right button to increment by one hour, or hold the button to increment continuously. When the desired number of hours is reached, press the left button once. The display will flash the two 'minutes' digits. Press the right button to increment by one minute or hold the button to increment continuously. When the desired number of minutes is reached, press the left button once.

Configuration Notes

The gauge remains in configuration mode for 30 seconds without input from the user. When configuring each function you must enter in all data for that function for it to be saved. If incomplete data is entered for a function and the programming mode is timed out (after 30 seconds of no input received by the gauge), the gauge will revert back to what was previously stored for that item.

Exiting Configuration Mode

The configuration mode can be exited in three ways?

1. Press and hold the left button for three seconds.
2. Leave buttons untouched for 30 seconds.
3. Press the left button after selecting the last (right) digit of the last function available.

Toggling Display Functions

Press the left button to sequentially toggle between the three numeric gauge functions (time-of-day clock, maintenance hours, total hours).

LCD Icons

1. Hourglass Icon – Turned on (not blinking) to indicate that an hour meter is displayed in the numeric display. Flashes to indicate hour meter accumulation.
2. Battery Icon – Turned on (not blinking) to indicate function. It flashes when a low condition is detected.
3. Colon – Flashes to indicate that the time-of-day clock is being displayed in the numeric display and that time is counting-up.
4. Decimal Point – To indicate 1/10 of a volt for the BDI profile.
5. Percent – Indicates remaining percentage of interval or level.

Troubleshooting

Problem	Possible Causes
No display	Terminals not connected Improper voltage
Stays at full	Instrument voltage does not match battery voltage V+ connected to wrong terminal
Will not reset	Instrument voltage does not match battery voltage Battery not fully charged Defective battery
Resets without charging	Not connected to battery terminal
Empty too soon	V+ connected to wrong terminal Instrument voltage does not match battery voltage Terminals not connected to battery
Cannot configure	No power to the setup enable pin

Safety

Read and understand all safety information and become familiar with all safety symbols contained in this section before moving, operating or performing maintenance on this equipment.



CAUTION

- It is recommended that all operators practice operation of the Versa II and its controls with an empty drum before using it on full drums to familiarize themselves with the machine and to develop safe working habits.
- Too much pressure applied to the drum will cause crushing.
- Never activate the clamping function while the forklift is in motion.
- When dumping drums, dump slowly, watching for drum distortion as contents are dumped. The dumping capacity is limited by the strength of the container being dumped (an open top drum must be capable of retaining its original cylindrical shape). A distorted drum may fall out of the grip.
- Maximum lifting capacity is 2000 lbs. Actual capacity may be limited by the size of the lift truck. Always follow lift truck manufacturer's specifications.

■ Charging Batteries

1. Always turn the key to the “off” position when unit is not in use.
2. To charge your battery, plug a grounded extension cord into the built-in receptacle in the Control Box and an outlet (see below).
3. The battery will charge automatically after the charger is plugged in and can be left unattended.
 - Batteries will generally require equal charging to work time.
4. Keep the charger plugged in to maintain a full battery level when the unit is not being used.

NOTES:

- See charger **MANUAL** for **SAFETY PRECAUTIONS** and charger **TROUBLESHOOTING**.
- **DO NOT USE BATTERIES UNTIL THEY ARE TOTALLY DISCHARGED.**
 - i. Doing so may damage your battery.
 - ii. For maximum battery life, your unit is equipped with a charger that collects information from the battery and adjusts the current and voltage accordingly. If your battery voltage drops below a certain threshold the charger will not charge the battery.
- If the battery becomes discharged and won't charge by ordinary means, a suggested solution is to “trick” the charger into reading a higher voltage from the battery. To do this connect a second, well-charged battery (12.4 volts or greater) in parallel with the dead battery-positive to positive, negative to negative. Then plug in your charger and charge the combination until the dead battery has enough voltage to enable being charged by itself.

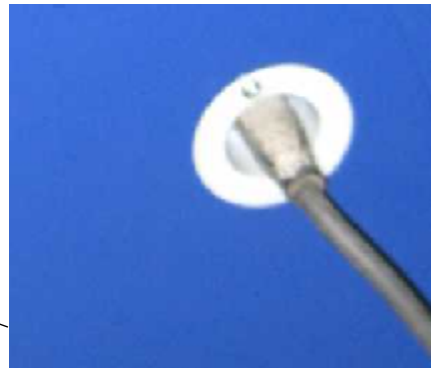
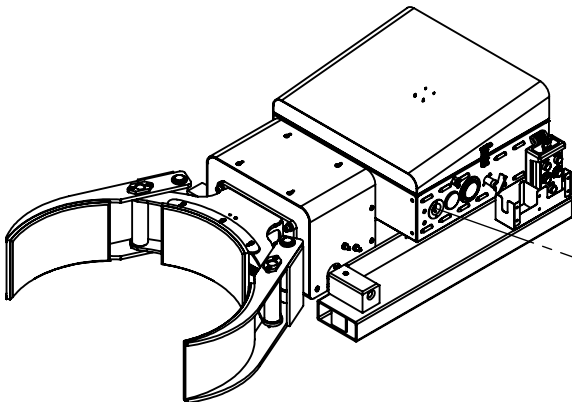

Maintenance and Adjustments

■ Maintenance and Adjustment Procedures

To keep the Versa II operating properly, timely maintenance and adjustments are required. These procedures should be performed only by qualified personnel who are familiar with the equipment.

Important:

- **Always disconnect and remove the batteries from the attachment before beginning an inspection or repair.**

Before each use:

1. Be sure the batteries are fully charged and free from damage.
2. Inspect safety chain and verify it is in good condition. Replace if necessary.
3. Inspect attachment for sharp edges or burrs.
4. Inspect hydraulic hoses for any leaks or punctures.

Every 6 months:

1. Inspect and grease pivot points.
2. Check hydraulic fluid. Correct fluid level is 1 to 2 inches from top of fluid fill/breather cap. Do not overfill. Use automatic transmission fluid only.
3. Inspect wiring harness for pinched wires or loose connections.
4. Inspect all fasteners and tighten if necessary.
5. Inspect battery charger and connections. Tighten if necessary.

Troubleshooting

■ Troubleshooting Procedures

The Versa II is a quality product that is designed and manufactured to provide prolonged service under normal operating conditions. If troubleshooting is required, it should be performed only by qualified personnel who are familiar with the equipment.

Problem	Possible Cause	Solution
Batteries will not charge	Faulty batteries	Load test batteries to ensure they are good. If bad replace.
	Faulty Charger	Verify if charger is outputting amperage. If bad replace.
Unit not functioning	Low/Dead batteries	Recharge batteries
	Improper grounding	Check motor & battery wire connections.
	Damaged or loose wiring	Check wiring to switches in control box.
Only certain functions operate	Damaged or loose wiring	Check wiring to switches in control box
	Bad switches	Replace
	Bad solenoids	Replace
Unit is crushing drums	Too much pressure	Grip drum just to the point that the drum starts to distort
Cylinder leaking	Worn/old o-rings	Replace seals in cylinder

Replacement

■ Replacement Procedures

Occasionally, it will be necessary to replace a part that has been Damaged or worn. Many parts on this Versa II are replaceable. If replacement of a part is required, it should be performed only by qualified personnel who are familiar with the equipment.

See page 16 for available replacement parts. Identify the part number you need. Contact Valley Craft Customer Service at 1-800-328-1480 or on the Web at customer@valleycraft.com.

Information required when contacting Valley Craft:

- A. Company name and address
- B. Contact persons name
- C. Telephone number
- D. E-Mail address
- E. Model Number
- F. Date of manufacture
- G. Part number(s) of part(s) to be ordered

The model number and date of manufacture is stamped on a metal tag located on the control box.

F60559A0 UG-JAW ASSY 18-28 MAXI
EXPLODED VIEW

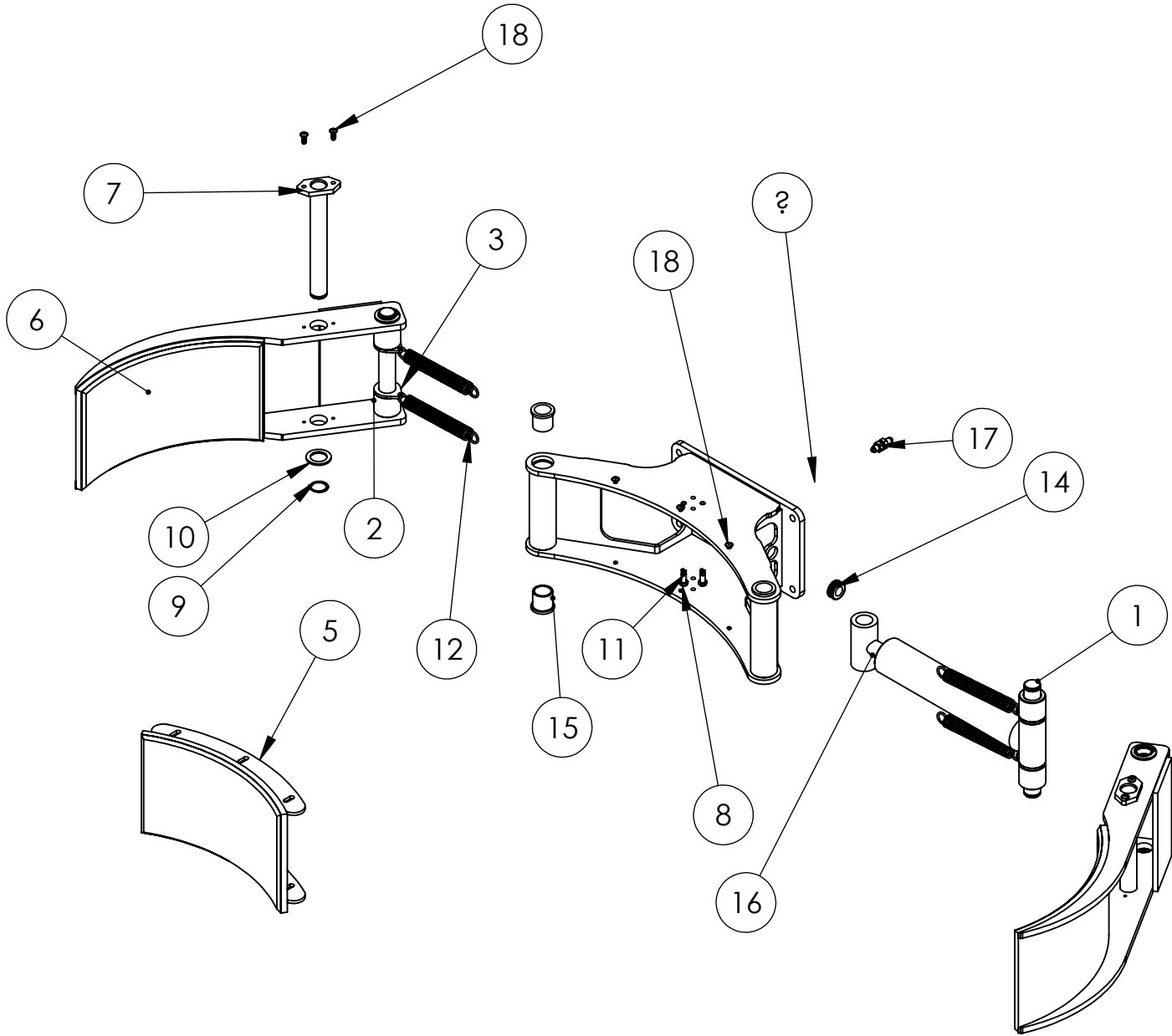

VERSA II-2K# SP, CLAMP & TILT

F60559A0 UG-JAW ASSY 18-28 MAXI
Bill of Materials

ITEM NO.	PART NUMBER	DESCRIPTION	EXP VIEW/QTY.
1	F50401	CYL PIN 1.25 UG3 FRT SECT (KANBAN)	2
2	F50435	RD-2.00/UG3 JAW ASSY CYL SPCR	4
3	F50438	SHT-.19/UG3 JAW ASSY SPRG CLIP	4
4	F60560A1	ARM WLDMT MAXI II	1
5	F68824A2	UG-JAW-SADDLE WLDMT-15-30	1
6	F68825A3	UG-JAW-WLDMT-18-28	2
7	F68832A0	UG-JAW-PIN WLDMT-20-35	2
8	Z10026A8	NUT-HEX JAM 3/8-16ZP	4
9	Z10534A4	RING-RTNG 1-1/4	6
10	Z10592A2	BUSH-MACH 1-1/4x10GA	6
11	Z11484A3	CONNECTOR 3/8-16 SPRING	4
12	Z11485A2	SPRING-EXTENSION 1.00X.14X8.00	4
13	Z20616A6	FTG 90 6801-4-4 NWO	2
14	Z20813A0	GROMMET-.75IDX1.06HOLEX.25TH	2
15	Z20830A3	BRG-BRZ-FLG 1.25X1.50X1.50	4
16	Z20845A8	CYL ASSY-UG3 CLAMP 1.13ROD	1
17	Z84897A3	FTG STR 2700-4-4-LN	2
18	Z11572A7	S-BHCS 1/4-20X3/4 ZINC	10

VERSA II-2K# SP, CLAMP & TILT

F69007A7 VERSA-CLAMP/TILT ASSY
Exploded View and Bill of Materials

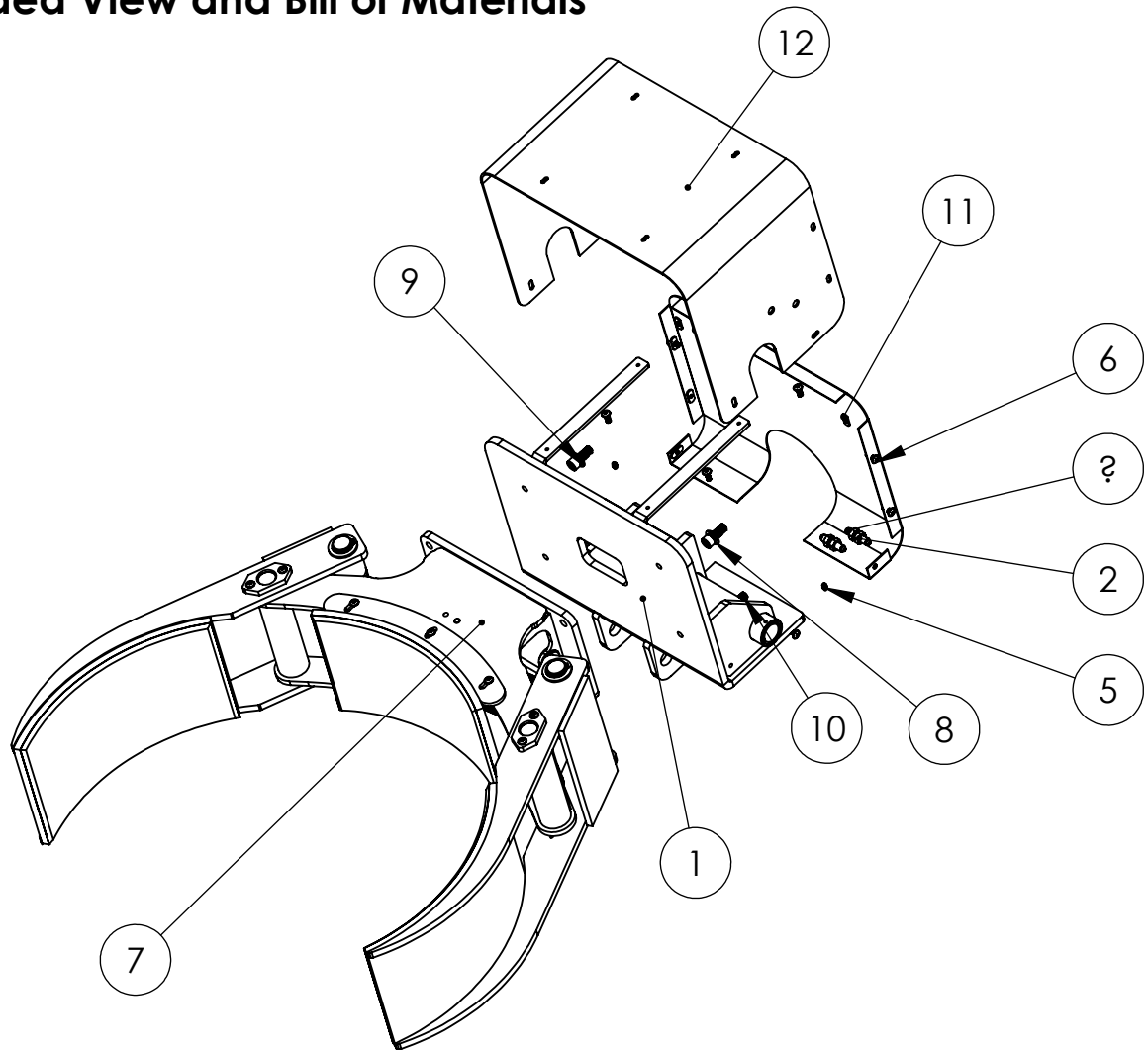

ITEM NO.	PART NUMBER	DESCRIPTION	LOCKED/QTY.
1	F69004A4	VERSA PIVOT ASSY	1
2	Z84897A3	FTG STR 2700-4-4-LN	2
3	Z11550A9	S-BHCS 1/4-20X1-1/4 ZINC	2
4	Z41645A5	DECAL-DANGER KEEP HANDS AWAY	2
5	Z10627A7	ZERK-GREASE .188 DRIVE	2
6	Z11572A7	S-BHCS 1/4-20X3/4 ZINC	8
7	F60559A0	UG-JAW ASSY 18-28 MAXI	1
8	Z10216A8	WASHER-1/2 LOCK MD	2
9	Z10331A8	WASHER-1/2 FLAT SAE	2
10	Z11555A0	S-SHC 1/2-13X1-1/4	4
11	F69003A3	VERSA BACK COVER ASSY	1
12	F51728	VERSA COVER	1

F60580A1 VERSA-CNRLBOX-ASSY
EXPLODED VIEW

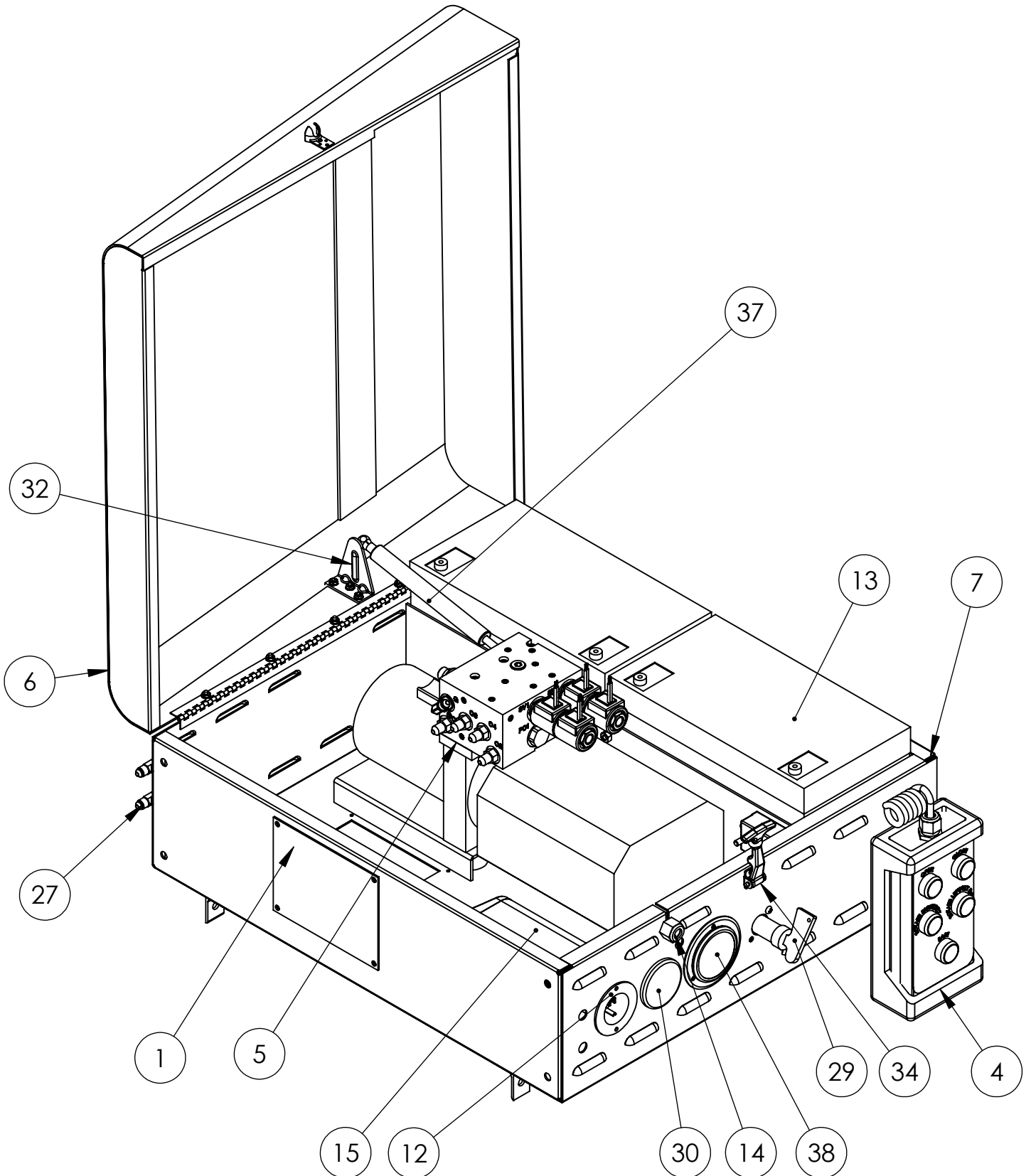

VERSA II-2K# SP, CLAMP & TILT

F60580A1 VERSA-CNRLBOX-ASSY
Bill of Materials

ITEM NO.	PART NUMBER	DESCRIPTION	Default/ QTY.
1	F50432	UG-CNRLBOX-ACCESS PANEL	2
2	F50804	FELT PAD UG3 BTM BAT 2.50X50"	1
3	F50805	FELT PAD UG3 TOP BAT 2.50X22"	1
4	F60573A4	PENDANT ASSY/FORK ATTACH	1
5	F60575A6	PP-2FUNC 12V	1
6	F68839A7	UG-CTL-LID WLDMT	1
7	F68840A8	UG-CNRLBOX- BASE WLDMT	1
8	Z00008A1	CIRCUIT BRKR SLA-150	1
9	Z00111A5	CABLE-BAT BLK 6LG	1
10	Z00113A3	CABLE-BAT RED 15.5LG	1
11	Z00114A2	CABLE-BAT BLK 15.5LG	3
12	Z00120A4	PLUG-FLGD INLET 125V	1
13	Z00171A6	BATTERY-12V 100AH SEALED LEAD	2
14	Z00407A5	CORD GRIP FOR 18/3	1
15	Z00546A4	CHRGR-BATTERY 12/24 120VAC	1
16	Z00547A3	CABLE-BAT 12V-27" RED 7/16X1/4	1
17	Z00548A2	CABLE-BAT 12V-6" RED 7/16X1/4	1
18	Z10003A5	NUT-HEX KEPS #4-40	3
19	Z10035A7	NUT-HEX KEPS 1/4-20	3
20	Z10176A6	S-RHM #10-24X1/2	5
21	Z10335A4	S-CRG 1/4-20x3/4 ZP	2
22	Z10382A6	NUT-HEX KEPS #8-32 ZP	11
23	Z10391A5	NUT-HEX KEPS #10-24	5
24	Z10463A8	S-PTHM #8-32x3/8	11
25	Z10595A9	RIVET-POP 1/8x1/8 ST	3
26	Z11548A1	S-FHM #4-40X3/8 ZP	3
27	Z20704A0	FTG 90 6500-4-4 SWL	2
28	Z20814A9	GROMMET-.75IDX1.13HOLEX.09TH	2
29	Z20818A5	SWITCH-BATTERY DISCONN/PD	1
30	Z20836A7	GAUGE-BATTERY DISCHARGE	1
31	Z20849A3	FTG 90 2502-4-4	1
32	Z84866A4	10MM BALL MOUNT PLATE TALL	1
33	Z84867A3	GAS SPRING END 10MM STEEL	2
34	Z84869A1	LATCH-DRAW RUBBER	1
35	Z84897A3	FTG STR 2700-4-4-LN	2
36	Z84905A5	GAS SPRING MOUNT STR	1
37	Z84906A4	GAS SPRING 60 LB 4" STROKE	1
38	Z84909A1	GAUGE-PRESSURE 0-3K PSIG	1

VERSA II-2K# SP, CLAMP & TILT

**F89701 VERSA II-2K# STD SP
ISO View and Bill of Materials**

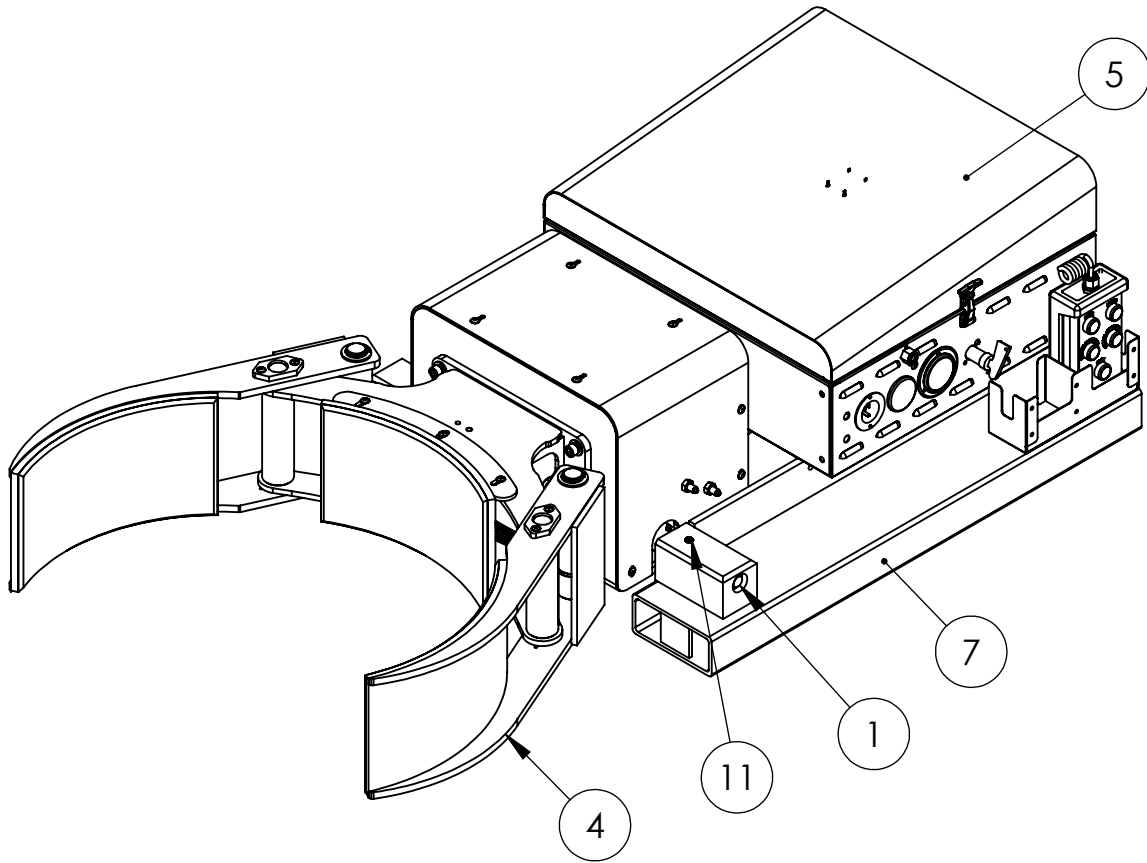

ITEM NO.	PART NUMBER	DESCRIPTION	QTY.
1	F50383	UG-RTB-AXLE	1
2	F50447	PIN-CLEVIS/TILT CASE	1
3	F51731	PIN-CLEVIS/TILT CASE (KANBAN)	1
4	F69007A7	VERSA-CLAMP/TILT ASSY	1
5	F60580A1	VERSA-CNRLBOX-ASSY	1
6	F68823A1	UG-PENDANT BOX WLDMT	1
7	F69005A5	VERSA-FRAME-WELDMENT	1
8	Z10013A3	BUSH-MACH 1x10GAx1-1/2 OD	10
9	Z10045A5	NUT-NYL NE 5/16-18	4
10	Z10223A9	RING-RTNG 1	4
11	Z10392A4	S-SHS 1/2-20X1/2	2
12	Z84912A8	CYL 3.5 X 1-1/4 X 8.25	1
13	Z10125A8	S-HHC 5/16-18X1-1/2	4
14	Z10337A2	S-PTHM #8x1/4 PL	4
15	Z20585A7	FTG 90 6801-4-6-NWO	2

VERSA II-2K# SP, CLAMP & TILT

HYDRAULIC SCHEMATIC

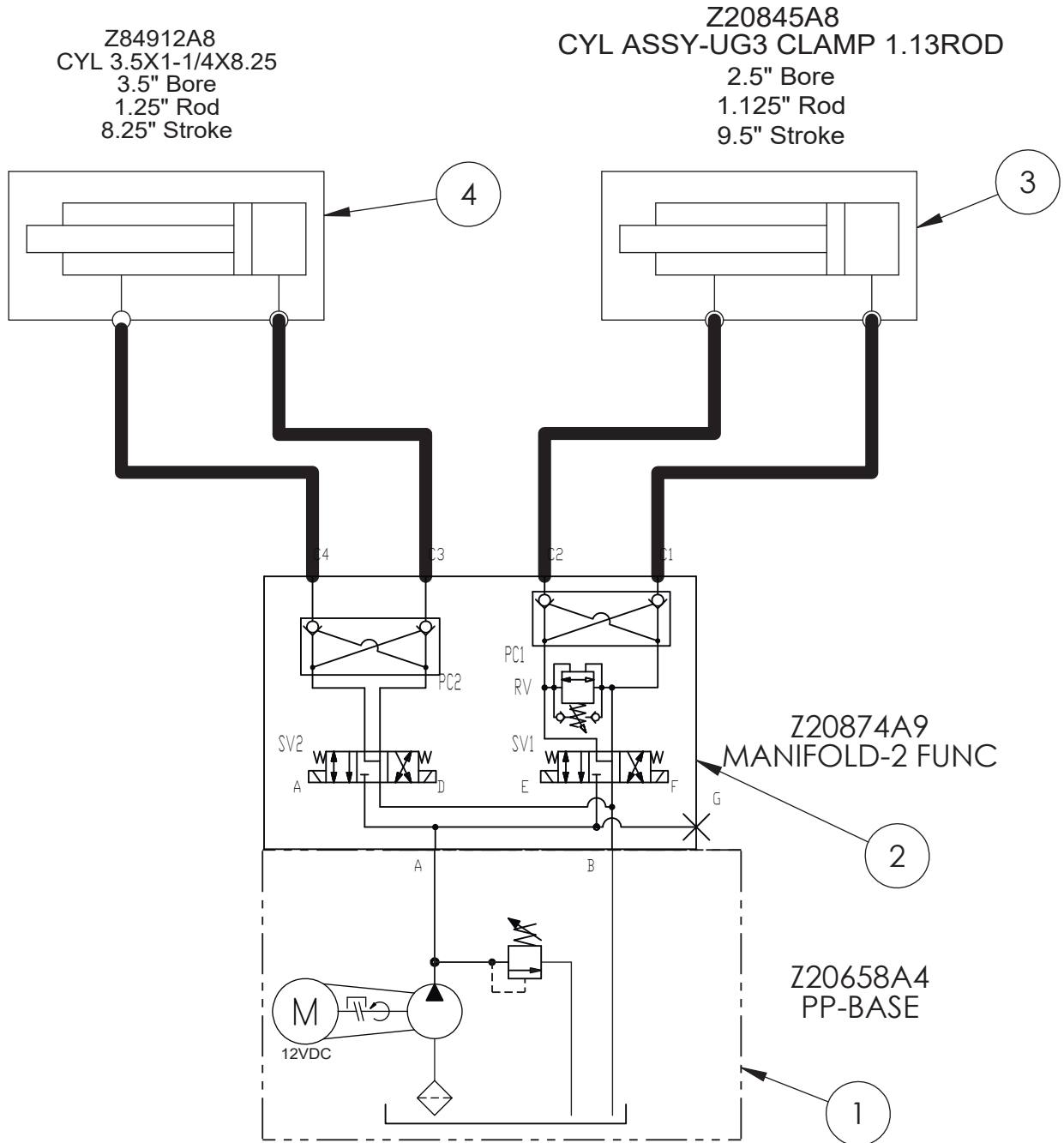

General Table			
ITEM	PART NO.	DESCRIPTION	QTY
1	Z20658A4	PP-BASE	1
2	Z20874A9	MANIFOLD-2 FUNC PRES REL	1
3	Z20845A8	CYL ASSY-UG3 CLAMP 1.13 ROD	1
3A	783-104	KIT-SEAL 2.5" SCREW IN GLAND	1
3B	783-119	KIT-SEAL 2.5" PISTON	1
4	Z84912A8	CYL 3.5X1-1/4X8.25	1
4A	R8491201	KIT-SEAL 3.5" TILT	1

VERSA II-2K# SP, CLAMP & TILT

ELECTRICAL SCHEMATIC

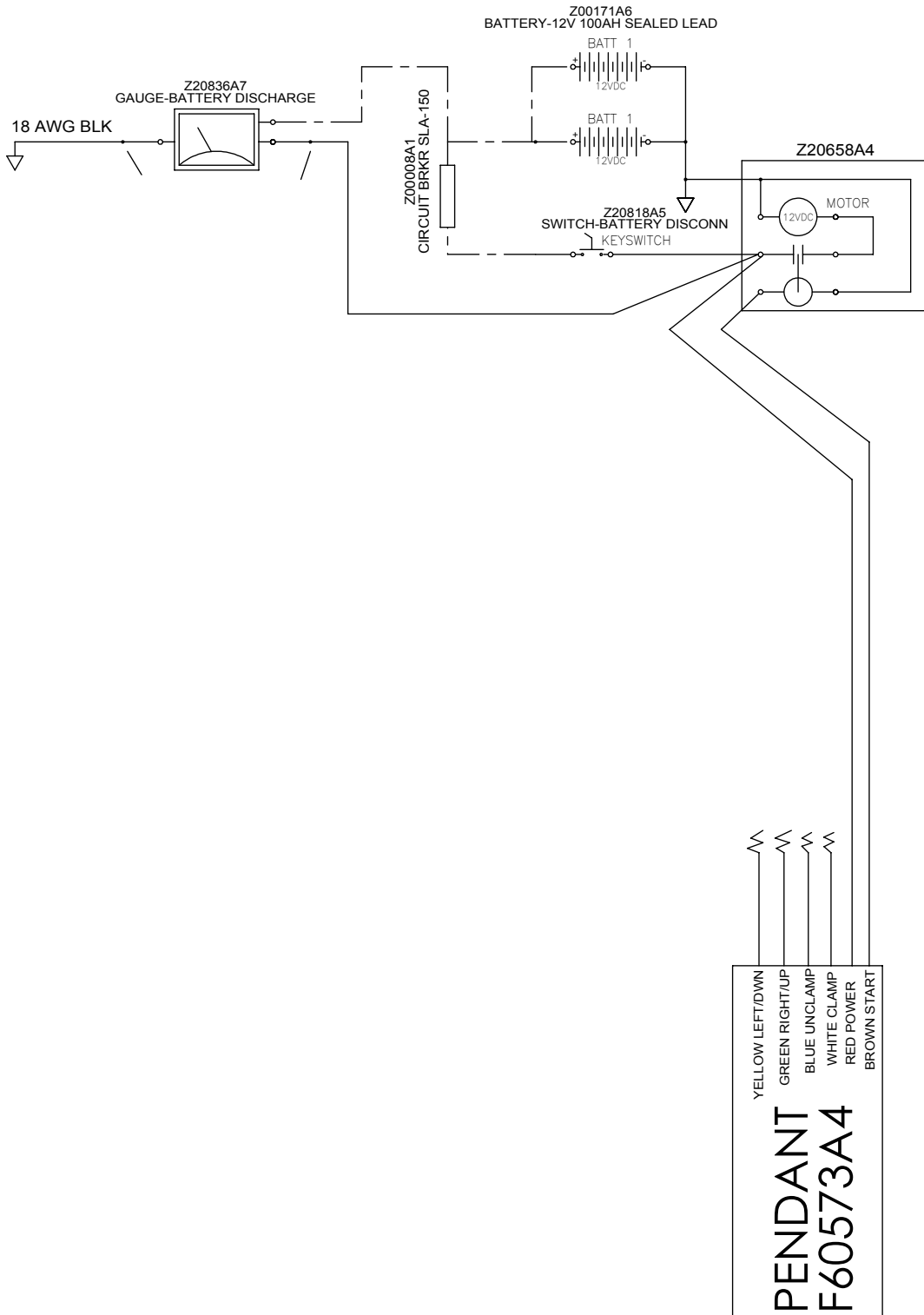

VERSA II-2K# SP, CLAMP & TILT

WIRED PENDANT
F60573A4 PENDANT ASSY/FORK ATTACH

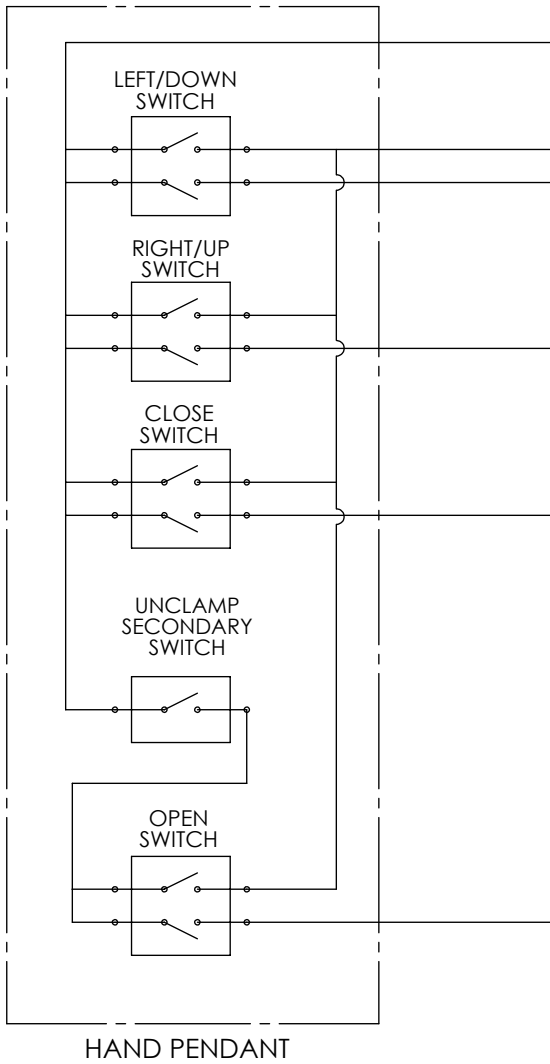

+12 VOLT POWER SOURCE (RED 6)

DC MOTOR START SOLENOID (BRN 5)
 LEFT/DOWN SOLENOID (YEL 1)

RIGHT/UP SOLENOID (GRN 2)

CLOSE SOLENOID (WHITE 3)

OPEN SOLENOID (BLU 4)

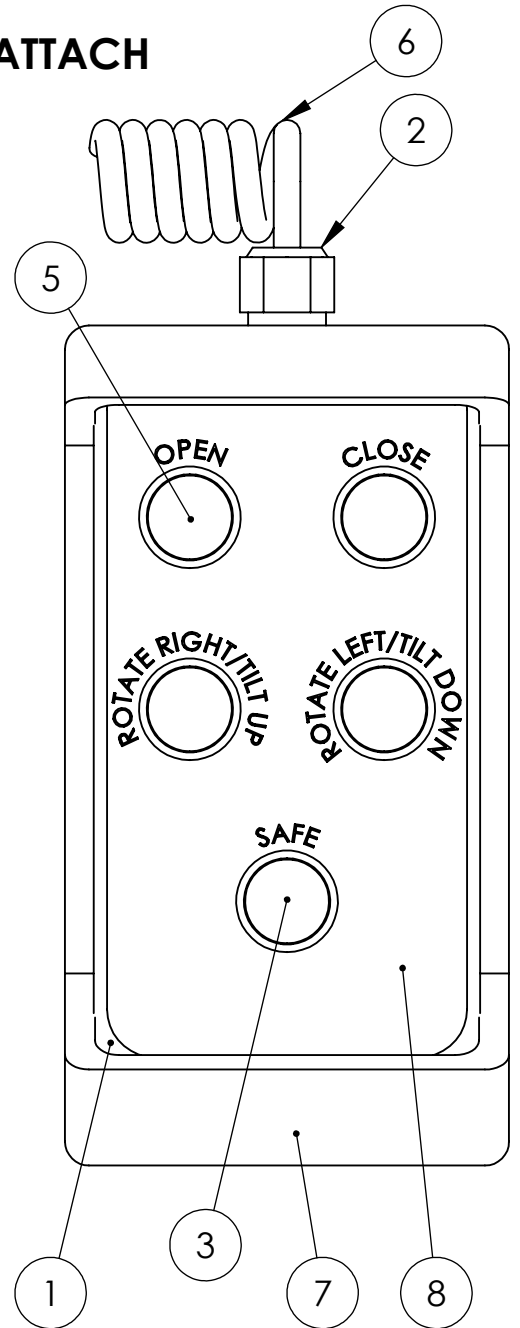

ITEM NO.	PART NUMBER	DESCRIPTION	QTY.
1	F51476	ENC-BOX PLST BLK DRLD	1
2	Z00407A5	CORD GRIP FOR 18/3	1
3	Z00522A8	PB-22MM MOM RED	1
4	Z00524A6	CONTACT BLOCK N/O	9
5	Z00555A5	PB-22MM MOM BLK	4
6	Z00556A4	CORD-COIL 6 18G 4-20	1
7	Z00557A3	ENC-BOOT RUBBER BLK	1
8	Z41281A8	DECAL-PENDANT FORK ATTACH	1
9	Z00462A0	NUT-LOCK ELEC 1/2-14	1

VERSA II-2K# SP, CLAMP & TILT

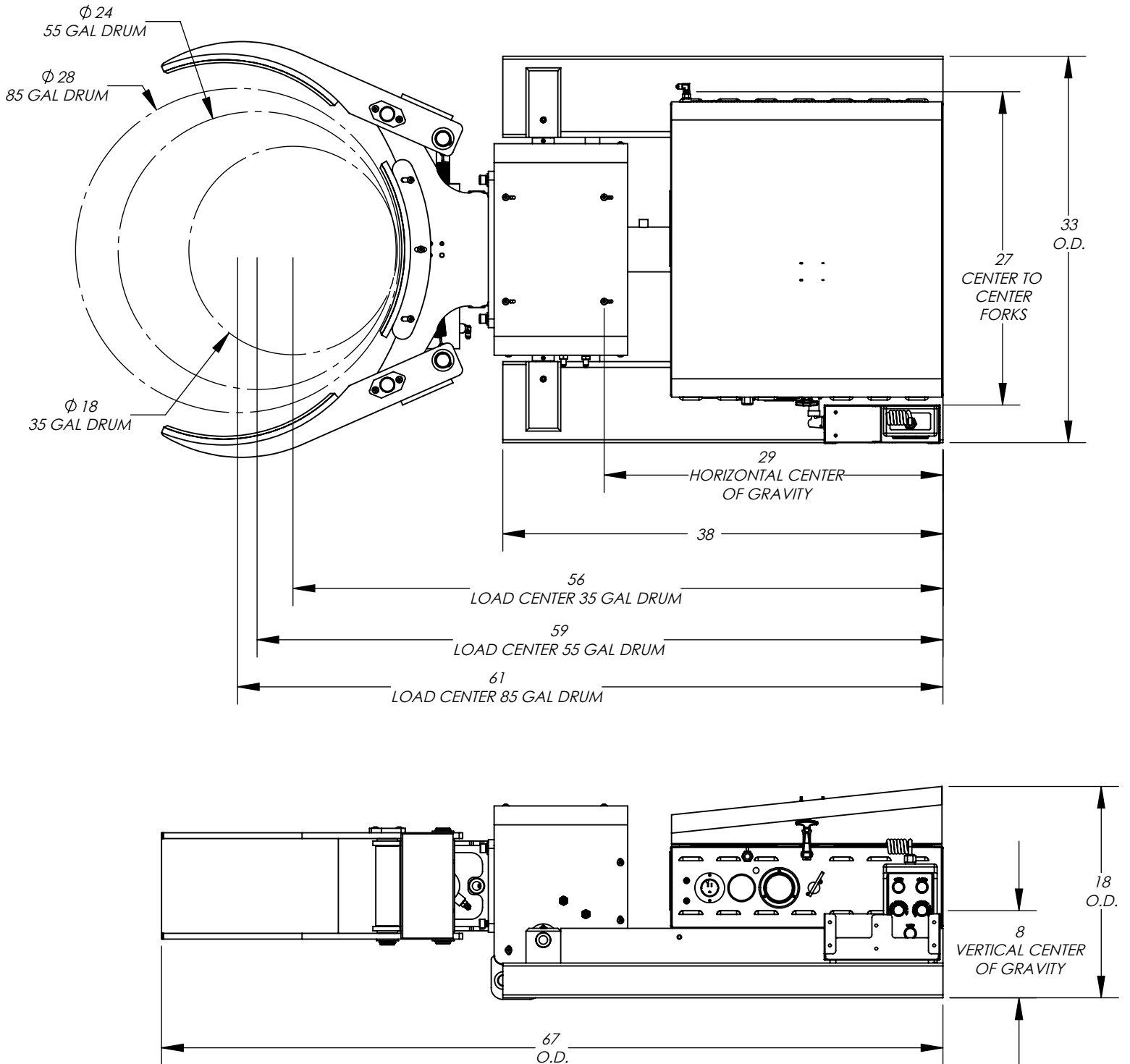

NOTES:

△ A : LOAD CAPACITY 2000LBS

△ B : WEIGHT 850

△ C : CONTACT LIFT TRUCK MANUFACTURER FOR DOWNRATED CAPACITY

Warranty and Limitation of Liability

Valley Craft products are warranted for a period of one (1) year from date of shipment from Valley Craft's plant to be free from defects in material and workmanship under correct use, normal operation and proper application. However, parts of other than Valley Craft manufacture are subject ONLY to the original manufacturer's warranty. Valley Craft's obligation under warranty shall be limited to repair or exchange, at Valley Craft's option, FOB origin factory, of any Valley Craft product or part which proves to be defective as provided herein. Valley Craft reserves the right to either inspect the product at Buyer's location, or require it to be returned to the factory for inspection. The warranty contained herein does not extend to goods damaged, or subject to accident, abuse or misuse after shipment from Valley Craft's factory, nor to goods altered or repaired by anyone other than an authorized Valley Craft representative.

Buyer or user shall not alter, modify or use a Valley Craft product for anything other than its intended function. Valley Craft shall not in any way be responsible for the consequences of any such alteration, modification or misuse.

VALLEY CRAFT MAKES NO EXPRESS WARRANTIES OTHER THAN THOSE WHICH ARE SPECIFICALLY DESCRIBED HEREIN. Any description of the goods sold hereunder, including any references to Buyer's specifications and any descriptions in catalogs, circulars and other written material published by Valley Craft, is for the sole purpose of identifying such goods and shall not create an express warranty that the goods shall conform to such descriptions.

THIS WARRANTY IS EXPRESSLY IN LIEU OF ALL OTHER WARRANTIES, EXPRESS OR IMPLIED. THERE ARE NO IMPLIED WARRANTIES OF MERCHANTABILITY OR FITNESS FOR A PARTICULAR PURPOSE. THIS WARRANTY STATES VALLEY CRAFT'S ENTIRE AND EXCLUSIVE LIABILITY AND BUYER'S EXCLUSIVE REMEDY FOR ANY CLAIM OR DAMAGES IN CONNECTION WITH VALLEY CRAFT PRODUCTS, THEIR DESIGN. SUITABILITY FOR USE, INSTALLATION OR OPERATION OR FOR ANY CLAIMED DEFECTS. VALLEY CRAFT WILL IN NO EVENT BE LIABLE FOR INCIDENTAL OR CONSEQUENTIAL DAMAGES WHATSOEVER, NOR FOR ANY SUM IN EXCESS OF THE PRICE RECEIVED FOR THE GOODS FOR WHICH LIABILITY IS CLAIMED.

Technical Assistance/Warranty Procedure

What's Covered:

- Parts and Labor to correct manufacturer's defect within one year of purchase.
- Freight Cost

What's Not:

- Normal wear items (seal kits, bearings, tires, etc.)

What Voids the Warranty:

- Dirt/Grime that directly causes malfunction of product
- Abuse (i.e. Overloading, damaged, not properly maintained, etc.)
- Product altered by customer

*See "Items not Under Warranty" below for items that have the warranty voided.

Items Under Warranty (less than one year old):

- Warranty replacement parts are provided only when the problem can be identified with near certainty. If not, the customer will return item to Valley Craft, freight collect, for troubleshooting and/or repair. When repaired, product will be returned to customer,



Valley Craft is a modern metals fabricating manufacturer specializing in material handling, storage and specialized solutions designed with safety and usability in mind, and the simplification of even the heaviest of workloads. Since developing the first hand truck with a brake in 1952, Valley Craft has been a true pioneer in safety-conscious material handling and solution-driven products. Our commitment to continuous improvement in a Lean Manufacturing environment results in safe, functional, quality equipment at affordable prices.

Valley Craft, Inc.

2001 South Highway 61
Lake City, Minnesota 55041 U.S.A.

Phone: (651) 345-3386

Toll Free: (800) 328-1480

Fax: (651) 345-3606

E-Mail: customer@valleycraft.com

Web: valleycraft.com • ovation-solutions.com
