

SOLUTIONS TO SIMPLIFY YOUR WORKLOAD  
Material Handling, Storage & Specialized Equipment

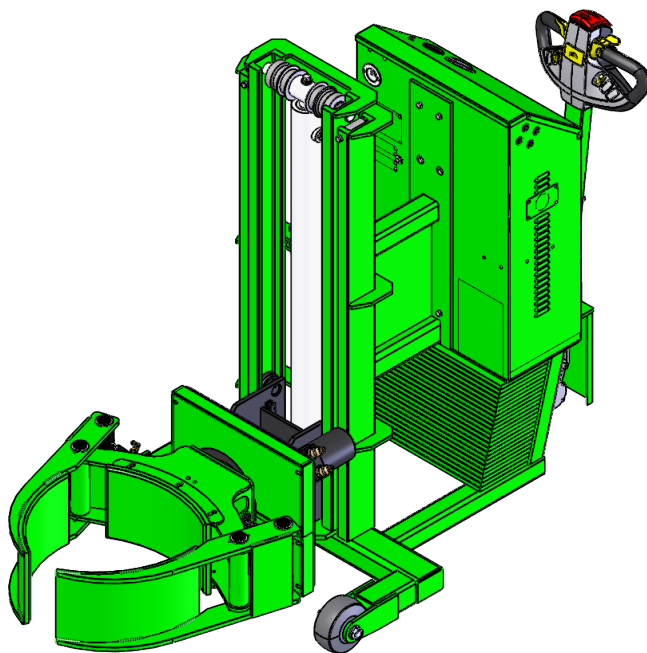

# F89529 ROTOGRIP-UG3/PD/CW/TM



## **Notice to Purchaser**

All statements, technical information, and recommendations related to Valley Craft's products are based on information believed to be reliable, but the accuracy or completeness is not guaranteed. Before using this product, you must determine if it is suitable for your intended application or situation. You assume all risks and liability associated with such use or implementation.

## **Product Testing**

We perform vigorous in-house safety and durability testing to ensure that the performance of our products meets the demands of the workplace. We also expect the same from manufacturers who supply components for our products. We do this to ensure that Valley Craft is a name that our customers trust and associate with quality.

## **Publication Revision Notice**

Following is a history of changes to this publication, including the current revision.

Previously Updated: 11/2021

Last Updated: 12/2021

## **Copyright Notice**

© Valley Craft, Inc. All rights reserved. No part of this publication may be reproduced, photocopied, stored on a retrieval system, or transmitted without the express written consent of Valley Craft.

## **Trademarks**

The Valley Craft logo is a Valley Craft Trademark. All other company or product names are trademarks or registered trademarks of their respective owners. Use of a term in this document should not be regarded as affecting the validity of any trademark or service mark.

**■ Table of Contents**

---

|  |            |
|--|------------|
| <b>Safety</b> .....                          | <b>4-6</b> |
| • Safety Overview .....                      | 4          |
| • Safety Message Conventions.....            | 5          |
| • Material Safety Data .....                 | 6          |
| <b>Unpacking and Assembly</b> .....          | <b>7</b>   |
| • Receiving and Inspection .....             | 7          |
| <b>Operation</b> .....                       | <b>7</b>   |
| • Initial Startup Procedures .....           | 7          |
| • Tiller-Head .....                          | 8          |
| • Adjusting Clamp Pressure .....             | 9          |
| • Battery Discharge Guage .....              | 10         |
| • Charging Batteries.....                    | 11         |
| <b>Maintenance and Adjustments</b> .....     | <b>12</b>  |
| • Maintenance and Adjustment Procedures..... | 12         |
| <b>Troubleshooting</b> .....                 | <b>13</b>  |
| • Trouble Shooting Procedures.....           | 13         |
| <b>Replacement</b> .....                     | <b>14</b>  |
| • Replacement Procedures .....               | 14         |
| <b>Parts List</b> .....                      | <b>15</b>  |
| • F89529 ASSY .....                          | 15         |
| • F89529 BOM .....                           | 16         |
| • F60552A3 ASSY/BOM .....                    | 17         |
| • F60550A1 ASSY/BOM .....                    | 18         |
| • F60202A3 ASSY/BOM .....                    | 19         |
| <b>Equipment Drawings</b> .....              | <b>20</b>  |
| • Hydraulic .....                            | 20         |
| • Electrical.....                            | 21         |
| <b>Warranty</b> .....                        | <b>22</b>  |
| • Warranty.....                              | 22         |

## Safety

*Read and understand all safety information and become familiar with all safety symbols contained in this section before moving, operating or performing maintenance on this equipment.*

### ■ Safety Overview

The following general safety precautions must be observed during all phases of operation, service, and repair of this equipment. Failure to comply with these precautions or with specific safety messages elsewhere in this manual may impair the protection provided by the equipment. Such noncompliance would also violate safety standards of design, manufacture, and intended use of the instrument.

- Observe all safety signs posted in your facility.
- Observe warnings, cautions, handling information, storage requirements and other information on all container labels.
- Wear safety glasses with side shields.
- Wear the proper protective clothing, gloves and other protective equipment before handling any chemicals.
- Group the containers for the move by Hazard Class. Do not move acids with toxics, or oxidizers.
- Use maximum care and good judgment in preventing accidents and injuries and seeking first aid.
- Report unsafe conditions, equipment, practices, and on-job injuries.
- Understand your supervisor's instructions. Ask questions if you do not know how to do the job safely.
- Do not engage in tasks which you believe might be unsafe without consulting your supervisor.
- Clean up the work area and equipment upon job completion.
- Before you start work on any electrical system or circuit, check all power sources to ensure that the system or circuit is de-energized.
- Know the hazardous or potentially hazardous substances you work with or are present in your work area. Review Material Safety Data Sheets (MSDS) on these substances, or contact your supervisor.

## ■ Safety Message Conventions

Three types of safety notices may be contained in this manual: **Danger**, **Warning** and **Caution** notices. These notices precede the procedural step or portion of text that presents the safety hazard.



### **DANGER**

---

- **DANGER** indicates an imminently hazardous situation which, if not avoided, will result in death or serious injury. This signal word is to be limited to the most extreme situations.
- 



### **WARNING**

---

- **WARNING** indicates a potentially hazardous situation which, if not avoided, could result in death or serious injury.
- 



### **CAUTION**

---

- **CAUTION** indicates a potentially hazardous situation which, if not avoided, may result in minor or moderate injury. It may also be used to alert against unsafe practices
-

## ■ Material Safety Data Sheets (MSDS)

A Material Safety Data Sheet (MSDS) provides information on the safe use, handling and potential hazards of a product. This information assists with the proper response in the event of an emergency.

Valley Craft maintains material safety data sheets (MSDSs) on all our products. You are urged to obtain copies of the relevant MSDSs before using our products to protect yourself and others against any known health or safety hazards described in these MSDSs. Valley Craft strives to make safety a top priority. Do not hesitate to contact us to discuss any safety aspects of our products.

**The relevant MSDS codes for Valley Craft products are listed below.**

- [www.conocophillips.com](http://www.conocophillips.com)  
Super ATF Transmission Oil, MSDS Code 778846  
Super-Sta Grease, MSDS Code 775440
- [www.batteriesplus.com](http://www.batteriesplus.com)  
Sealed Lead Acid Battery  
SLA for English version  
SLA Sp for the Spanish version
- [Paint](#)  
Contact Valley Craft Customer Service at 1-800-328-1480 or on the Web at [customerservice@valleycraft.com](mailto:customerservice@valleycraft.com)

## ■ Additional Safety Information

As with any mechanical device, care must be taken during the installation, operation, and maintenance of the device in order to realize the maximum benefit from its ownership.

**Note:** All personnel involved in the use and maintenance of this device should be thoroughly familiar with the information contained in this manual. Furthermore, it is recommended that all personnel be given adequate instruction and a sufficient period of training in its actual use to insure safety of personnel and proper care of the equipment. It is suggested that the units be initially operated empty until becoming familiar with operation of this unit.

## ■ Receiving and Inspecting

When unpacking the equipment, inspect for signs of damage or mishandling. If damage is noted, file a damage claim with the carrier within 24 hours and call Valley Craft at 1-800-328-1480. Do not attempt to use the equipment.

Compare the contents of the shipment with the bill of lading. Report any missing items to the carrier and to Valley Craft immediately.

## ■ Operating Procedures

Only authorized and trained personnel should be permitted to use this equipment. Improper use may result in personal injury and/or damaged to the unit and surrounding property.

- **Before operating the unit for the first time, remove the red plastic plug in the hydraulic reservoir and replace with the black breather cap supplied with the unit.**

1. Turn portable lift on.
2. Position the portable lift with the rear saddle of the jaws tight to the drum.
3. Center the Jaws vertically around the drum by depressing and holding the (up/down) switch until reaching the desired position. Grip drum in center at all times.
4. Clamp the drum by depressing and holding the (clamp/unclamp) to the clamp positions while simultaneously depressing the “safe” push button. The clamp/unclamp functions are wired to require 2 hand operations to avoid accidental release of a suspended drum.
5. Once clamped, the drum may be raised or lowered to the desired height by turning and holding the (up/down) switch.
6. After reaching the desired height, the drum may be rotated by turning and holding the rotate (left/right) switch in the desired direction.

## ■ Operating Procedures Tiller-Head

### Operating the Tiller-head

1. Turn key switch on.
2. Wig wag switch controls direction of drive wheel. Push wig wag forward for wheel to drive forward. Opposite for reverse.
3. Red belly button switch stops unit in reverse if operator is pinched between wall and switch.
4. Horn pushbutton activates audible noise to alert coworkers of a moving piece of equipment.
5. Hydraulic functions are actuated by rocker switches.
6. To operate clamp/unclamp the “safe” button must be depressed.





## ■ Adjusting Clamp Pressure

### To adjust clamp pressure:

1. Remove rear cover on control box.
2. Use  $\frac{3}{4}$ " open end wrench to loosen the jam nut on the pressure port stem.
3. Use an Allen wrench to adjust clamp pressure by turning the stem.
  - Turn the stem clockwise to increase pressure
  - Turn the stem counter-clockwise to decrease pressure

**Note: Every drum or container is different. It may not be possible to find one pressure setting that will work for all applications without re-adjusting. It is the customer's responsibility to determine a safe clamp pressure for their specific application.**

4. Every lift should be performed with as high of a clamp pressure as possible without damaging the container.

**Note: If the container is not rigid enough to resist the clamp pressure needed to safely lift it, do NOT attempt moving or dumping it. Please contact Valley Craft to see if an alternative clamp method would work better for your specific application.**

5. Once correct clamp pressure has been found, re-tighten the jam nut onto the stem.
6. Replace the back cover and return the unit to service.

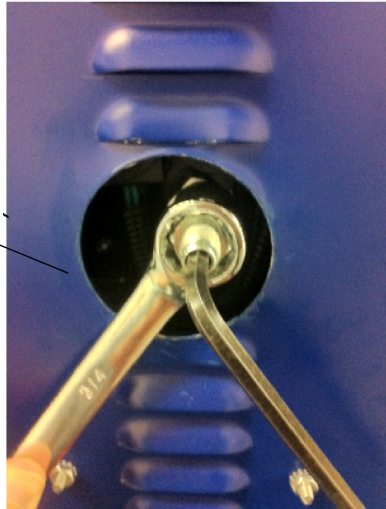
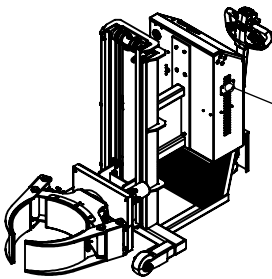

Note: Wrench shown outside the cabinet for clarity. Your machine may require removal of the back panel to loosen the jam nut and adjust pressure.

## ■ Operating Procedures Z20836A7 GAUGE-BATTERY DISCHARGE



### Configuring Your Gauge

Access to these operations is sequential in this order. Adjustments of the following functions can be performed in the configuration mode.

1. Time-of-Day Clock

During configuration, the right button is used to increment. The left button is used to

1. Enter a selection
2. Advance to the next configurable item

If no change is desired to a specific gauge function, continue to press the left button until the next desired function is reached. The time-of-day clock is entered by setting the hours digits between 01 and 12, then 'minutes' digits between 00 and 59.

### Setting the Time-of-Day Clock

The display will flash the two 'hours' digits. Press the right button to increment by one hour, or hold the button to increment continuously. When the desired number of hours is reached, press the left button once. The display will flash the two 'minutes' digits. Press the right button to increment by one minute or hold the button to increment continuously. When the desired number of minutes is reached, press the left button once.

### Configuration Notes

The gauge remains in configuration mode for 30 seconds without input from the user. When configuring each function you must enter in all data for that function for it to be saved. If incomplete data is entered for a function and the programming mode is timed out (after 30 seconds of no input received by the gauge), the gauge will revert back to what was previously stored for that item.

### Exiting Configuration Mode

The configuration mode can be exited in three ways?

1. Press and hold the left button for three seconds.
2. Leave buttons untouched for 30 seconds.
3. Press the left button after selecting the last (right) digit of the last function available.

### Toggle Display Functions

Press the left button to sequentially toggle between the three numeric gauge functions (time-of-day clock, maintenance hours, total hours).

### LCD Icons

1. Hourglass Icon – Turned on (not blinking) to indicate that an hour meter is displayed in the numeric display. Flashes to indicate hour meter accumulation.
2. Battery Icon – Turned on (not blinking) to indicate function. It flashes when a low condition is detected.
3. Colon – Flashes to indicate that the time-of-day clock is being displayed in the numeric display and that time is counting-up.
4. Decimal Point – To indicate 1/10 of a volt for the BDI profile.
5. Percent – Indicates remaining percentage of interval or level.

### Troubleshooting

| Problem                 | Possible Causes   |
|-------------------------|---|
| No display              | Terminals not connected<br>Improper voltage   |
| Stays at full           | Instrument voltage does not match battery voltage<br>V+ connected to wrong terminal                                       |
| Will not reset          | Instrument voltage does not match battery voltage<br>Battery not fully charged<br>Defective battery                       |
| Resets without charging | Not connected to battery terminal   |
| Empty too soon          | V+ connected to wrong terminal<br>Instrument voltage does not match battery voltage<br>Terminals not connected to battery |
| Cannot configure        | No power to the setup enable pin  |
|                         |   |

## ■ Charging Batteries

1. Always turn the key to the “off” position when unit is not in use.
2. To charge your battery, plug a grounded extension cord into the built-in receptacle in the Control Box and an outlet (see below).
3. The battery will charge automatically after the charger is plugged in and can be left unattended.
  - Batteries will generally require equal charging to work time.
4. Keep the charger plugged in to maintain a full battery level when the unit is not being used.

### NOTES:

- See charger **MANUAL** for **SAFETY PRECAUTIONS** and charger **TROUBLESHOOTING**.
- **DO NOT USE BATTERIES UNTIL THEY ARE TOTALLY DISCHARGED.**
  - i. Doing so may damage your battery.
  - ii. For maximum battery life, your unit is equipped with a charger that collects information from the battery and adjusts the current and voltage accordingly. If your battery voltage drops below a certain threshold the charger will not charge the battery.
- If the battery becomes discharged and won't charge by ordinary means, a suggested solution is to “trick” the charger into reading a higher voltage from the battery. To do this connect a second, well-charged battery (12.4 volts or greater) in parallel with the dead battery-positive to positive, negative to negative. Then plug in your charger and charge the combination until the dead battery has enough voltage to enable being charged by itself.

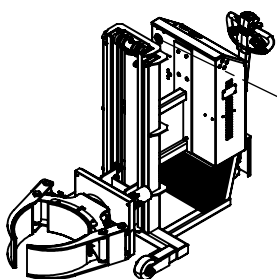

## Maintenance and Adjustments

### ■ Maintenance and Adjustment Procedures

To keep this unit operating properly, timely maintenance and adjustments are required. These procedures should be performed only by qualified personnel who are familiar with the equipment.

Maintenance and adjustment procedures are shown in Table 1.

*Table 1. Maintenance and Adjustment Procedures*

| Component            | Frequency         | Operation        | Procedure   |
|----------------------|-------------------|------------------|---|
| Wheels               | Daily             | Visually Inspect | Check the wheels to ensure they are not damaged or loose.   |
| Lift Chain           | Daily             | Visually Inspect | Inspect the roller chain and mounts for any sign of damage or wear. Replace as required.  |
| Batteries            | Daily             | Visually Inspect | Inspect batteries to ensure they are fully charged and free from damage   |
| Front clamp section  | Weekly            | Grease           | Use a grease gun to apply grease applicable zerks.  |
| Front rotate section | Weekly            | Grease           | Use a grease gun to apply grease to the zerk on the Rotate Sprocket.  |
| Hydraulic Fluid      | Quarterly         | Check level      | Remove the back panel of the control box and ensure the hydraulic reservoir is approximately $\frac{3}{4}$ full. Re-fill if required. |
|                      | Yearly            | Replace fluid    | Remove hydraulic reservoir, clean and refill with new hydraulic fluid.  |
| Hydraulic System     | At Start of Shift | Operate          | Fully extend lift cylinder to purge oil from rod end of the cylinder  |

## Troubleshooting

### Troubleshooting Procedures

This unit is a quality product that is designed and manufactured to provide prolonged service under normal operating conditions. If troubleshooting is required, it should be performed only by qualified personnel who are familiar with the equipment.

| Issue   | Possible Cause  | Procedure  |
|---|---|--|
| Unit won't power on.                                | Dead batteries<br>Bad Connection                                    | Plug unit in and allow it to charge fully.<br>Have electrician trace power wires to find faulty connection.  |
| Unit has power but hydraulic pump motor wont run.   | Bad connection or blown fuse.<br>Faulty start relay<br>Faulty Motor | Have electrician ensure that power is being supplied all the way to the motor.<br>Ensure the start relay inside the motor electrical enclosure is functioning properly<br>Relay is supplying power to drive motor but still doesn't run. Contact Valley Craft for a replacement.                                     |
| Hydraulic Motor runs but one function doesn't work. | Bad electrical connection.<br>Faulty switch<br>Faulty Solenoid      | Ensure the solenoid for the desired function is receiving power. Repair connection as required.<br>If power is stopping at a switch, check connections and contact Valley Craft for a replacement if required.<br>If solenoid is receiving required power and doesn't shift, contact Valley Craft for a replacement. |
| Everything works except for rotate.                 | Blown seal in rotary union  | Remove hydraulic Hoses supplying rotary union and run the briefly into a bucket to ensure fluid is being supplied.<br><br>If fluid is being supplied to the rotary union but it still doesn't rotate correctly, Contact Valley Craft customer service for assistance.  |

## Replacement

### ■ Replacement Procedures

Occasionally, it will be necessary to replace a part that has been Damaged or worn. Many parts on this product are replaceable. If Replacement of a part is required, it should be performed only by Qualified personnel who are familiar with the equipment.

See Sheet X for available replacement parts. Identify the part number you need. Contact Valley Craft Customer Service at 1-800-328-1480 or on the Web at [customerservice@valleycraft.com](mailto:customerservice@valleycraft.com).

Information required when contacting Valley Craft:

- A. Company name and address
- B. Contact persons name
- C. Telephone number
- D. E-Mail address
- E. Model Number
- F. Date of manufacture
- G. Part number(s) of part(s) to be ordered

The model number and date of manufacture is stamped on a metal tag located on the mast of the unit.

F89529  
ROTOGRIP-UG3/PD/CW/TM

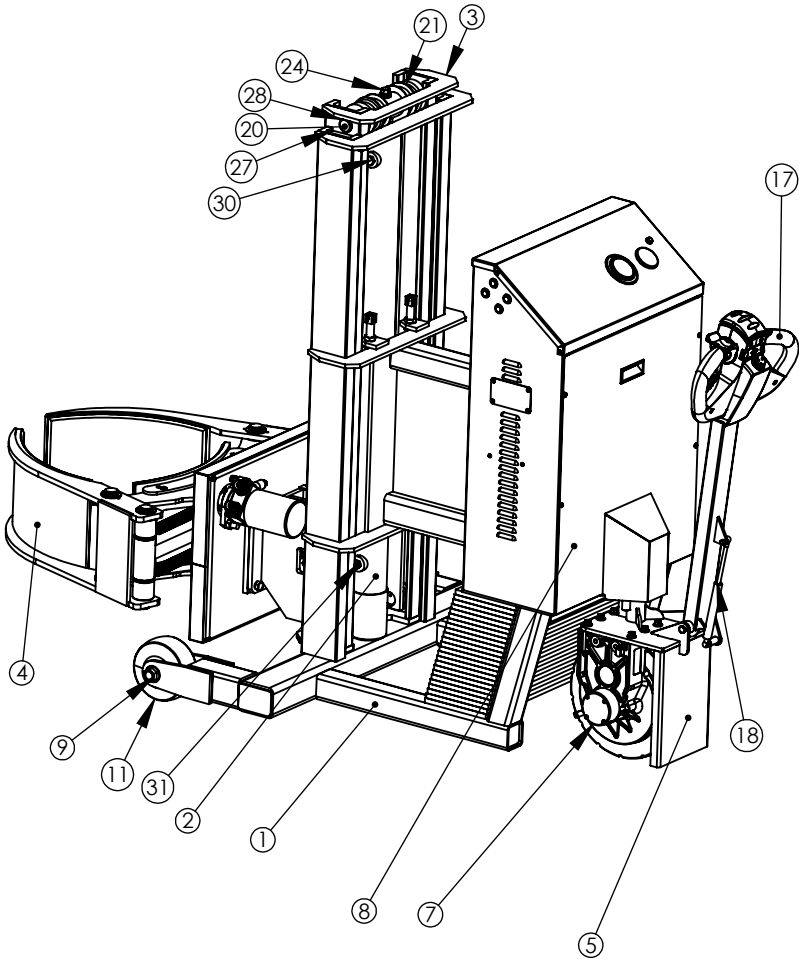

ROTOGRIP-UG3/PD/CW/TM

F89529

ROTOGRIP-UG3/PD/CW/TM

| ITEM NO. | PART NUMBER | DESCRIPTION                       | QTY. |
|----------|-------------|-----------------------------------|------|
| 1        | F60598A9    | CW PD WLDMT-TELE MAST             | 1    |
| 2        | Z20876A1    | CYL 2-1/2X1-1/2X36                | 1    |
| 3        | F60601A2    | OUTSIDE MAST WELDMENT TM          | 1    |
| 4        | F60599A0    | CARRIAGE N CLAMP/PL PD<br>UG3 TM  | 1    |
| 5        | F68097A4    | PIVOT WLDMT/POWER DRIVE           | 1    |
| 6        | Z20830A3    | BRG-BRZ-FLG 1.25X1.50X1.50        | 2    |
| 7        | Z20827A6    | WHL ASSY-12/PD                    | 1    |
| 8        | F60602A3    | PD CONTROL BOX ASSY TM            | 1    |
| 9        | Z60010A2    | S-HHC 3/4-10 X 5 FLANGE           | 2    |
| 10       | Z60011A1    | NUT-FLANGE 3/4-10 NYLOCK          | 2    |
| 11       | Z30793A7    | WHL-6 X 2-1/2 SE 2200CAP          | 2    |
| 12       | F68098A3    | TILLER WLDMT/POWER DRIVE          | 1    |
| 13       | Z10432A6    | BALL-STUD 5/16-18 UNC             | 2    |
| 14       | Z20828A5    | BRG-BRZ-FLG .63X.88X1.00          | 2    |
| 15       | Z20826A7    | RING-RTNG EXTERNAL 5/8            | 6    |
| 16       | F58422A4    | RD-.63/AXLE TILLER (KANBAN)       | 3    |
| 17       | Z20823A0    | TILLER HEAD/PD                    | 1    |
| 18       | Z20825A8    | SPRING-GAS/120LBS                 | 1    |
| 19       | F51639      | HEAD-CYLINDER TM                  | 1    |
| 20       | F51640      | HEAD-CYLINDER SHAFT TM            | 1    |
| 21       | F60605A6    | HYD HOSE/CHAIN SHEAVE<br>BRG ASSY | 2    |
| 22       | Z10546A2    | NUT-HEX JAM 5/8-18                | 4    |
| 23       | Z10579A6    | CHAIN ADJ/HI LEVEL<br>(KANBAN)    | 2    |
| 24       | Z10151A5    | S-HHC 1/2-13X3 GR 5               | 1    |
| 25       | Z10331A8    | WASHER-1/2 FLAT SAE               | 3    |
| 26       | Z10216A8    | WASHER-1/2 LOCK MD                | 1    |
| 27       | F60606A7    | GUIDE MAST ASSY TM                | 2    |
| 28       | Z10534A4    | RING-RTNG 1-1/4                   | 3    |
| 29       | Z20814A9    | GROMMET-<br>.75IDX1.13HOLEX.09TH  | 1    |
| 30       | Z20733A1    | BREATHER 6 SAE SINTERED           | 1    |
| 31       | Z20597A5    | FTG STR 6400-4-6-O                | 1    |
| 32       | Z10543A5    | PIN-COTTER 1/6X1/2                | 4    |
| 33       | Z30596A0    | PIN-CLEVIS 3/16X1                 | 4    |
| 34       | Z20813A0    | GROMMET-<br>.75IDX1.06HOLEX.25TH  | 2    |
| 35       | Z10202A4    | WASHER-3/8 FLAT SAE               | 10   |
| 36       | Z10214A0    | WASHER-3/8 LOCK MD                | 6    |
| 37       | Z10530A8    | S-HHC 3/8-16x1-1/4                | 10   |
| 38       | 98420A161   | RING-RTG 1-1/4                    | 2    |
| 39       | Z10500A7    | NUT-HEX KEPS 3/8-16               | 4    |



# ROTOGRIP-UG3/PD/CW/TM

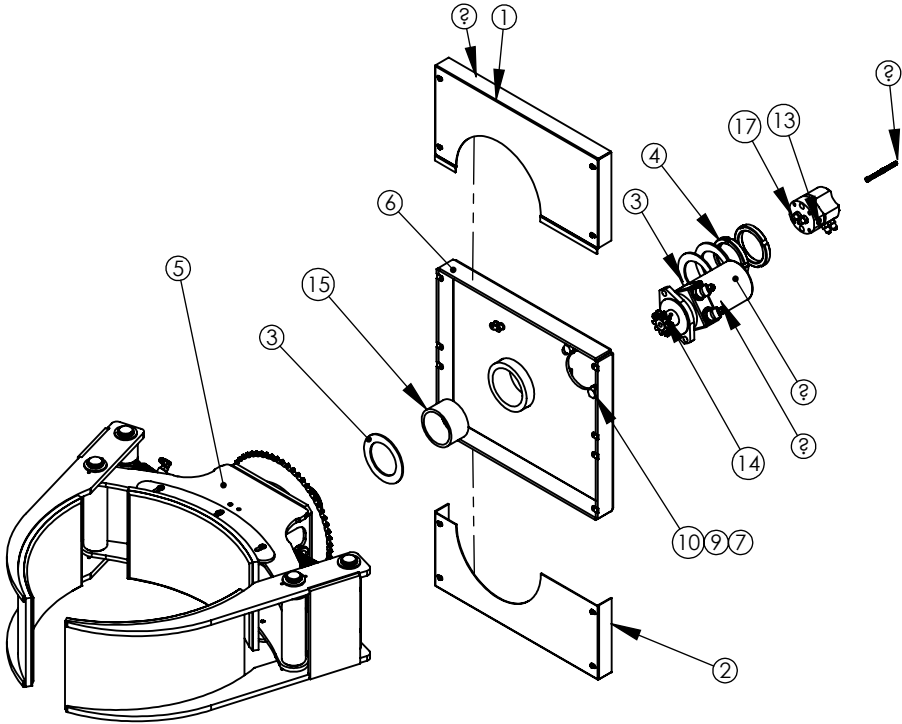

| ITEM NO. | PART NUMBER | DESCRIPTION                    | Default/QTY. |
|----------|-------------|--------------------------------|--------------|
| 1        | F57604      | TOP SPROCKET GUARD PL PD UG3   | 1            |
| 2        | F57605      | BTM SPROCKET GUARD PL PD UG3   | 1            |
| 3        | F51291      | NYLON SPACER 3IDX4.5ODX.125    | 2            |
| 4        | F51292      | ROTATE JAM NUT (KANBAN)        | 2            |
| 5        | F60550A1    | UG-JAW ASSY 15-30 PL PD        | 1            |
| 6        | F69418A4    | BACK SECT WLDMT/UG3 PL PD      | 1            |
| 7        | Z10048A2    | NUT-NYL NE 1/2-13              | 2            |
| 8        | Z10166A8    | S-HHTC #10-24X1/2              | 8            |
| 9        | Z10331A8    | WASHER-1/2 FLAT SAE            | 2            |
| 10       | Z10620A4    | S-HHC 1/2-13X2 GR 5            | 2            |
| 11       | Z20656A6    | MOTOR-HYD/SAE                  | 1            |
| 12       | Z20891A6    | FTG 45 6802-6-10 NWO           | 2            |
| 13       | Z20869A2    | VEKTEK ROTATOR 32-2242-03      | 1            |
| 14       | Z30400A2    | SPROCKET-SM W/SHS              | 1            |
| 15       | Z31607A8    | BRG-BRZ 3 IDX3.5ODX2" LONG     | 1            |
| 16       | F51484      | WASHER-4-1/2ODX3IDX3/16 (STK)  | 1            |
| 17       | Z20615A7    | FTG STR 6400-4-4-O             | 4            |
| 18       | F30197A5    | CHAIN-RS 50/43-1/2"            | 1            |
| 19       | Z11690A5    | S-SHC 1/4-20X1-1/2 GR8         | 2            |
| 20       | Z10200A6    | WASHER-1/4 FLAT USS            | 12           |
| 21       | Z10299A8    | WASHER-3/16 FLAT SAE           | 8            |
| 22       | Z10036A6    | NUT-HEX KEPS 5/16-18           | 1            |
| 23       | Z10128A5    | S-HHC 5/16-18X2-1/2 Z5 FULL TH | 1            |

# ROTOGRIP-UG3/PD/CW/TM

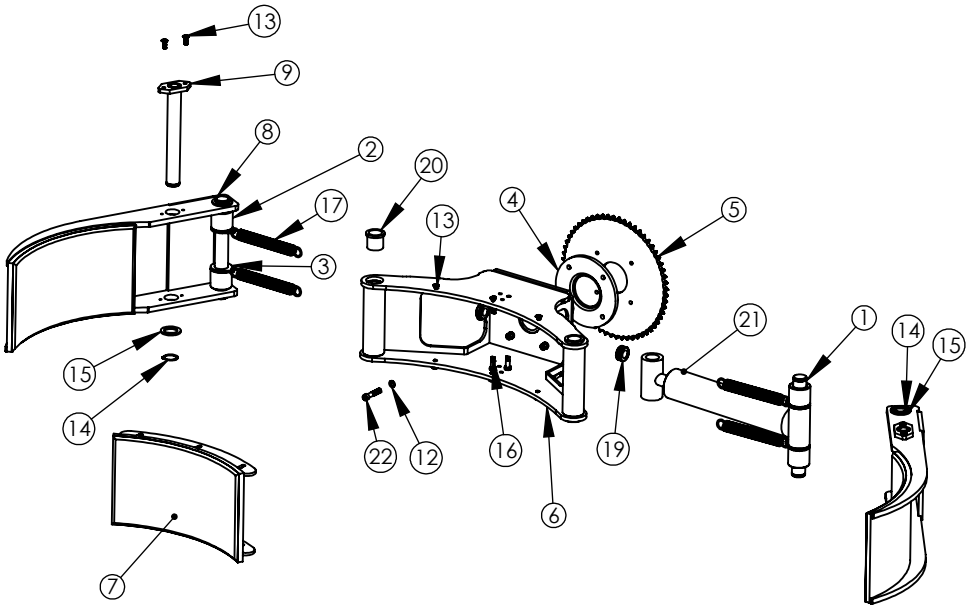

| ITEM NO. | PART NUMBER | DESCRIPTION                          | EXP VIEW/QTY. |
|----------|-------------|--------------------------------------|---------------|
| 1        | F50401      | CYL PIN 1.25 UG3 FRT SECT (KANBAN)   | 2             |
| 2        | F50435      | RD-2.00/UG3 JAW ASSY CYL SPCR        | 4             |
| 3        | F50438      | SHT-.19/UG3 JAW ASSY SPRG CLIP (STK) | 4             |
| 4        | F51279      | SPCR PLATE RD UG3 PL PD (STK)        | 1             |
| 5        | F51281      | SPROCKET-LRG BORE UG3 PL PD          | 1             |
| 6        | F60449A0    | ARM WLDMT UG PL PD UG3               | 1             |
| 7        | F68824A2    | UG-JAW-SADDLE WLDMT-15-30 (9") (STK) | 1             |
| 8        | F68825A3    | UG-JAW-WLDMT-18-28 (9") (STK)        | 2             |
| 9        | F68832A0    | UG-JAW-PIN WLDMT-20-35               | 2             |
| 10       | Z10026A8    | NUT-HEX JAM 3/8-16ZP                 | 4             |
| 11       | Z10201A5    | WASHER-5/16 FLAT USS                 | 4             |
| 12       | Z10214A0    | WASHER-3/8 LOCK MD                   | 4             |
| 13       | Z10438A0    | S-BHCS 1/4-20X3/4 BLK                | 10            |
| 14       | Z10534A4    | RING-RTNG 1-1/4                      | 6             |
| 15       | Z10592A2    | BUSH-MACH 1-1/4X10GA ZP              | 6             |
| 16       | Z11484A3    | CONNECTOR 3/8-16 SPRING              | 4             |
| 17       | Z11485A2    | SPRING-EXTENSION 1.00X.14X8.00       | 4             |
| 18       | Z20616A6    | FTG 90 6801-4-4 NWO                  | 2             |
| 19       | Z20813A0    | GROMMET-.75IDX1.06HOLEX.25TH         | 2             |
| 20       | Z20830A3    | BRG-BRZ-FLG 1.25X1.50X1.50           | 4             |
| 21       | Z20845A8    | CYL ASSY-UG3 CLAMP 1.13ROD (319392)  | 1             |
| 22       | Z11562A7    | S-SHC 3/8-16X2 ZP                    | 4             |

# ROTOGRIP-UG3/PD/CW/TM

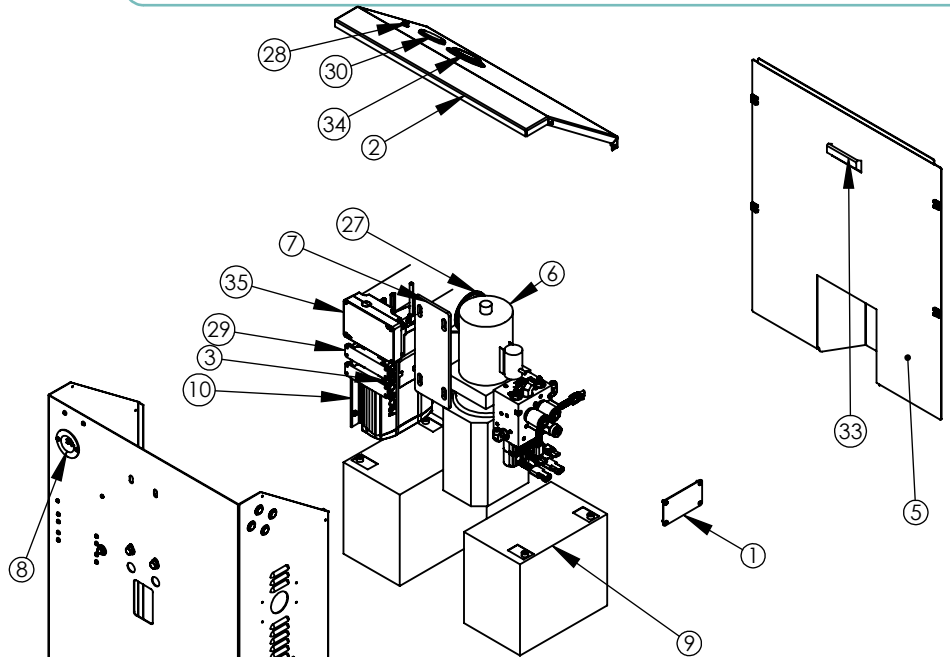

| ITEM NO. | PART NUMBER | DESCRIPTION   | QTY. |
|----------|-------------|---|------|
| 1        | F51398      | CVR-PD PRES GAUGE (Kanban)                                      | 1    |
| 2        | F51435      | TOP-CRIT BOX/PL PD IM   | 1    |
| 3        | F58408A6    | SHT-14G/FUSE JUMPER (KANBAN)                                    | 1    |
| 4        | F69417A3    | CONTROL BOX WELDMENT IM   | 1    |
| 5        | F69416A2    | CVR CNTR WLDMT/PD TELE  | 1    |
| 6        | F68007A8    | PP-6SOI/5PORT 24V   | 1    |
| 7        | F68096A5    | PUMP MNT WLDMT/POWER DRIVE                                      | 1    |
| 8        | Z00120A4    | PLUG-FLGD INLET 125V  | 1    |
| 9        | Z00172A5    | BATTERY-12V 80AH SEALED LEAD                                    | 2    |
| 10       | Z20362A2    | CHRG-BATTERY 12/24 120VAC                                       | 1    |
| 11       | Z10003A5    | NUT-HEX KEPS #4-40  | 3    |
| 12       | Z10036A6    | NUT-HEX KEPS 5/16-18  | 1    |
| 13       | Z10124A9    | S-HHC 5/16-18X1-1/4   | 1    |
| 14       | Z10132A9    | S-HHC 3/8-16X1  | 2    |
| 15       | Z10176A6    | S-RHM #10-24X1/2  | 14   |
| 16       | Z10201A5    | WASHER-5/16 FLAT USS  | 2    |
| 17       | Z10202A4    | WASHER-3/8 FLAT SAE   | 6    |
| 18       | Z10214A0    | WASHER-3/8 LOCK MD  | 2    |
| 19       | Z10382A6    | NUT-HEX KEPS #8-32 ZP   | 6    |
| 20       | Z10385A3    | S-PTHM #8x3/8 LG  | 10   |
| 21       | Z10391A5    | NUT-HEX KEPS #10-24   | 14   |
| 22       | Z10463A8    | S-PTHM #8-32x3/8  | 4    |
| 23       | Z10500A7    | NUT-HEX KEPS 3/8-16   | 2    |
| 24       | Z10530A8    | S-HHC 3/8-16x1-1/4  | 2    |
| 25       | Z10572A2    | S-RHM # 8-32X1-1/2  | 2    |
| 26       | Z11548A1    | S-FHM #4-40X3/8 ZP  | 3    |
| 27       | Z20815A8    | HORN-24V  | 1    |
| 28       | Z20817A6    | LIGHT-INDICATOR LED GRN 24V                                     | 1    |
| 29       | Z20820A3    | FUSE-HLDR ANL   | 2    |
| 30       | Z20836A7    | GAUGE-BATTERY DISCHARGE   | 1    |
| 31       | Z20839A4    | FUSE-ANL  | 2    |
| 32       | Z20849A3    | FIG 90 2502-4-4   | 1    |
| 33       | Z30415A5    | HDL PCKT PULL PLST 3.25X1.41                                    | 1    |
| 34       | Z84909A1    | GAUGE-PRESSURE 0-3K PSIG CFPT-210E**3000PSI 2.5 GLY FLG/PNL MNT | 1    |
| 35       | Z20913A8    | CONTROLLER/PD CURTIS 1226 (PROGRAMMED)                          | 1    |
| 36       | Z11701A6    | RETAINER 1/4 TURN   | 4    |
| 37       | Z11699A4    | EJECTOR SPRING  | 4    |
| 38       | Z11700A5    | PUSH-ON RETAINER  | 4    |
| 39       | Z11698A3    | CLIP ON RETAINER  | 4    |
| 40       | 9750K22     | PLUG-HOLE .5  | 4    |
| 41       | 90074A101   | SFHC-S-M5-0.8X10MM  | 4    |

# ROTOGRIP-UG3/PD/CW/TM

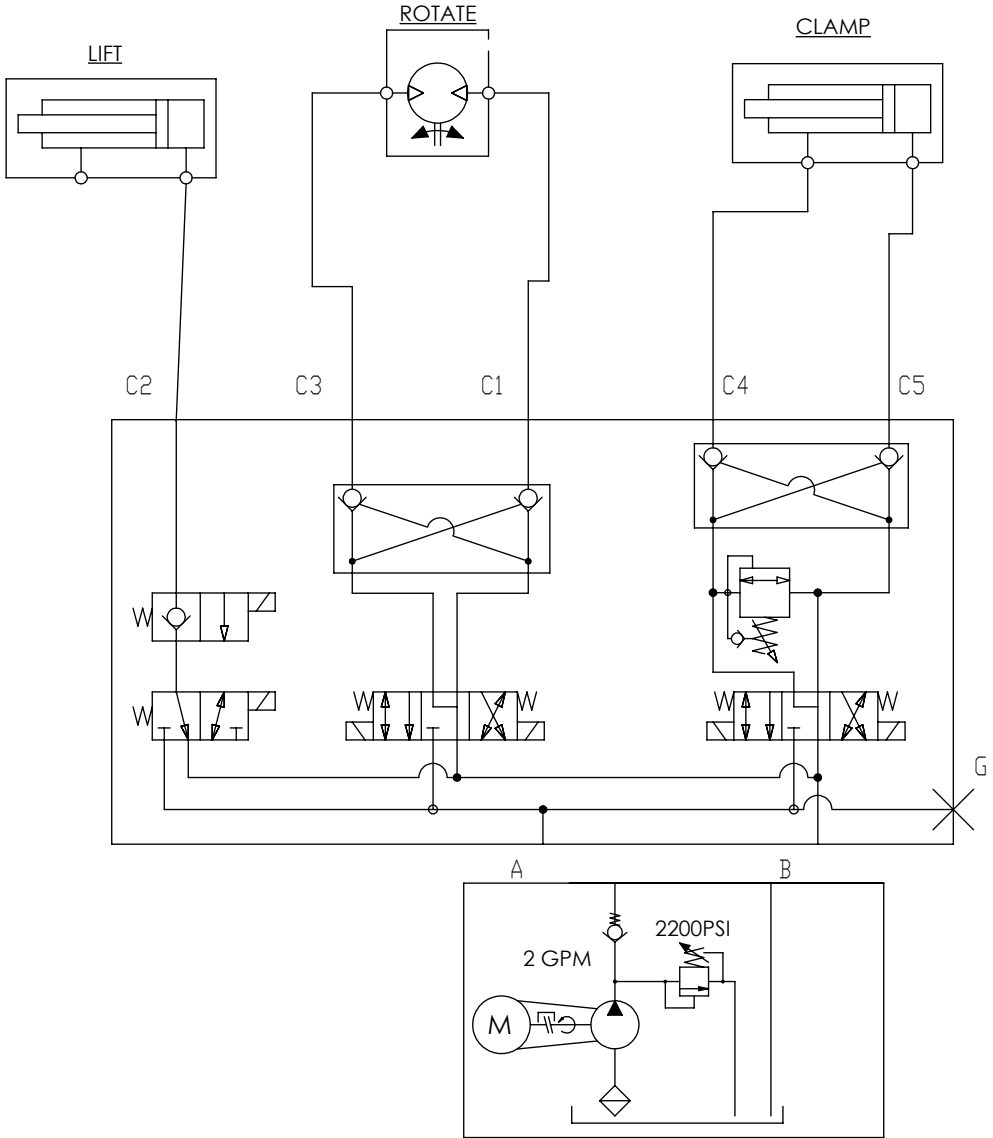



## Warranty and Limitation of Liability

Valley Craft products are warranted for a period of one (1) year from date of shipment from Valley Craft's plant to be free from defects in material and workmanship under correct use, normal operation and proper application. However, parts of other than Valley Craft manufacture are subject ONLY to the original manufacturer's warranty. Valley Craft's obligation under warranty shall be limited to repair or exchange, at Valley Craft's option, FOB origin factory, of any Valley Craft product or part which proves to be defective as provided herein. Valley Craft reserves the right to either inspect the product at Buyer's location, or require it to be returned to the factory for inspection. The warranty contained herein does not extend to goods damaged, or subject to accident, abuse or misuse after shipment from Valley Craft's factory, nor to goods altered or repaired by anyone other than an authorized Valley Craft representative.

Buyer or user shall not alter, modify or use a Valley Craft product for anything other than its intended function. Valley Craft shall not in any way be responsible for the consequences of any such alteration, modification or misuse.

VALLEY CRAFT MAKES NO EXPRESS WARRANTIES OTHER THAN THOSE WHICH ARE SPECIFICALLY DESCRIBED HEREIN. Any description of the goods sold hereunder, including any references to Buyer's specifications and any descriptions in catalogs, circulars and other written material published by Valley Craft, is for the sole purpose of identifying such goods and shall not create an express warranty that the goods shall conform to such descriptions.

THIS WARRANTY IS EXPRESSLY IN LIEU OF ALL OTHER WARRANTIES, EXPRESS OR IMPLIED. THERE ARE NO IMPLIED WARRANTIES OF MERCHANTABILITY OR FITNESS FOR A PARTICULAR PURPOSE. THIS WARRANTY STATES VALLEY CRAFT'S ENTIRE AND EXCLUSIVE LIABILITY AND BUYER'S EXCLUSIVE REMEDY FOR ANY CLAIM OR DAMAGES IN CONNECTION WITH VALLEY CRAFT PRODUCTS, THEIR DESIGN. SUITABILITY FOR USE, INSTALLATION OR OPERATION OR FOR ANY CLAIMED DEFECTS. VALLEY CRAFT WILL IN NO EVENT BE LIABLE FOR INCIDENTAL OR CONSEQUENTIAL DAMAGES WHATSOEVER, NOR FOR ANY SUM IN EXCESS OF THE PRICE RECEIVED FOR THE GOODS FOR WHICH LIABILITY IS CLAIMED.

## Technical Assistance/Warranty Procedure

### What's Covered:

- Parts and Labor to correct manufacturer's defect within one year of purchase.
- Freight Cost

### What's Not:

- Normal wear items (seal kits, bearings, tires, etc.)

### What Voids the Warranty:

- Dirt/Grime that directly causes malfunction of product
- Abuse (i.e. Overloading, damaged, not properly maintained, etc.)
- Product altered by customer

\*See "Items not Under Warranty" below for items that have the warranty voided.

### Items Under Warranty (less than one year old):

- Warranty replacement parts are provided only when the problem can be identified with near certainty. If not, the customer will return item to Valley Craft, freight collect, for troubleshooting and/or repair. When repaired, product will be returned to customer,



Valley Craft is a modern metals fabricating manufacturer specializing in material handling, storage and specialized solutions designed with safety and usability in mind, and the simplification of even the heaviest of workloads. Since developing the first hand truck with a brake in 1952, Valley Craft has been a true pioneer in safety-conscious material handling and solution-driven products. Our commitment to continuous improvement in a Lean Manufacturing environment results in safe, functional, quality equipment at affordable prices.

**Valley Craft Industries, Inc.**

2001 South Highway 61  
Lake City, MN 55041 U.S.A.

**Phone:** (651) 345-3386

**Fax:** (651) 345-6535

**E-Mail:** [customerservice@valleycraft.com](mailto:customerservice@valleycraft.com)

**Website:** [valleycraft.com](http://valleycraft.com)