

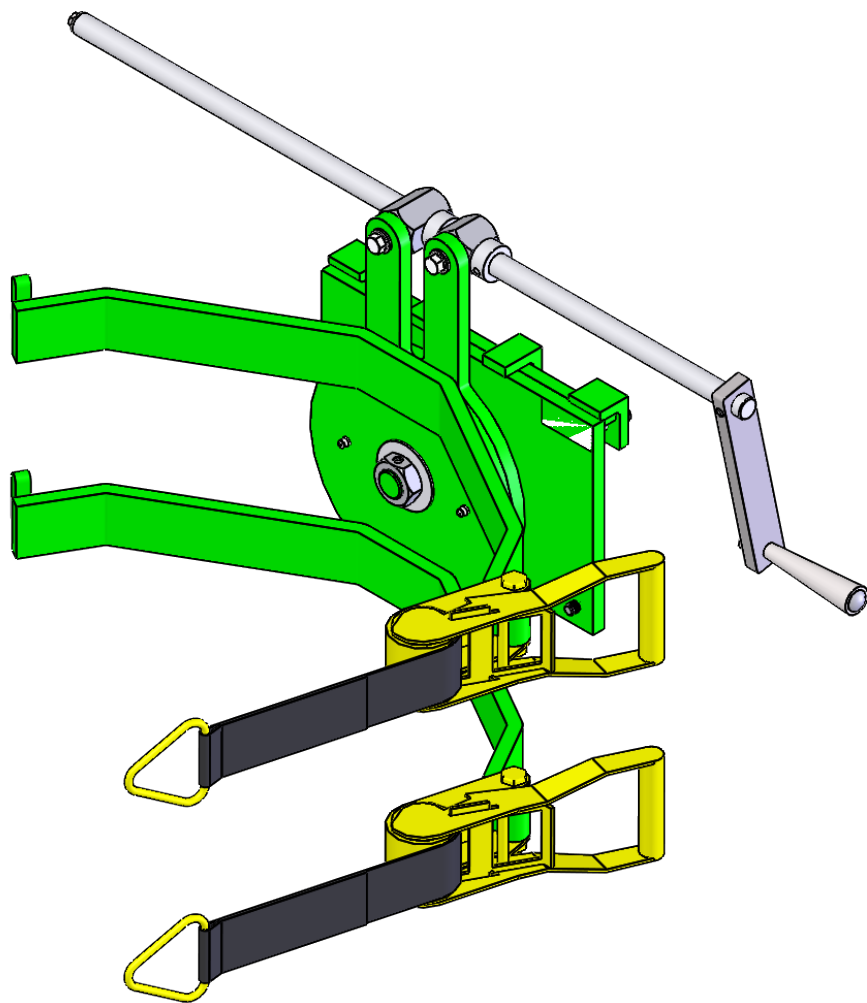

DRM TILT UNIT F89409A5



Notice to Purchaser

All statements, technical information, and recommendations related to Valley Craft's products are based on information believed to be reliable, but the accuracy or completeness is not guaranteed. Before using this product, you must determine if it is suitable for your intended application or situation. You assume all risks and liability associated with such use or implementation.

Product Testing

We perform vigorous in-house safety and durability testing to ensure that the performance of our products meets the demands of the workplace. We also expect the same from manufacturers who supply components for our products. We do this to ensure that Valley Craft is a name that our customers trust and associate with quality.

Publication Revision Notice

Following is a history of changes to this publication, including the current revision.

Last Updated: 07/2011

Copyright Notice

© Valley Craft, Inc. All rights reserved. No part of this publication may be reproduced, photocopied, stored on a retrieval system, or transmitted without the express written consent of Valley Craft.

Trademarks

The Valley Craft logo is a Valley Craft Trademark. All other company or product names are trademarks or registered trademarks of their respective owners. Use of a term in this document should not be regarded as affecting the validity of any trademark or service mark.

■ Table of Contents

Safety	4-6
• Safety Overview	4
• Safety Message Conventions.....	5
• Safety Data Sheet	6
Product Description	7
• Specifications	7
• Features	7
Unpacking and Assembly	8
• Receiving and Inspection	8
Operation	8
• Operating Procedures	8
Maintenance and Adjustments	9
• Maintenance and Adjustment Procedures.....	9
Troubleshooting	10
• Trouble Shooting Procedures.....	10
Replacement	11
• Replacement Procedures.....	11
Parts List	12-13
• Replacement Parts.....	12-13

Safety

Read and understand all safety information and become familiar with all safety symbols contained in this section before moving, operating or performing maintenance on this equipment.

■ Safety Overview

The following general safety precautions must be observed during all phases of operation, service, and repair of this equipment. Failure to comply with these precautions or with specific safety messages elsewhere in this manual may impair the protection provided by the equipment. Such noncompliance would also violate safety standards of design, manufacture, and intended use of the instrument.

- Observe all safety signs posted in your facility.
- Observe warnings, cautions, handling information, storage requirements and other information on all container labels.
- Wear safety glasses with side shields.
- Wear the proper protective clothing, gloves and other protective equipment before handling any chemicals.
- Group the containers for the move by Hazard Class. Do not move acids with toxics, or oxidizers.
- Use maximum care and good judgment in preventing accidents and injuries and seeking first aid.
- Report unsafe conditions, equipment, practices, and on-job injuries.
- Understand your supervisor's instructions. Ask questions if you do not know how to do the job safely.
- Do not engage in tasks which you believe might be unsafe without consulting your supervisor.
- Clean up the work area and equipment upon job completion.
- Before you start work on any electrical system or circuit, check all power sources to ensure that the system or circuit is de-energized.
- Know the hazardous or potentially hazardous substances you work with or are present in your work area. Review Safety Data Sheets (SDS) on these substances, or contact your supervisor.

■ **Safety Message Conventions**

Three types of safety notices may be contained in this manual: **Danger**, **Warning** and **Caution** notices. These notices precede the procedural step or portion of text that presents the safety hazard.



DANGER

- **DANGER** indicates an imminently hazardous situation which, if not avoided, will result in death or serious injury. This signal word is to be limited to the most extreme situations.
-



WARNING

- **WARNING** indicates a potentially hazardous situation which, if not avoided, could result in death or serious injury.
-



CAUTION

- **CAUTION** indicates a potentially hazardous situation which, if not avoided, may result in minor or moderate injury. It may also be used to alert against unsafe practices
-

■ Safety Data Sheets (SDS)

A Safety Data Sheet (SDS) provides information on the safe use, handling and potential hazards of a product. This information assists with the proper response in the event of an emergency.

Valley Craft maintains safety data sheets (SDSs) on all our products. You are urged to obtain copies of the relevant SDSs before using our products to protect yourself and others against any known health or safety hazards described in these SDSs. Valley Craft strives to make safety a top priority. Do not hesitate to contact us to discuss any safety aspects of our products.

The relevant SDS codes for Valley Craft products are listed below.

- www.conocophillips.com
Super ATF Transmission Oil, SDS Code 778846
Super-Sta Grease, SDS Code 775440
- www.batteriesplus.com
Sealed Lead Acid Battery
SLA for English version
SLA Sp for the Spanish version
- [Paint](#)
Contact Valley Craft Customer Service at 1-800-328-1480 or on the Web at customerservice@valleycraft.com

■ Additional Safety Information

As with any mechanical device, care must be taken during the installation, operation, and maintenance of the device in order to realize the maximum benefit from its ownership.

Note: All personnel involved in the use and maintenance of this device should be thoroughly familiar with the information contained in this manual. Furthermore, it is recommended that all personnel be given adequate instruction and a sufficient period of training in its actual use to insure safety of personnel and proper care of the equipment. It is suggested that the units be initially operated empty until becoming familiar with operation of this unit.

Product Description

The **F89409A5 DRUM TILTER** is ideal for occasional one-sided drum pouring. Rotates 120°. Hand crank-operated tilter includes ratchets with poly straps.

■ Specifications

The **F89409A5 DRUM TILTER** specifications are shown in Table 1.

Table 1. Specifications

Dimensions	24 in. x 15 in. x 10 in.
Weight	70 lbs
Load Capacity	800 lbs

■ Features

The **F89409A5 DRUM TILTER** offers state-of-the-art design with many advanced features.

- 120° degree one sided rotation
- Ratchets with poly straps

■ **Receiving and Inspecting**

When unpacking the **F89409A5 DRUM TILTER**, inspect the equipment for damage or mishandling. If damage is noted, file a damage claim with the carrier within 24 hours and call Valley Craft at 1-800-328-1480. Do not attempt to use the equipment.

Compare the contents of the shipment with the bill of lading. Report any missing items to the carrier and to Valley Craft immediately.

■ **Operating Procedures**

Only authorized personnel are permitted to use the **F89409A5 DRUM TILTER**.

1. Attach Drum Tilter to Versa Lift back plate and center to prevent side-loading.
2. Move the Versa Lift forward, straddling the drum, and center the Drum Tilter arms to the drum. Push the Versa Lift forward until drum touches rear arms.
3. Pull both straps around the front of the drum and hook the metal ring onto the t-bar on the end of the Drum Rotator arms.
4. By depressing the “finger release” on the ratchet and returning it to its original position, you may now ratchet the straps tight around the drum.
5. With BOTH straps tight, raise the drum to the desired dumping height.
6. By turning the Drum Tilter handle, you may tilt the drum to the desired angle. (Max rotation is 120°)
7. To return drum to vertical, crank the handle the opposite direction

Maintenance and Adjustments

■ Maintenance and Adjustment Procedures

To keep the **F89409A5 DRUM TILTER** operating properly, timely maintenance and adjustments are required. These procedures should be performed only by qualified personnel who are familiar with the equipment.

Maintenance and adjustment procedures are shown in Table 1.

Table 1. Maintenance and Adjustment Procedures

Component	Frequency	Operation	Procedure
Tilter	Monthly	Grease	Locate zerks on front rotator
Worm Gear	Monthly	Grease	Locate zerks on worm gear
Straps	Daily	Inspection	Inspect straps for wear

Troubleshooting

■ Troubleshooting Procedures

The **F89409A5 DRUM TILTER** is a quality product that is designed and manufactured to provide prolonged service under normal operating conditions. If troubleshooting is required, it should be performed only by qualified personnel who are familiar with the equipment.

Replacement

■ Replacement Procedures

Occasionally, it will be necessary to replace a part that has been damaged or worn. Many parts on the **F89409A5 DRUM TILTER** are replaceable. If replacement of a part is required, it should be performed only by qualified personnel who are familiar with the equipment.

See Sheet 12 for available replacement parts. Identify the part number you need. Contact Valley Craft Customer Service at 1-800-328-1480 or on the Web at customerservice@valleycraft.com.

Information required when contacting Valley Craft:

- A. Company name and address
- B. Contact persons name
- C. Telephone number
- D. E-Mail address
- E. Model Number
- F. Date of manufacture
- G. Part number(s) of part(s) to be ordered

The model number and date of manufacture is stamped on a metal tag located front rotator.

DRM TILT UNIT

F89409A5
DRM TILT UNIT

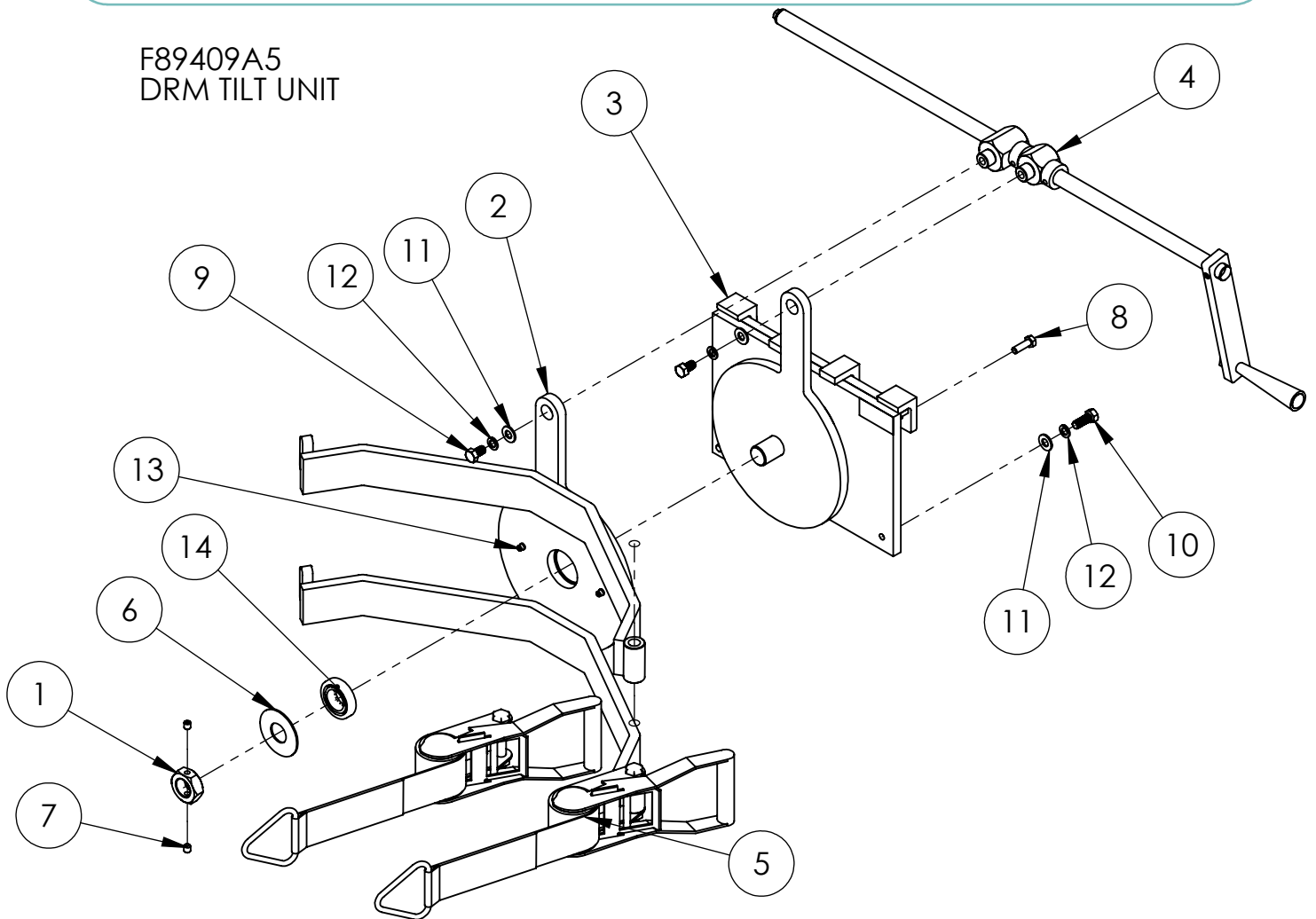

ITEM NO.	PART NUMBER	DESCRIPTION	Default/ QTY.
1	F52527A0	NUT-LOCK 1-14/DT	1
2	F60629A0	FRT SECT WLDMT/DT	1
3	F60630A7	BACK SECT WLDMT/DT	1
4	F62839A2	WORM GEAR-HDL ASSY	1
5	F62980A9	RATCHET ASSY-2.0X53.00 7000	2
6	Z10013A3	WASHER-1 ID X 2-7/16 X 5/64	1
7	Z10090A9	S-SHS 5/16-18X3/8	2
8	Z10123A0	S-HHC 5/16-18X1	2
9	Z10131A0	S-HHC 3/8-16X5/8	2
10	Z10132A9	S-HHC 3/8-16X1	2
11	Z10202A4	WASHER-3/8 FLAT SAE	4
12	Z10214A0	WASHER-3/8 LOCK MD	4
13	Z10627A7	ZERK-GREASE .188 DRIVE	2
14	Z30420A8	BRG-TAPER ROLL 1"BOR	1
15	Z40469A9	DECAL-LOAD CAP 800	1

DRM TILT UNIT

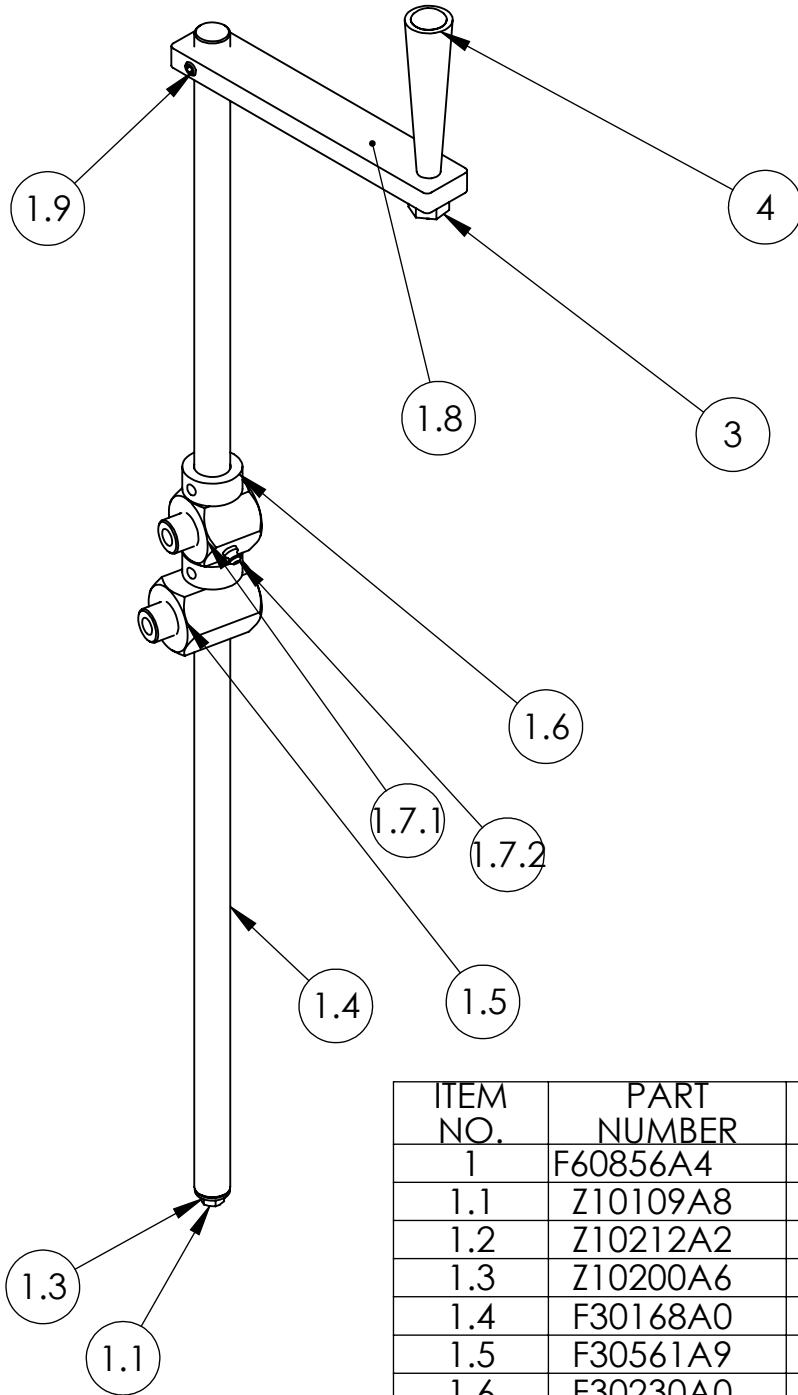

ITEM NO.	PART NUMBER	DESCRIPTION	QTY.
1	F60856A4	WORM GEAR ASSY/DT	1
1.1	Z10109A8	S-HHC 1/4-20X1/2	1
1.2	Z10212A2	WASHER-1/4 LOCK MD	1
1.3	Z10200A6	WASHER-1/4 FLAT USS	1
1.4	F30168A0	ROD-THREADED/DT	1
1.5	F30561A9	NUT-THRD/DT LNG	1
1.6	F30230A0	COLLAR LCK 49/64 ID	2
1.7	F61009A8	NUT ASSY-STNRY/DT	1
1.7.1	F30170A6	NUT-STNRY/DT	1
1.7.2	Z10627A7	ZERK-GREASE .188 DRIVE	1
1.8	F51739	HDL/DT	1
1.9	Z10090A9	S-SHS 5/16-18X3/8	1
2	Z10002A6	S-CRG 1/2-13x5	1
3	Z10020A4	NUT-HEX FULL 1/2-13	1
4	Z50030A8	HDL-BLK/DTILT	1

Warranty and Limitation of Liability

Valley Craft products are warranted for a period of one (1) year from date of shipment from Valley Craft's plant to be free from defects in material and workmanship under correct use, normal operation and proper application. However, parts of other than Valley Craft manufacture are subject ONLY to the original manufacturer's warranty. Valley Craft's obligation under warranty shall be limited to repair or exchange, at Valley Craft's option, FOB origin factory, of any Valley Craft product or part which proves to be defective as provided herein. Valley Craft reserves the right to either inspect the product at Buyer's location, or require it to be returned to the factory for inspection. The warranty contained herein does not extend to goods damaged, or subject to accident, abuse or misuse after shipment from Valley Craft's factory, nor to goods altered or repaired by anyone other than an authorized Valley Craft representative.

Buyer or user shall not alter, modify or use a Valley Craft product for anything other than its intended function. Valley Craft shall not in any way be responsible for the consequences of any such alteration, modification or misuse.

VALLEY CRAFT MAKES NO EXPRESS WARRANTIES OTHER THAN THOSE WHICH ARE SPECIFICALLY DESCRIBED HEREIN. Any description of the goods sold hereunder, including any references to Buyer's specifications and any descriptions in catalogs, circulars and other written material published by Valley Craft, is for the sole purpose of identifying such goods and shall not create an express warranty that the goods shall conform to such descriptions.

THIS WARRANTY IS EXPRESSLY IN LIEU OF ALL OTHER WARRANTIES, EXPRESS OR IMPLIED. THERE ARE NO IMPLIED WARRANTIES OF MERCHANTABILITY OR FITNESS FOR A PARTICULAR PURPOSE. THIS WARRANTY STATES VALLEY CRAFT'S ENTIRE AND EXCLUSIVE LIABILITY AND BUYER'S EXCLUSIVE REMEDY FOR ANY CLAIM OR DAMAGES IN CONNECTION WITH VALLEY CRAFT PRODUCTS, THEIR DESIGN, SUITABILITY FOR USE, INSTALLATION OR OPERATION OR FOR ANY CLAIMED DEFECTS. VALLEY CRAFT WILL IN NO EVENT BE LIABLE FOR INCIDENTAL OR CONSEQUENTIAL DAMAGES WHATSOEVER, NOR FOR ANY SUM IN EXCESS OF THE PRICE RECEIVED FOR THE GOODS FOR WHICH LIABILITY IS CLAIMED.

Technical Assistance/Warranty Procedure

What's Covered:

- Parts and Labor to correct manufacturer's defect within one year of purchase.
- Freight Cost

What's Not:

- Normal wear items (seal kits, bearings, tires, etc.)

What Voids the Warranty:

- Dirt/Grime that directly causes malfunction of product
 - Abuse (i.e. Overloading, damaged, not properly maintained, etc.)
 - Product altered by customer
- *See "Items not Under Warranty" below for items that have the warranty voided.

Items Under Warranty (less than one year old):

- Warranty replacement parts are provided only when the problem can be identified with near certainty. If not, the customer will return item to Valley Craft, freight collect, for troubleshooting and/or repair. When repaired, product will be returned to customer,



Valley Craft is a family-owned company based in Minnesota. Founded in 1953 with the introduction of the first hand truck with a brake, Valley Craft has grown to be a world class manufacturer known for producing material handling, storage, and safety solutions that truly stand the test of time.

Our commitment to building only the most rugged and reliable products - together with a relentless and uncompromising dedication to customer satisfaction is what sets Valley Craft apart.

Through thoughtful and intelligent design, we have helped transform the way people work. Over the years, we have helped solve some of the most complex material handling challenges. We help our customers to become better organized and to work smarter, safer, and more efficiently. As our breadth of products continues to evolve with every new innovation, our core values stay the same:

Professional Grade Quality.... Built to Last.... Made in the U.S.A.

Valley Craft, Inc.

2001 South Highway 61

Lake City, Minnesota 55401 U.S.A.

www.valleycraft.com 

customerservice@valleycraft.com 

651-345-3386 