

ROTOGRIP BATTERY POWERED



INSTRUCTION MANUAL

VALLEY CRAFT, INC. 2001 SOUTH HWY. 61, LAKE CITY, MN 55041 PH: 1-800-328-1480

Last Updated 11/10

Z41593A7

TABLE OF CONTENTS

A.	OPERATING INSTRUCTIONS	PG. 3
B.	SAFETY, MAINTENANCE, & MSDS INFO	PG. 4
C.	BATTERY CHARGING INSTRUCTIONS	PG. 5
D.	PARTS DIAGRAM	PG. 6-7
E.	CONTROL BOX PARTS	PG. 8
F.	FRONT SECTION PARTS	PG. 9-10
G.	PANEL ASSEMBLY	PG. 11
H.	HYDRAULIC/ELECTRICAL SCHEMATIC	PG. 12
I.	TROUBLESHOOTING CHART	PG. 13
J.	WARRANTY STATEMENT	PG. 14

A. Operating Instructions

NOTE: IT IS RECOMMENDED THAT ALL OPERATORS FAMILIARIZE THEMSELVES WITH THE MACHINE AND DEVELOP SAFE WORKING HABITS.

1. **IMPORTANT!** Remove solid plug on hydraulic reservoir and install breather cap (included in the Power Pak) for proper air venting.
2. Install battery with the negative pole on the left hand side. Do not allow ground wire to come in contact with any other wires or a short will occur.
3. Move the Rotogrip forward, straddling the drum, and center the rotating jaws to the drum using the “UP/DOWN” switch on the control panel.
4. After jaws are centered on drum, push the unit forward the rest of the way so the drum touches the rear of the jaws.
5. By simultaneously depressing the “ON” button and the “CLAMP” switch on the control panel securely squeeze the drum.
NOTE: The “ON” button must be depress before the clamping mode is operational.
6. With the drum clamped, raise the drum by using the “UP” switch.
7. To dump, raise the drum to the desired height and then depress the “ROTATE” switch, on top of the enclosure, in the direction you want the drum to dump.

B. Safety Instructions

1. When transporting a load, it is recommended that the drum is lowered as close to the floor as possible to reduce the chance of accidents during transport.
2. Do not leave load suspended for an extended period of time or premature wear to the lifting cylinder will occur.
3. Maximum lifting capacity is 800 pounds.

C. Maintenance Information

1. Use 12 Volt 80AH sealed lead acid AGM battery. Approximate dimensions of the battery is 10 ¼ long x 6 ¾ wide x 8 3/8 high (to top of terminals). Battery warranty is free replacement within one year of purchase.
2. Check hydraulic fluid every 40 hours or before using the machine after long set-aside periods. Three quarts of hydraulic fluid is sufficient to operate the system properly. Do no overfill. Use Dexron automatic transmission fluid only!
3. The lifting chain should be oiled periodically as needed. This is best accomplished by lowering the backplate completely and spraying lubricant onto the chain.
4. The front section assembly has two grease zerks on the backplate and should be greased every 100 hours of use.
5. Check rubber lining on jaws occasionally to insure they are in good condition (not worn, ripped, etc.) or drums may slip from the grip.

MATERIAL SAFETY DATA SHEETS (MSDS)

A Material Safety Data Sheet (MSDS) provides information on the safe use, handling and potential hazards of a product. This information assists with the proper response in the event of an emergency.

Valley Craft maintains material safety data sheets (MSDS) on all our products. You are urged to obtain copies of the relevant MSDSs before using our products to protect yourself and others against any known health or safety hazards described in these MSDSs. Valley Craft strives to make safety a top priority. Do not hesitate to contact us to discuss any safety aspects of our products.

The relevant MSDS codes for Valley Craft products are listed below.

www.conocophillips.com

Super ATF Transmission Oil, MSDS Code 778846

Super-Sta Grease, MSDS Code 775440

www.batteriesplus.com

Sealed Lead Acid Battery

SLA for English version

SLA Sp for the Spanish version

[Paint](#)

Contact Valley Craft Customer Services at 1-800-328-1480 or on the web at customer@valleycraft.com

E. Battery Charging Instructions

1. Plug a grounded extension cord into built-in receptacle in Control Box and plug into outlet.
2. The Roto Grip is charged automatically, and can be left unattended while charging.
3. When re-charging is accomplished, unplug extension cord from Control Box.

NOTES:

- A. Generally, batteries will require equal charging to work time (ex. One hour of machine use = one hour of re-charging time).
- B. It is not recommended that alternate charging devices be used.
- C. **CAUTION!** To avoid shock or burn, **NEVER** touch the unit while recharging.

PARTS BREAKDOWN
F88585C3 ROTOGRIP-78
F58586C2 ROTOGRIP-90

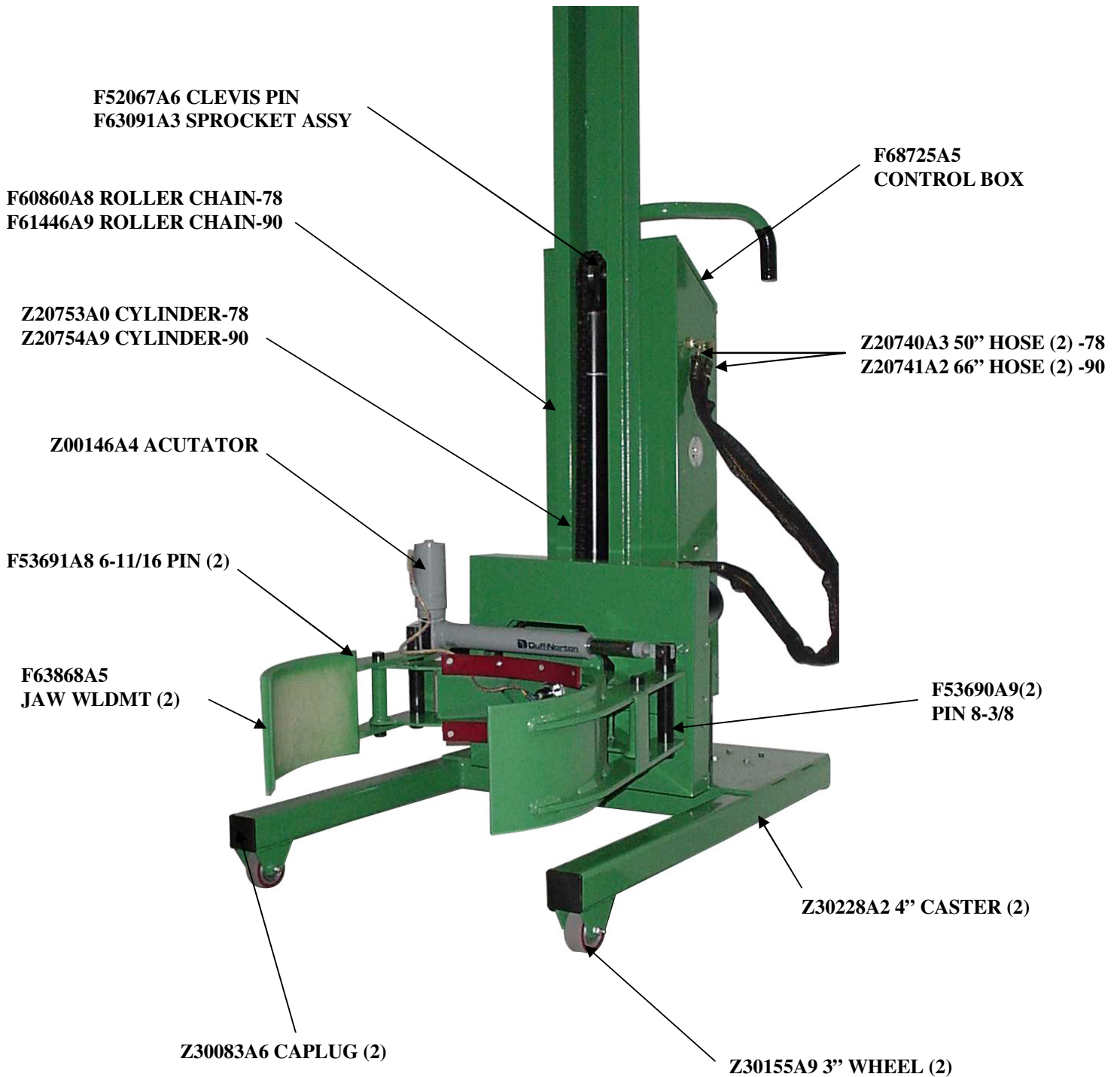

BACKPLATE ASSEMBLY
F64367A4

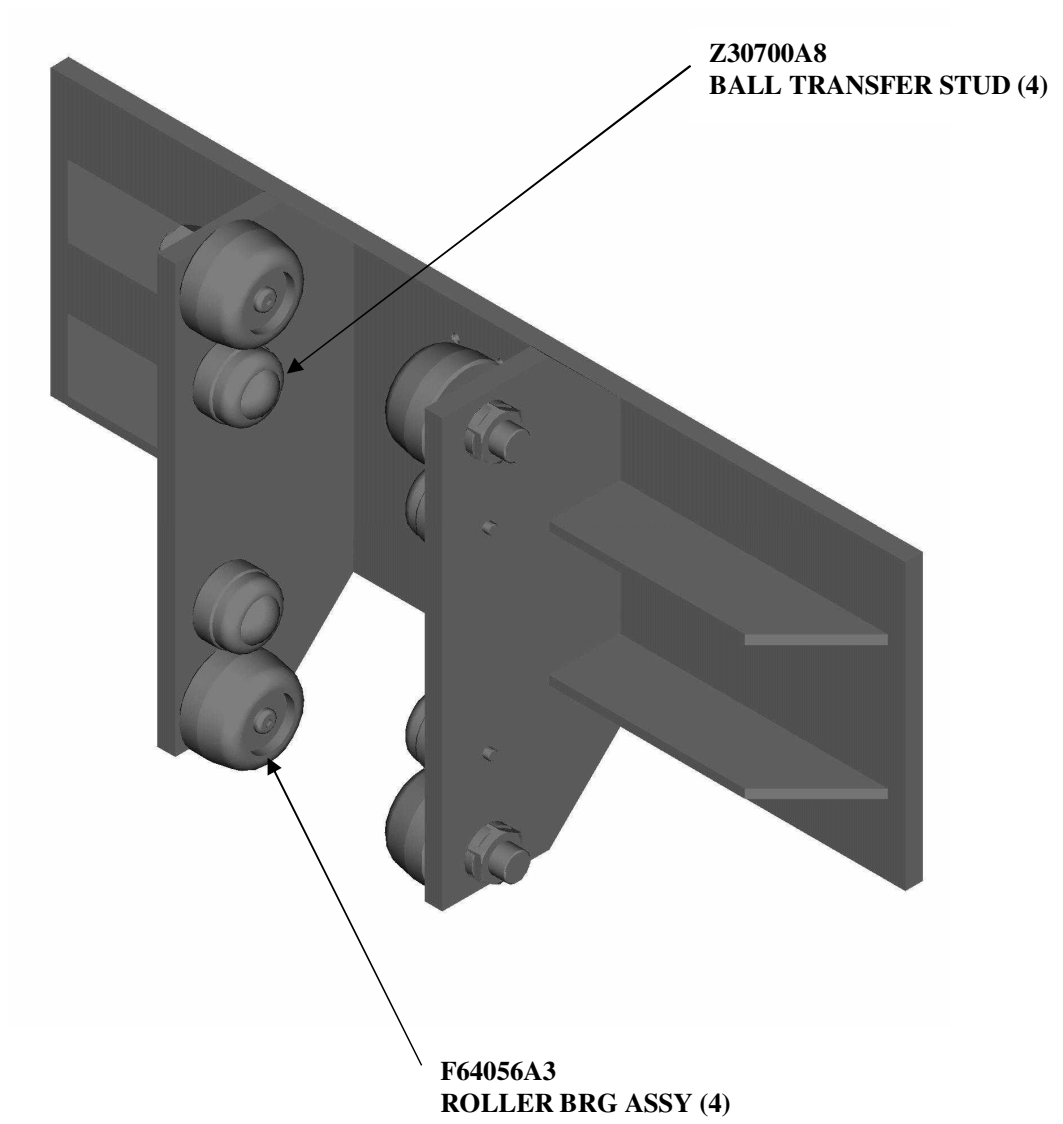

CONTROL BOX ASSY
F68725A5

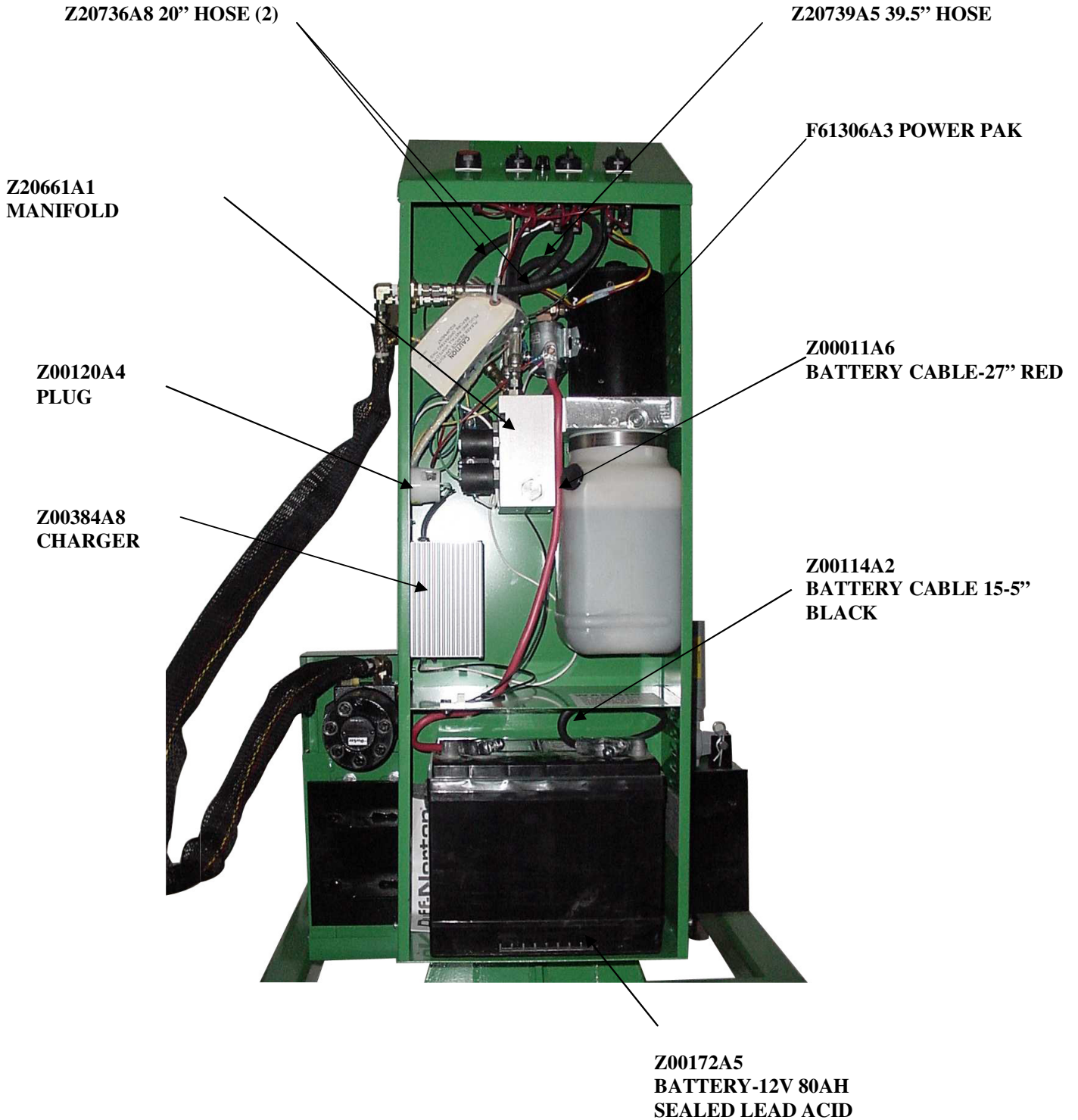

Z20736A8 20" HOSE (2)

Z20739A5 39.5" HOSE

Z20661A1
MANIFOLD

F61306A3 POWER PAK

Z00120A4
PLUG

Z00011A6
BATTERY CABLE-27" RED

Z00384A8
CHARGER

Z00114A2
BATTERY CABLE 15.5"
BLACK

Z00172A5
BATTERY-12V 80AH
SEALED LEAD ACID

PARTS BREAKDOWN
FRONT SECTION ASSEMBLY
F63161B8

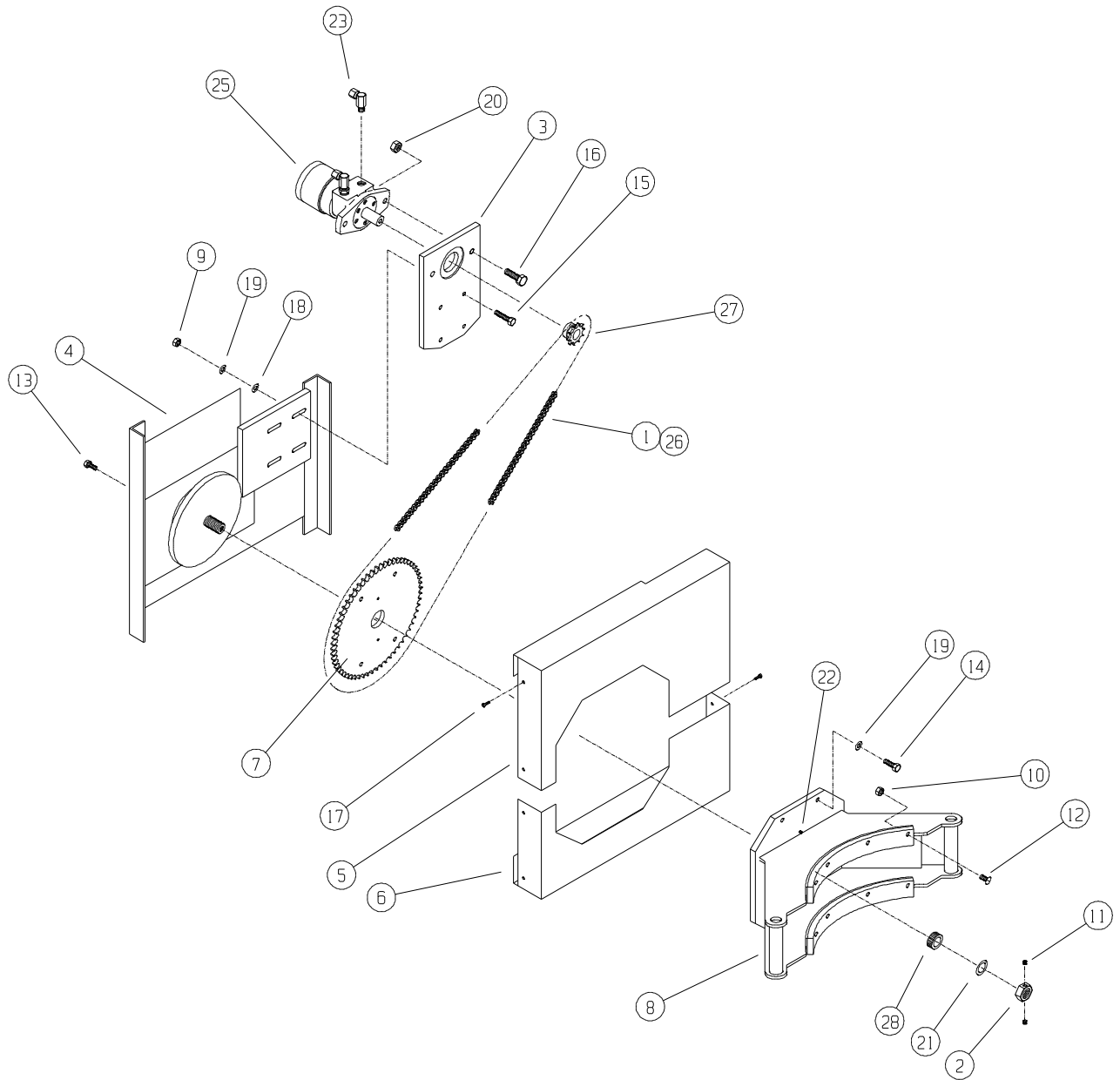

PARTS LIST

ITEM	PART NUMBER	DESCRIPTION	QTY.
1	F30214A4	CHAIN-ROLLER	1
2	F52527A0	NUT-LOCK 1-14	1
3	F52651A8	MOTOR MOUNT	1
4	F62630A3	BACK SECTION	1
5	F52648A4	TOP-CHAIN GUARD	1
6	F52649A3	BOTTOM-CHAIN GUARD	1
7	F52650A9	SPROCKET-LARGE	1
8	F63790A3	ARM WELDMENT	1
9	Z10026A8	HEX JAM NUT 3/8-16	4
10	Z10035A7	NUT-HEX KEPS 1/4-20	8
11	Z10090A9	S-SHS 5/16-18X3/8	2
12	Z10099A0	FLAT HD SCREW 1/4-20X3/4	8
13	Z10122A1	S-HHC 5/16-18X3/4	2
14	Z10132A9	S-HHC 3/8-16X1	4
15	Z10134A7	HEX SCREW 3/8-16X1-1/2	4
16	Z10148A1	HEX SCREW 1/2-13X1-1/2	2
17	Z10166A8	SCREW #10-24X1/2	8
18	Z10202A4	FLAT WASHER 3/8 SAE	4
19	Z10214A0	LOCKWASHER 3/8	8
20	Z10393A3	NUT-LOCK 1/2-13	2
21	Z10430A5	BUSH-MACH 1X14GAX2	1
22	Z10627A7	GREASE ZERK	2
23	Z20701A3	FTG 90 6801-6-10 NWO	2
25	Z20656A6	HYDRAULIC MOTOR	1
26	Z30059A6	CONNECTING LINK	1
27	Z30400A2	SPROCKET-SMALL	1
28	Z30420A8	1" TAPERED ROLLER BRG	1
29	Z41024A4	RED URETHANE	2

TOP PANEL CONTROL BOX F68729A1

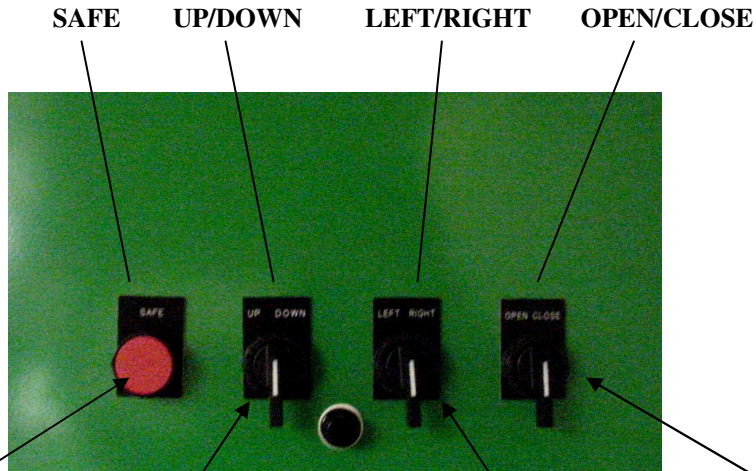

Z00522A8
RED PUSHBUTTON

Z00524A6
CONTACT BLOCK N/O

Z300523A7
3-POSITION SWITCH

Z00524A6
CONTACT BLOCK N/O

Z00542A8
CONTACT BLOCK 2 N/O

Z00523A7
3-POSITION SWITCH

Z00542A8 (2)
CONTACT BLOCK 2 N/O

Z00523A7
3-POSITION SWITCH

Z00542A8 (2)
CONTACT BLOCK 2 N/O

CONTACT BLOCK LOCATIONS

Z00524A6
CONTACT BLOCK N/O

F68726A4
WIRE HARNESS

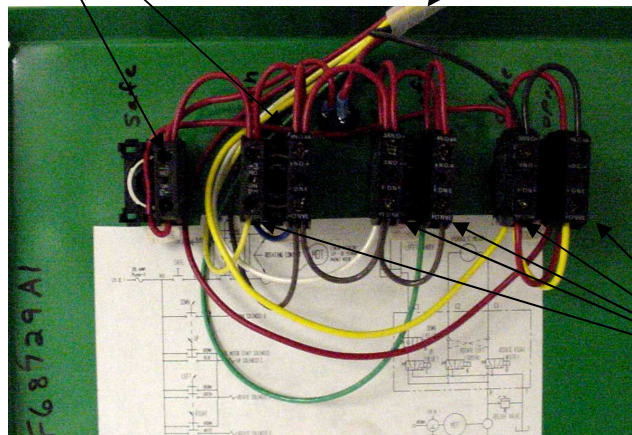

Z00542A8
CONTACT BLOCK 2 N/O

HYDRAULIC/ELECTRICAL SCHEMATIC

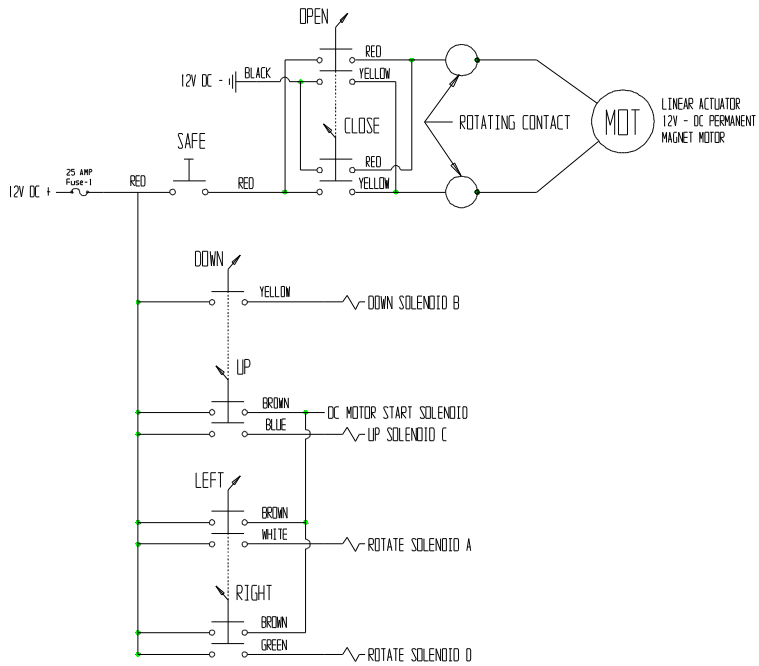

ELECTRICAL WIRING

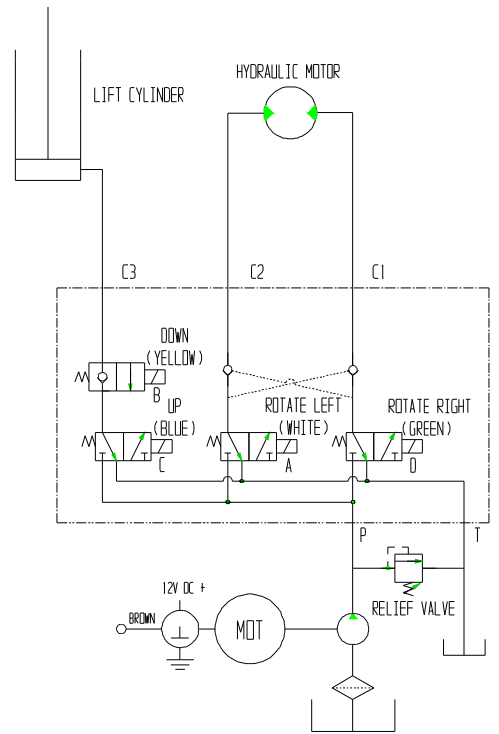

HYDRAULIC SCHEMATIC

TROUBLESHOOTING GUIDE

PROBLEM	POSSIBLE CAUSE	SOLUTION
Batteries won't charge	Faulty Battery(s) Not following recharging directions Improper grounding/wiring	Load test Batteries to ensure it is good. If battery is bad see page 7 for replacement. Refer to Battery Charging Instructions (Page 4) Tighten Charger mounting bolts and check wiring
Unit not functioning	Low/Dead Batteries Improper grounding Damaged or loose wiring Bad Switches	Recharge Batteries Check Motor & Battery wire connections. Tighten if necessary Check wiring to switches in Control Box. Re-attach loose connections. Call factory for replacement

Warranty & Limitation of Liability

Valley Craft products are warranted for a period of one (1) year from date of shipment from Valley Craft's plant to be free from defects in material and workmanship under correct use, normal operating and proper application. However, parts of other than Valley Craft manufacture are subject ONLY to the original manufacturer's warranty. Valley Craft's obligation under warranty shall be limited to repair or exchange, at Valley Craft's option, FOB origin factory, of any Valley Craft product or part which proves to be defective as provided herein. Valley Craft reserves the right to either inspect the product at Buyer's location, or require it to be returned to the factory for inspection. The warranty contained herein does not extend to goods damaged, or subject to accident, abuse or misuse after shipment from Valley Craft's factory, nor to goods altered or repaired by anyone other than an authorized Valley Craft representative.

Buyer or user shall not alter, modify or use a Valley Craft product for anything other than its intended function. Valley Craft shall not in any way be responsible for the consequences of any such alteration, modification or misuse.

VALLEY CRAFT MAKES NO EXPRESS WARRANTIES OTHER THAN THOSE WHICH ARE SPECIFICALLY DESCRIBED HEREIN. Any description of the goods sold hereunder, including any references to Buyer's specifications and any descriptions in catalogs, circulars and other written material published by Valley Craft, is for the sole purpose of identifying such goods and shall not create an express warranty that the goods shall conform to such descriptions.

THIS WARRANTY IS EXPRESSLY IN LIEU OF ALL OTHER WARRANTIES, EXPRESS OR IMPLIED. THERE ARE NO IMPLIED WARRANTIES OF MERCHANTABILITY OR FITNESS FOR A PARTICULAR PURPOSE. THIS WARRANTY STATES VALLEY CRAFT'S ENTIRE AND EXCLUSIVE LIABILITY, AND BUYER'S EXCLUSIVE REMEDY FOR ANY CLAIM FOR DAMAGES IN CONNECTION WITH VALLEY CRAFT PRODUCTS, THEIR DESIGN, SUITABILITY FOR USE, INSTALLATION OR OPERATION OR FOR ANY CLAIMED DEFECTS. VALLEY CRAFT WILL IN NO EVENT BE LIABLE FOR INCIDENTAL OR CONSEQUENTIAL DAMAGES WHATSOEVER, NOR FOR ANY SUM IN EXCESS OF THE PRICE RECEIVED FOR THE GOODS FOR WHICH LIABILITY IS CLAIMED.

Technical Assistance/Warranty Procedure

What's Covered:

- Parts and Labor to correct manufacturer's defect within one year of purchase.
- Freight Cost

What's Not:

- Normal wear items (seal kits, bearings, tires, etc.)

What Voids the Warranty:

- Dirt/Grime that directly causes malfunction of product
 - Abuse (i.e. Overloading, damaged, not properly maintained, etc.)
 - Product altered by customer
- *See "Items not Under Warranty" below for items that have the warranty voided.

Items Under Warranty (less than one year old):

- Warranty replacement parts are provided only when the problem can be identified with near certainty. If not, the customer will return item to Valley Craft, freight collect, for troubleshooting and/or repair. When repaired, product will be returned to customer, freight prepaid. Otherwise, customer may call local authorized service technician for assistance. Under this arrangement, replacement parts will be sent at no charge but labor costs will NOT be covered.

Items NOT Under Warranty (greater than one year old or *having warranty voided):

- Customer will return item to Valley Craft, freight prepaid, for troubleshooting and/or repair. Valley Craft will call customer with \$\$ estimate of parts and labor for approval before repairing. Product will be returned to customer, freight collect.

Or

- Customer may call local authorized service technician for repairs at their own expense.

Z4008 1A7