

SOLUTIONS TO SIMPLIFY YOUR WORKLOAD
Material Handling, Storage & Specialized Equipment

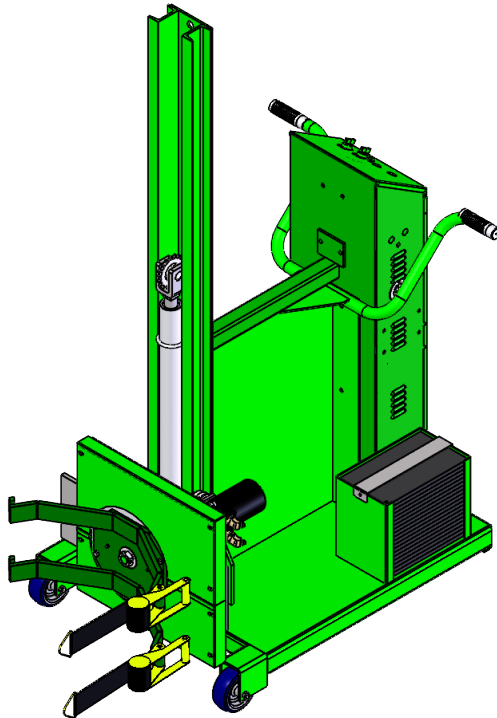

BATTERY POWERED 90 & 78



Notice to Purchaser

All statements, technical information, and recommendations related to Valley Craft's products are based on information believed to be reliable, but the accuracy or completeness is not guaranteed. Before using this product, you must determine if it is suitable for your intended application or situation. You assume all risks and liability associated with such use or implementation.

Product Testing

We perform vigorous in-house safety and durability testing to ensure that the performance of our products meets the demands of the workplace. We also expect the same from manufacturers who supply components for our products. We do this to ensure that Valley Craft is a name that our customers trust and associate with quality.

Publication Revision Notice

Following is a history of changes to this publication, including the current revision.

Previously Updated: 11/2019

Last Updated: 01/2021

Copyright Notice

© Valley Craft, Inc. All rights reserved. No part of this publication may be reproduced, photocopied, stored on a retrieval system, or transmitted without the express written consent of Valley Craft.

Trademarks

The Valley Craft logo is a Valley Craft Trademark. All other company or product names are trademarks or registered trademarks of their respective owners. Use of a term in this document should not be regarded as affecting the validity of any trademark or service mark.

■ Table of Contents

Safety	4-6
• Safety Overview	4
• Safety Message Conventions.....	5
• Material Safety Data	6
Product Description	7
• Specifications	7
• Features	7
Unpacking and Assembly	8
• Receiving and Inspection	8
Operation	8
• Operating Procedures	8
Maintenance and Adjustments	9-10
• Maintenance and Adjustment Procedures.....	9
• Charging Battery	10
Troubleshooting	11
• Troubleshooting Procedures	11
Replacement	12
• Replacement Procedures.....	12
Parts List	13-20
• Rotolift Isometric & BOM	13-14
• Backplate Assy & BOM	15
• Control Box & BOM	16-17
• Front Section & BOM	18-19
• Hydraulic Power Unit.....	20
Equipment Drawings	21-22
• Hydraulic Schematic.....	21
• Electrical Diagram	22
Warranty Information	23
• Warranty and Limitation of Liability.....	23
• Technical Assistance/Warranty Procedure.....	23

Safety

Read and understand all safety information and become familiar with all safety symbols contained in this section before moving, operating or performing maintenance on this equipment.

■ Safety Overview

The following general safety precautions must be observed during all phases of operation, service, and repair of this equipment. Failure to comply with these precautions or with specific safety messages elsewhere in this manual may impair the protection provided by the equipment. Such noncompliance would also violate safety standards of design, manufacture, and intended use of the instrument.

- Observe all safety signs posted in your facility.
- Observe warnings, cautions, handling information, storage requirements and other information on all container labels.
- Wear safety glasses with side shields.
- Wear the proper protective clothing, gloves and other protective equipment before handling any chemicals.
- Group the containers for the move by Hazard Class. Do not move acids with toxics, or oxidizers.
- Use maximum care and good judgment in preventing accidents and injuries and seeking first aid.
- Report unsafe conditions, equipment, practices, and on-job injuries.
- Understand your supervisor's instructions. Ask questions if you do not know how to do the job safely.
- Do not engage in tasks which you believe might be unsafe without consulting your supervisor.
- Clean up the work area and equipment upon job completion.
- Before you start work on any electrical system or circuit, check all power sources to ensure that the system or circuit is de-energized.
- Know the hazardous or potentially hazardous substances you work with or are present in your work area. Review Material Safety Data Sheets (MSDS) on these substances, or contact your supervisor.

■ Safety Message Conventions

There are three types of safety notices contained in this manual: **Danger**, **Warning** and **Caution** notices. These notices precede the procedural step or portion of text that presents the safety hazard.



DANGER

- **DANGER** indicates an imminently hazardous situation which, if not avoided, will result in death or serious injury. This signal word is to be limited to the most extreme situations.
-



WARNING

- **WARNING** indicates a potentially hazardous situation which, if not avoided, could result in death or serious injury.
-



CAUTION

- **CAUTION** indicates a potentially hazardous situation which, if not avoided, may result in minor or moderate injury. It may also be used to alert against unsafe practices
-

■ Material Safety Data Sheets (MSDS)

A Material Safety Data Sheet (MSDS) provides information on the safe use, handling and potential hazards of a product. This information assists with the proper response in the event of an emergency.

Valley Craft maintains material safety data sheets (MSDSs) on all our products. You are urged to obtain copies of the relevant MSDSs before using our products to protect yourself and others against any known health or safety hazards described in these MSDSs. Valley Craft strives to make safety a top priority. Do not hesitate to contact us to discuss any safety aspects of our products.

The relevant MSDS codes for Valley Craft products are listed below.

- www.conocophillips.com
Super ATF Transmission Oil, MSDS Code 778846
Super-Sta Grease, MSDS Code 775440
- www.batteriesplus.com
Sealed Lead Acid Battery
SLA for English version
SLA Sp for the Spanish version
- [Paint](#)
Contact Valley Craft Customer Service at 1-800-328-1480 or on the Web at customerservice@valleycraft.com

■ Additional Safety Information

As with any mechanical device, care must be taken during the installation, operation, and maintenance of the device in order to realize the maximum benefit from its ownership.

When raising and lowering the load, be aware of pinch points. Keep hands and feet away from these areas.

When transporting a load, it is recommended that the load is lowered as close to the floor as possible to reduce the chance of accidents during transport.

Do not leave load suspended for an extended period of time or premature wear to the lifting cylinder may occur.

Note: All personnel involved in the use and maintenance of this device should be thoroughly familiar with the information contained in this manual. Furthermore, it is recommended that all personnel be given adequate instruction and a sufficient period of training in its actual use to insure safety of personnel and proper care of the equipment. It is suggested that the units be initially operated empty until becoming familiar with how the unit handles.

Product Description

The **Rotolift** drum handler is a manually-propelled straddle-type unit that centers the load between the wheels for maximum balance and safety. Lifts and Rotates 360 degrees.

■ Specifications

The **Rotolift** specifications are shown in Table 1.

Table 1. Specifications

Dimensions	Height: Model Dependent (78" / 90") Width: 30. Depth: 45.75
Weight	1155 lbs
Load Capacity	800 lbs
Power	12VDC
Lift Travel	Model Dependent (58" / 71")
Rotation	360 degrees continuous

■ Features

The **Rotolift** offers state-of-the-art design with many advanced features.

- 12 volt deep cycle battery
- On-board charging system
- Electric over hydraulic power unit (PU/GD)
- Hydraulic Cylinder for lift function
- Hydraulic orbit motor for rotate function
- Heavy Duty ratchet straps to secure drum
- Portable / Straddle design
- Intermittent rotary switches for all functions

■ Receiving and Inspecting

When unpacking the **Versa-Lift**, inspect the equipment for damage or mishandling. If damage is noted, file a damage claim with the carrier within 24 hours and call Valley Craft at 1-800-328-1480. Do not attempt to use the equipment.

Compare the contents of the shipment with the bill of lading. Report any missing items to the carrier and to Valley Craft immediately.

■ Operating Procedures

Only authorized personnel are permitted to use the **ROTO-Lift**. Every load and every situation is different. Every lift must be evaluated and planned. Observe the following procedures when using this equipment.

PRIOR TO OPERATION

- Remove the solid plug on the hydraulic reservoir and install the breather cap attached to the motor for proper air venting.
- Remove the solid plug on the left side of the motor nearest the mast and install the lubricator, regulator, gauge and the filter in this order.

OPERATION PROCEDURE

- Attach air line to unit (100psi @ 50cfm recommended)
- Loosen rotator straps in the following way. A) Depress “finger release” on ratchet and fold handle open. B) Pull strap through ratchet just far enough to unhook metal ring from T-bar at the end of the rotating arm. C) Perform this on both ratchets.
- Move the Roto-Lift forward, straddling the drum, and center the rotating arms to the drum using the appropriate lever.
- After arms are centered on drum, push unit forward the rest of the way so the drum touches the rear of the rotating arms.
- Pull both straps around the front of the drum and hook the metal ring onto the T’bar on the end of the rotating arms.
- By depressing the “finger release” on the ratchet and returning it to the original position, you may now ratchet the straps tight around the drum.
- With BOTH straps tight, raise the drum using the appropriate lever.
- To dump, raise the drum to the desired height and activate appropriate lever

Maintenance and Adjustments

■ Maintenance and Adjustment Procedures

To keep the **ROTO-Lift** operating properly, timely maintenance and adjustments are required. These procedures should be performed only by qualified personnel who are familiar with the equipment.

As with any mechanical hydraulic actuator (piston rods, rotating pump shaft, etc.) the shaft will become coated with a minute amount of oil from the internal high pressure system. The rod protruding from the cylinder and foot pump may feel damp with oil after use. This is desirable because the oil coating serves to lubricate the shaft seal, reducing friction and assuring extended seal life.

Maintenance and adjustment procedures are shown in Table 2.

Table 2. Maintenance and Adjustment Procedures

Component	Frequency	Operation	Procedure
Hydraulic Fluid	Every 40 hours or after long set-aside periods	Visually inspect	Make sure cylinder is fully retracted. Fill Reservoir to within 1 in. to 2 in. of the fill hole. Use ATF D/M Transmission Fluid.
	Yearly	Flush hydraulic system	Drain all hydraulic fluid and replace with 64 ounces of Super ATF Transmission Fluid. Make sure cylinder is fully retracted
Hydraulic System	Monthly	Visually Inspect	Inspect for leaks and damaged hydraulic lines and correct as required
	At Start of Shift	Operate	Fully extend lift cylinder to purge oil from rod end of the cylinder
Electrical System	Monthly	Visually Inspect	Inspect for damaged or frayed wires and correct as required
Chain	As required	Lubricate	Oil Chain
Nylon Straps	At Start of Shift	Visually Inspect	Check nylon straps for wear and replace as necessary

■ Charging Batteries

1. To charge your battery, plug a grounded extension cord into the built-in receptacle in the Control Box and an outlet.
2. The battery will charge automatically after the charger is plugged in and can be left unattended.
 - Batteries will generally require equal charging to work time.
3. Keep the charger plugged in to maintain a full battery level when the unit is not being used.

NOTES:

- See charger **MANUAL** for **SAFETY PRECAUTIONS** and charger **TROUBLESHOOTING**.
- **DO NOT USE BATTERIES UNTIL THEY ARE TOTALLY DISCHARGED.**
 - i. Doing so may damage your battery.
 - ii. For maximum battery life, your unit is equipped with a charger that collects information from the battery and adjusts the current and voltage accordingly. If your battery voltage drops below a certain threshold the charger will not charge the battery.
- If the battery becomes discharged and won't charge by ordinary means, a suggested solution is to “trick” the charger into reading a higher voltage from the battery. To do this connect a second, well-charged battery (12.4 volts or greater) in parallel with the dead battery-positive to positive, negative to negative. Then plug in your charger and charge the combination until the dead battery has enough voltage to enable being charged by itself.

Troubleshooting

■ Troubleshooting Procedures

The **Roto-Lift** is a quality product that is designed and manufactured to provide prolonged service under normal operating conditions. If troubleshooting is required, it should be performed only by qualified personnel who are familiar with the equipment.

■ Replacement Procedures

Occasionally, it will be necessary to replace a part that has been Damaged or worn. Many parts on this Versa-Lift are replaceable. If Replacement of a part is required, it should be performed only by Qualified personnel who are familiar with the equipment.

See the following pages for available replacement parts. Identify the part number you need. Contact Valley Craft Customer Service at 1-800-328-1480 or on the Web at customer@valleycraft.com.

Information required when contacting Valley Craft:

- A. Company name and address
- B. Contact persons name
- C. Telephone number
- D. E-Mail address
- E. Model Number
- F. Date of manufacture
- G. Part number of Parts ordering

The model number and date of manufacture is stamped on a metal tag located on the frame above the push handle.

Replacement

■ Replacement Procedures

Occasionally, it will be necessary to replace a part that has been Damaged or worn. Many parts on this Rotolift are replaceable. If Replacement of a part is required, it should be performed only by Qualified personnel who are familiar with the equipment.

See the following pages for available replacement parts. Identify the part number you need. Contact Valley Craft Customer Service at 1-800-328-1480 or on the Web at customer@valleycraft.com.

Information required when contacting Valley Craft:

- A. Company name and address
- B. Contact persons name
- C. Telephone number
- D. E-Mail address
- E. Model Number
- F. Date of manufacture
- G. Part number of Parts ordering

The model number and date of manufacture is stamped on a metal tag located on the back side of the frame just above the push handle.

F88569C3 - ROTO C/W Lift-78

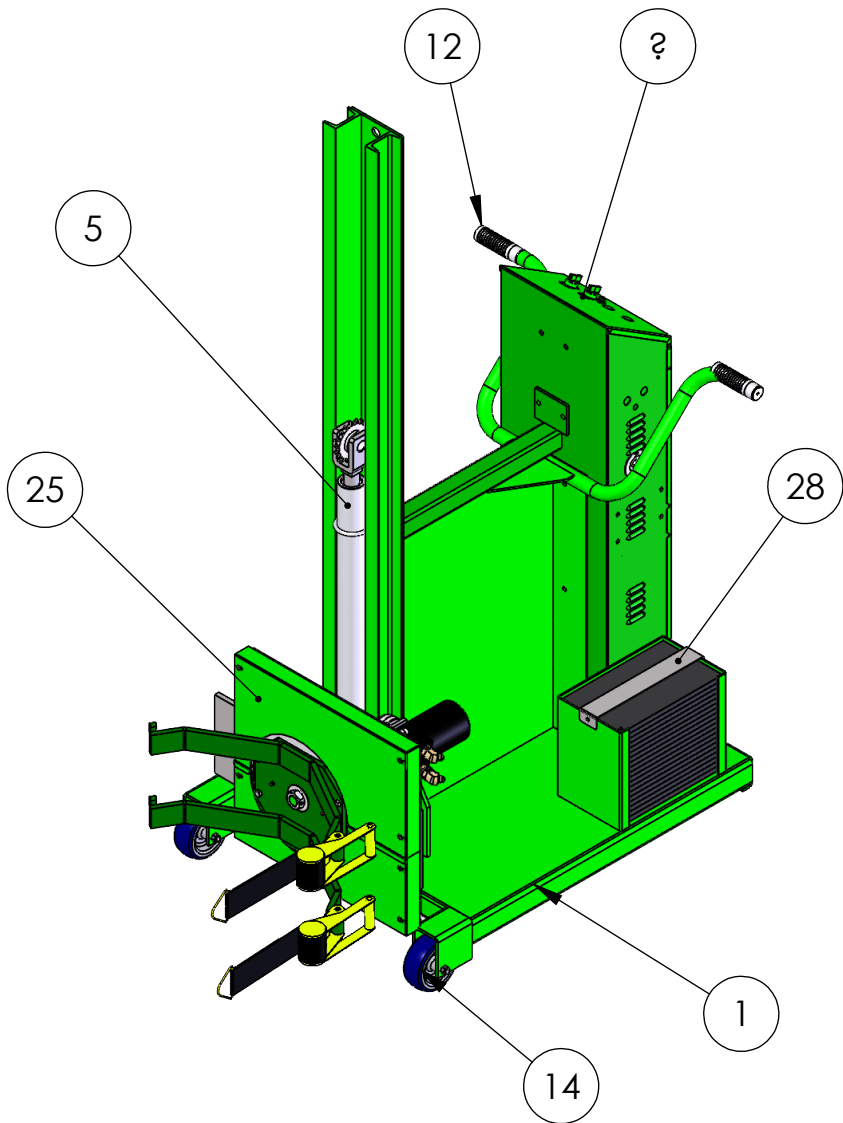

ROTOLIFT-78 BAT/CW SAE

ROTO Lift-78 12V DC BOM

*	ITEM NO.	PART NUMBER	DESCRIPTION	Def ault /QT Y.
	1	F64333A8	SL WLDMT-78 C/W ROTO	1
	2	F64367A4	BACK PL ASSY	1
*	3	GENERIC FLOOR	GENERIC FLOOR	1
	4	Z10132A9	S-HHC 3/8-16X1	2
	5	Z20753A0	CYL ASSY-78 SAE	1
	6	Z10113A2	S-HHC 1/4-20X1-1/4	2
	7	Z10043A7	NUT-NYL NE 1/4-20	2
	8	F52067A6	PIN-CLEVIS 1.00X2.375 (KANBAN)	1
	9	Z10072A1	PIN-SPG 1/4X1-1/2	1
	10	F63091A3	SPROCKET ASSY-50CT8 BRG 1.01 (purchased)	1
	11	Z30475A9	CSTR-4X2 SWL ELASTOMER	2
	12	Z50085A2	GRIP-HDL 1-1/4" BLK	2
	13	Z10241A7	BOLT-U 5/16-18 X 2-1/2	1
	14	Z30443A1	WHL-5 x 2 PAL	2
*	15	Z10458A5	S-HHC 1/2-13x3-1/2	2
	16	Z10393A3	NUT-LOCK 1/2-13	2
	17	F30152A8	LINK-RLR 50 B2 W/ATT DRLD (KANBAN)	1
	18	Z10123A0	S-HHC 5/16-18X1	8
	19	Z10036A6	NUT-HEX KEPS 5/16-18	8
	20	F63084A2	HOSE CHASE WLDMT	1
	21	F68730A0	PANEL ASSY ROTO-LIFT	1
	22	F58825A8	FRT-CTRL BOX	1
	23	Z20810A3	HARNESS-PUMP -/POWER DRIVE	1
	24	F68725A5	CTRL BOX ASSY/SL MOD	1
	25	F69299A4	FRT SECT ASSEMBLY/ROTOLIFT	1
	26	F57496	CHAIN SPACER	1
	27	Z11690A5	S-SHC 1/4-20X1-1/2 GR8	4
	28	F57560	COVER-WGT BOX	2
*	28	Z10385A3	SPHTHC #8x3/8 LG	4
*	28	F64330A1	SL WLDMT-90 C/W ROTO	1
*	29	Z20754A9	CYL ASSY-90 SAE	1
*	30	F61446A9	BATTERY-12V 80AH SEALED LEAD	1
	32	F53397A5	WGT	38

ROTOLIFT-78 BAT/CW SAE

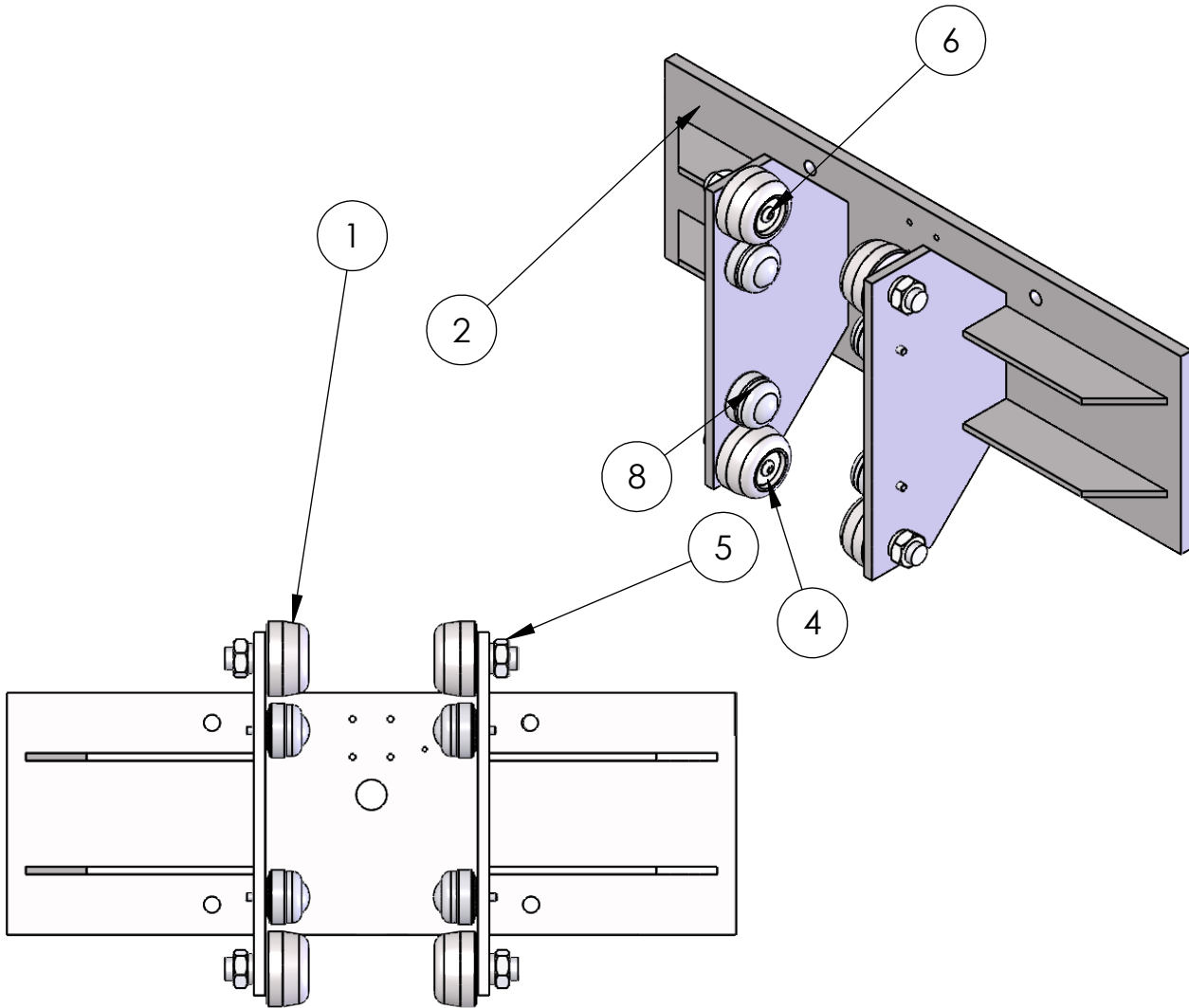

ITEM NO.	PART NUMBER	DESCRIPTION	Default/ QTY.
1	F64056A3	GUIDE RLR-BRG ASSY	4
2	F64335A6	BACK PL WLDMT	1
3	Z10008A0	BUSH-MACH 6H 3/4x18Gax1-1/4 OD	4
4	Z10042A8	WASHER-5/16 FNDR X 1-1/4 OD	8
5	Z10461A0	NUT-HEX JAM 3/4-16	4
6	Z10539A9	S-BHSC 5/16-18x3/4	4
7	Z10594A0	WASHER-3/4 LOCK MD	4
8	Z30700A8	BALL TRANSFER-STUD MNT 1/4-20	4
9	Z51355A9	GUIDE BOLT-3/4-16 1.00X1.14	4

ROTOLIFT-78 BAT/CW SAE

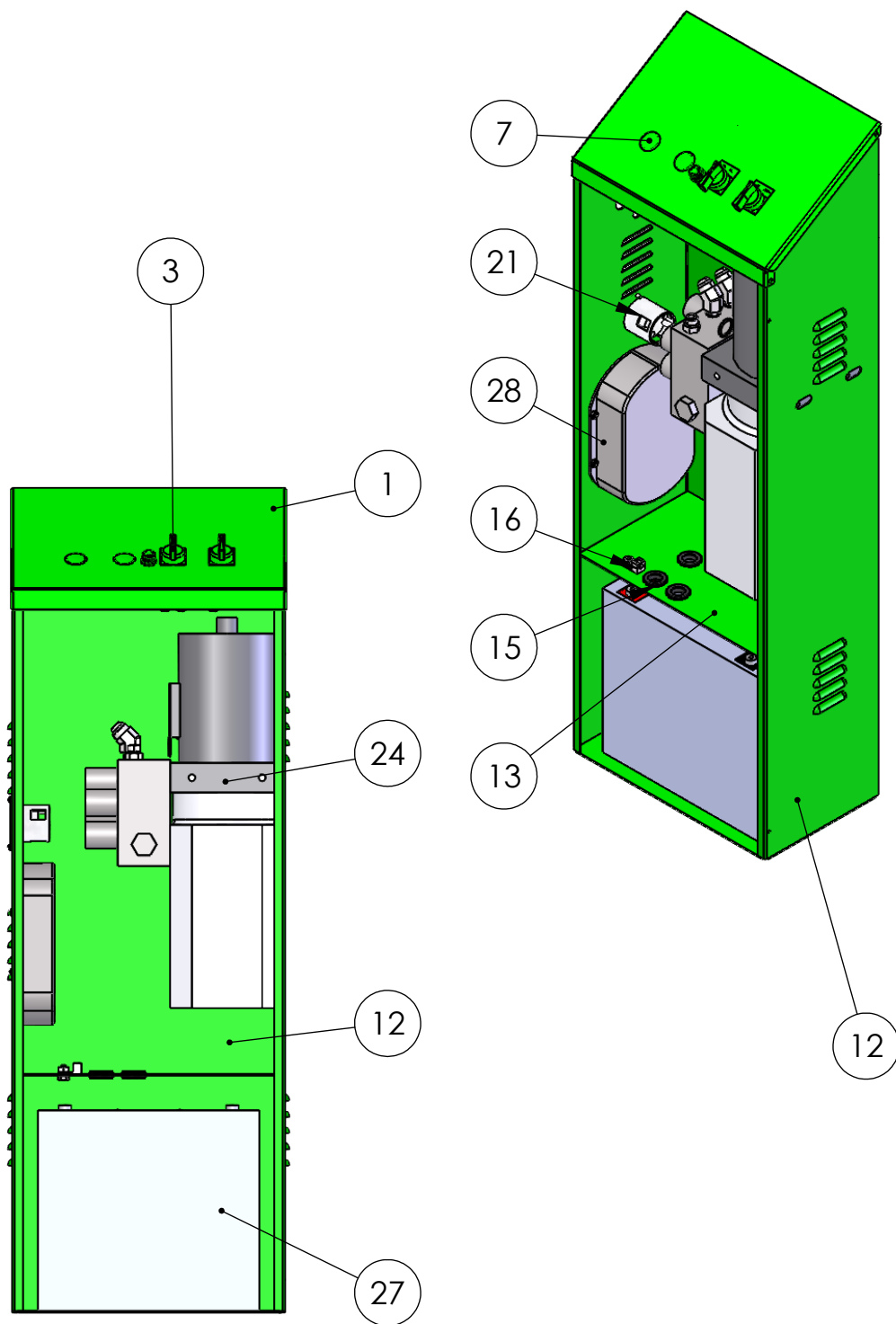

ROTOLIFT-78 BAT/CW SAE

ITEM NO.	PART NUMBER	DESCRIPTION	QTY.
1	F58824A7	TOP-CTRL BOX (KANBAN)	1
2	Z00463A9	BASE-ADH MNT 1 x 1	1
3	Z00523A7	SWITCH-3 POS MOM SPR RTN	2
4	Z00524A6	CONTACT BLOCK N/O	1
5	Z00526A4	LEGEND-22MM "UP/DOWN"	1
6	Z00527A3	LEGEND-22MM "LEFT-RIGHT"	1
7	Z50427A9	HOLE PLUG-1 X 16GA TU	2
8	Z00530A0	FUSE HOLDER PANEL MNT	1
9	Z00542A8	CONTACT BLOCK 2 N/O	3
10	Z00543A7	FUSE-AGC 25 AMP	1
11	F58825A8	FRT-CTRL BOX	1
12	F58826A9	ENCL-CTRL BOX WLDMT (KANBAN)	1
13	F58827A0	DVDR-CTRL BOX WLDMT	1
14	F58828A1	BTM-CTRL BOX WLDMT	1
15	Z00116A0	GROMMET-.625ID SBR	3
16	Z10708A3	LUG-SET SCREW 1/4	1
17	Z10109A8	S-HHC 1/4-20X1/2	1
18	Z10385A3	S-PTHTC #8x3/8 LG	2
19	Z10207A9	WASHER-1/4 LOCK INT TOOTH	1
20	Z10035A7	NUT-HEX KEPS 1/4-20	1
21	Z00120A4	PLUG-FLGD INLET 125V	1
22	Z20661A1	MANIFOLD-4SOL/3PORT 12V	1
23	Z20015A0	FTG 45 6802-4-6	2
24	Z20658A4	PP-BASE/12V	1
25	Z20107A9	O'RING-ARP116	1
26	Z20597A5	FTG STR 6400-4-6-O	1
27	Z00172A5	BATTERY-12V 80AH SEALED LEAD	1
28	Z20361A1	BATTERY CHARGER, DELTRAN 24v	1
29	Z10463A8	S-PTHM #8-32x3/8	4
30	F53397A5	WGT	1

ROTOLIFT-78 BAT/CW SAE

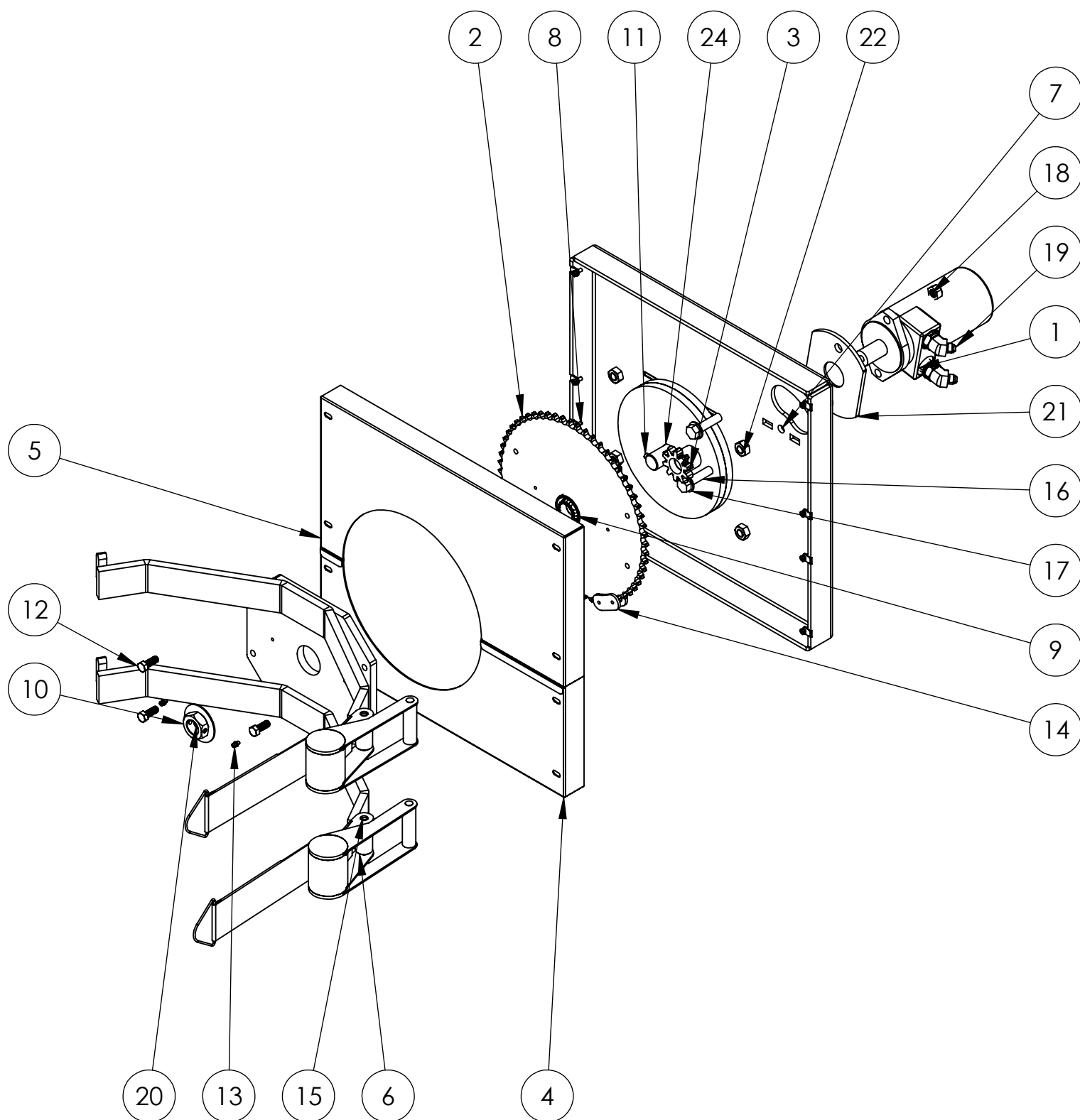

ROTOLIFT-78 BAT/CW SAE

ITEM NO.	PART NUMBER	DESCRIPTION	QTY.
1	Z20656A6	MOTOR-HYD/SAE	1
2	F52650A9	SPROCKET-LARGE	1
3	Z30400A2	SPROCKET-SM W/SHS	1
4	F57633	BTM SPROCKET GUARD/ROTOLIFT	1
5	F57632	TOP SPROCKET GUARD/ROTOLIFT	1
6	F62629A6	FRT SECT WLDMT/ROTO	1
7	F69433A9	BACK SECTION WLDMT/ROTO- LIFT	1
8	Z10166A8	S-HHTC #10-24X1/2	8
9	Z30420A8	BRG-TAPER ROLL 1"BOR	1
10	F52527A0	NUT-LOCK 1-14/DT (KANBAN)	1
11	Z10090A9	S-SHS 5/16-18X3/8	2
12	Z10132A9	S-HHC 3/8-16X1	4
13	Z10627A7	ZERK-GREASE .188 DRIVE	2
14	F30214A4	CHAIN-RS 50/46" (PURCH)	1
15	F62980A9	RATCHET ASSY-2.0X53.00 7000	2
16	Z10620A4	S-HHC 1/2-13X2 GR 5	2
17	Z10331A8	WASHER-1/2 FLAT SAE	2
18	Z10048A2	NUT-NYL NE 1/2-13	2
19	Z20891A6	FTG 45 6802-6-10 NWO	2
20	Z10013A3	WASHER-1 ID X 2-7/16 X 5/64	1
21	F57403	MOTOR MOUNT PLATE	1
22	Z10640A3	S-HHC 1/2-13X1-1/4 GR 5	4
23	Z10216A8	WASHER-1/2 LOCK MD	4
24	F57491	SPACER PLATE-1/2X 8-1/2RD	1

HYDRAULIC POWER UNIT

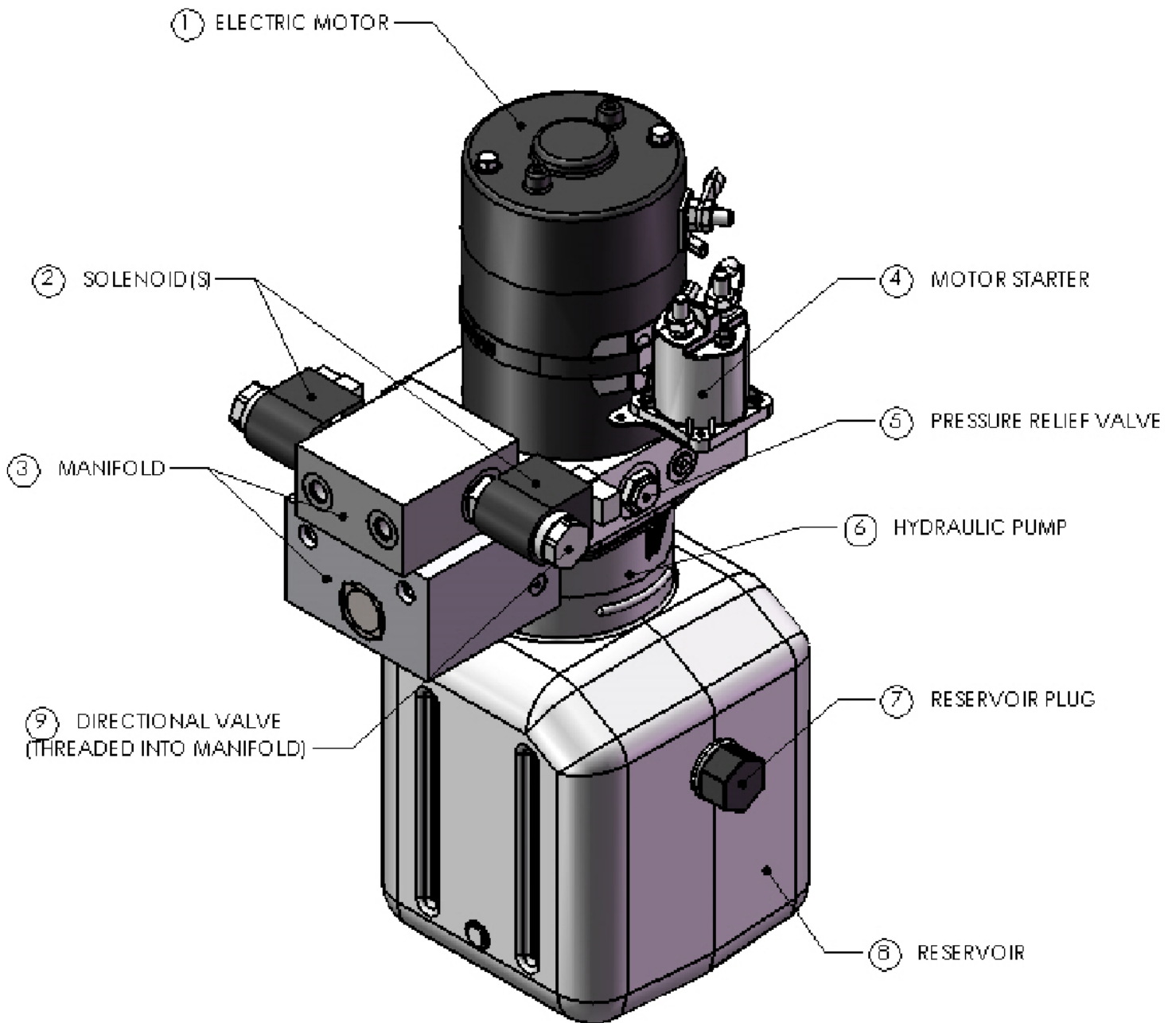

HYDRAULIC POWER UNIT SHOWN FOR REFERENCE ONLY; YOUR ACTUAL UNIT MAY VARY. FOR QUESTIONS, PLEASE CONTACT VALLEY CRAFT CUSTOMER SERVICE AT 1-800-328-1480 OR ON THE WEB AT [CUSTOMER@VALLEYCRAFT.COM](mailto:customer@valleycraft.com)

ROTOLIFT-78 BAT/CW SAE

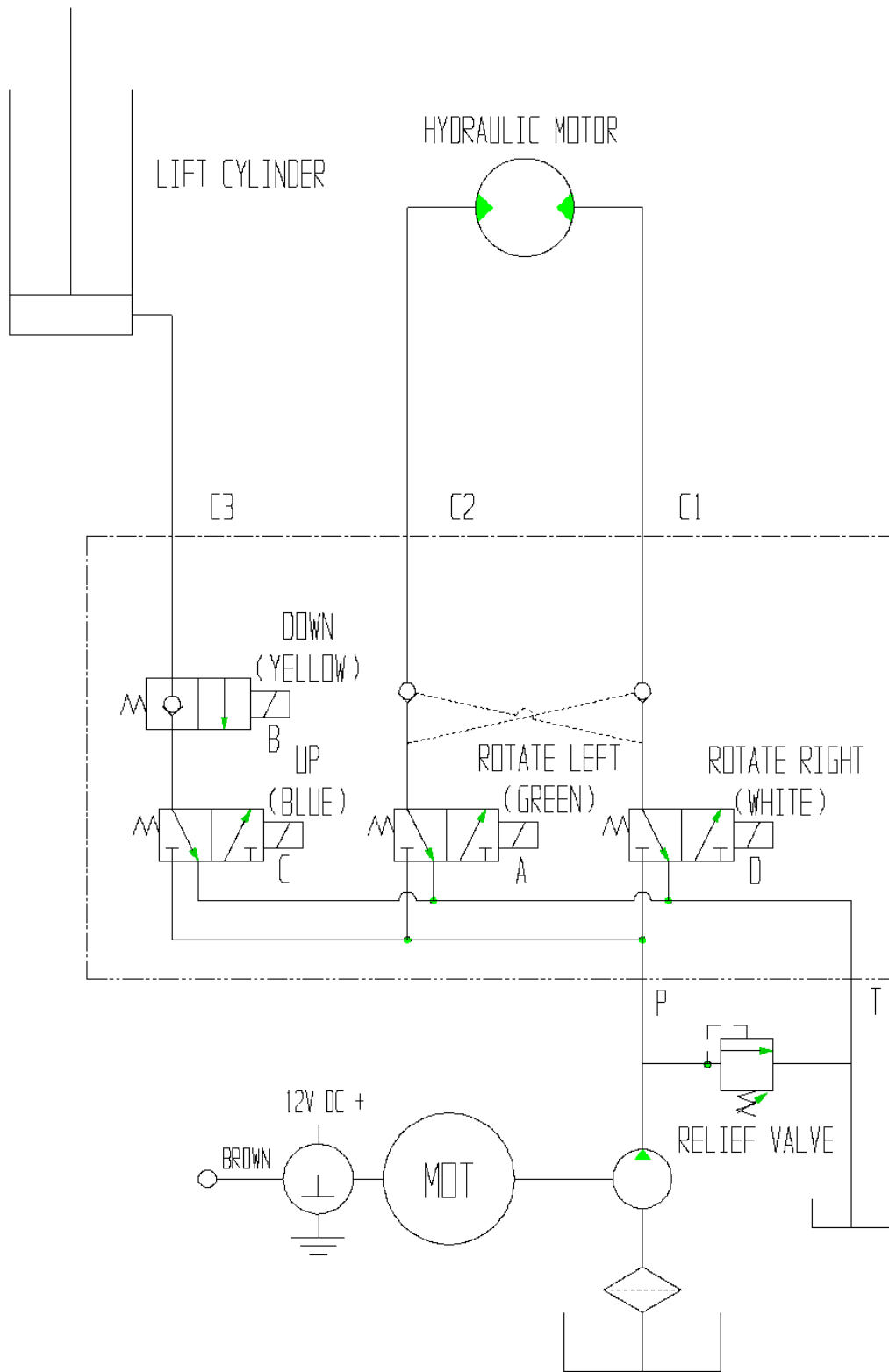

HYDRAULIC SCHEMATIC

ROTOLIFT-78 BAT/CW SAE

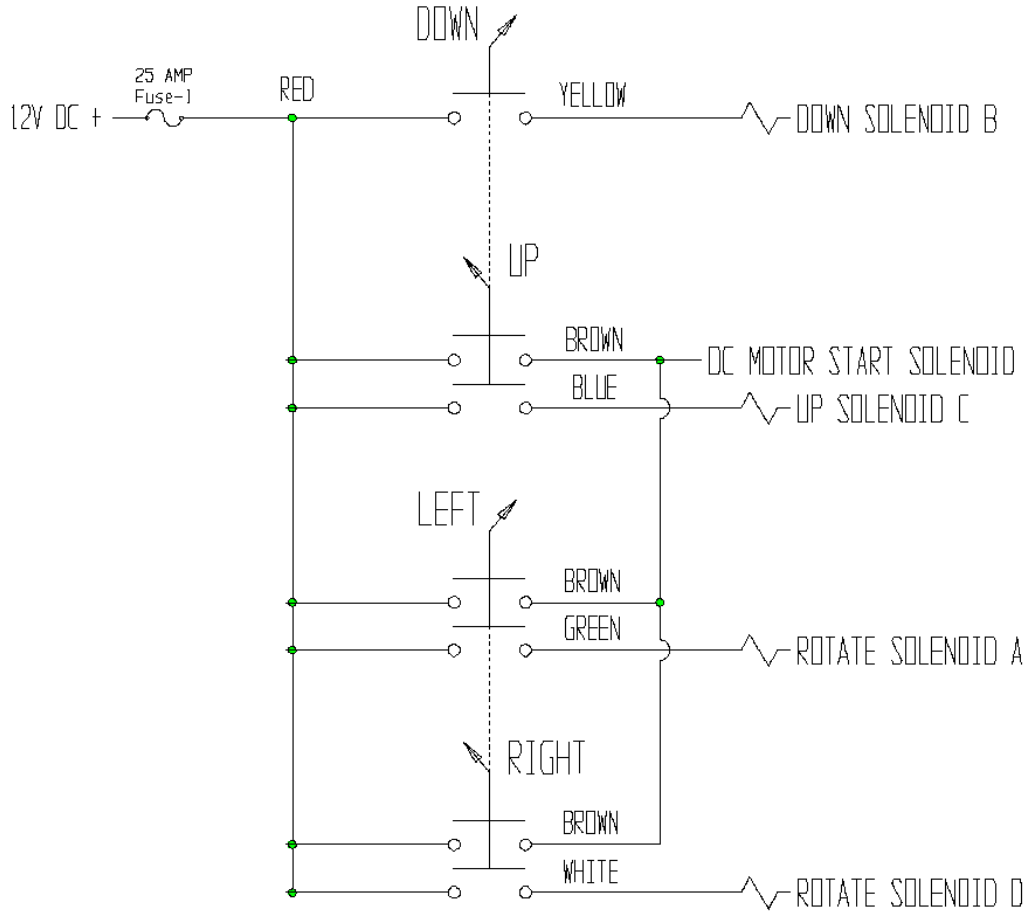

ELECTRICAL WIRING

Warranty and Limitation of Liability

Valley Craft products are warranted for a period of one (1) year from date of shipment from Valley Craft's plant to be free from defects in material and workmanship under correct use, normal operation and proper application. However, parts of other than Valley Craft manufacture are subject ONLY to the original manufacturer's warranty. Valley Craft's obligation under warranty shall be limited to repair or exchange, at Valley Craft's option, FOB origin factory, of any Valley Craft product or part which proves to be defective as provided herein. Valley Craft reserves the right to either inspect the product at Buyer's location, or require it to be returned to the factory for inspection. The warranty contained herein does not extend to goods damaged, or subject to accident, abuse or misuse after shipment from Valley Craft's factory, nor to goods altered or repaired by anyone other than an authorized Valley Craft representative.

Buyer or user shall not alter, modify or use a Valley Craft product for anything other than its intended function. Valley Craft shall not in any way be responsible for the consequences of any such alteration, modification or misuse.

VALLEY CRAFT MAKES NO EXPRESS WARRANTIES OTHER THAN THOSE WHICH ARE SPECIFICALLY DESCRIBED HEREIN. Any description of the goods sold hereunder, including any references to Buyer's specifications and any descriptions in catalogs, circulars and other written material published by Valley Craft, is for the sole purpose of identifying such goods and shall not create an express warranty that the goods shall conform to such descriptions.

THIS WARRANTY IS EXPRESSLY IN LIEU OF ALL OTHER WARRANTIES, EXPRESS OR IMPLIED. THERE ARE NO IMPLIED WARRANTIES OF MERCHANTABILITY OR FITNESS FOR A PARTICULAR PURPOSE. THIS WARRANTY STATES VALLEY CRAFT'S ENTIRE AND EXCLUSIVE LIABILITY AND BUYER'S EXCLUSIVE REMEDY FOR ANY CLAIM OR DAMAGES IN CONNECTION WITH VALLEY CRAFT PRODUCTS, THEIR DESIGN. SUITABILITY FOR USE, INSTALLATION OR OPERATION OR FOR ANY CLAIMED DEFECTS. VALLEY CRAFT WILL IN NO EVENT BE LIABLE FOR INCIDENTAL OR CONSEQUENTIAL DAMAGES WHATSOEVER, NOR FOR ANY SUM IN EXCESS OF THE PRICE RECEIVED FOR THE GOODS FOR WHICH LIABILITY IS CLAIMED.

Technical Assistance/Warranty Procedure

What's Covered:

- Parts and Labor to correct manufacturer's defect within one year of purchase.
- Freight Cost

What's Not:

- Normal wear items (seal kits, bearings, tires, etc.)

What Voids the Warranty:

- Dirt/Grime that directly causes malfunction of product
- Abuse (i.e. Overloading, damaged, not properly maintained, etc.)
- Product altered by customer

*See "Items not Under Warranty" below for items that have the warranty voided.

Items Under Warranty (less than one year old):

- Warranty replacement parts are provided only when the problem can be identified with near certainty. If not, the customer will return item to Valley Craft, freight collect, for troubleshooting and/or repair. When repaired, product will be returned to customer,



Valley Craft is a modern metals fabricating manufacturer specializing in material handling, storage and specialized solutions designed with safety and usability in mind, and the simplification of even the heaviest of workloads. Since developing the first hand truck with a brake in 1952, Valley Craft has been a true pioneer in safety-conscious material handling and solution-driven products. Our commitment to continuous improvement in a Lean Manufacturing environment results in safe, functional, quality equipment at affordable prices.

Valley Craft Industries, Inc.
2001 South Highway 61
Lake City, MN 55041 U.S.A.

Phone: (651) 345-3386

Fax: (651) 345-6535

E-Mail: customerservice@valleycraft.com

Website: valleycraft.com