

C/W ROTOLIFT BATTERY POWERED



INSTRUCTION MANUAL

VALLEY CRAFT, INC. 2001 SOUTH HWY. 61, LAKE CITY, MN 55041 PH: 1-800-328-1480

Last Updated 11/10

Z41966A6

TABLE OF CONTENTS

A.	OPERATING INSTRUCTIONS	PG. 3
B.	SAFETY & MAINTENANCE INFORMATION	PG. 4
C.	MAINTENANCE INFORMATION	PG. 4
D.	MSDS	PG. 4
E.	BATTERY CHARGING INSTRUCTIONS	PG. 5
F.	PARTS DIAGRAM	PG. 6-7
G.	CONTROL BOX PARTS	PG. 8
H.	FRONT SECTION ASSEMBLY PARTS	PG. 9-10
I.	PANEL ASSEMBLY	PG. 11
J.	HYDRAULIC/ELECTRICAL SCHEMATIC	PG. 12
K.	TROUBLESHOOTING CHART	PG. 13
L.	WARRANTY STATEMENT	PG. 14

A. Operating Instructions

NOTE: IT IS RECOMMENDED THAT ALL OPERATORS FAMILIARIZE THEMSELVES WITH THE MACHINE AND DEVELOP SAFE WORKING HABITS.

1. **IMPORTANT!** Remove solid plug on hydraulic reservoir and install breather cap (included in the Power Pak) for proper air venting.
2. Install battery with the negative pole on the left hand side (do not allow ground wire to come in contact with any other wires or a short will occur).
3. Loosen rotator straps in the following way. A) Depress “finger release” on ratchet and fold handle open. B) Pull strap through ratchet just far enough to unhook metal ring from T-bar at the end of the rotating arm. C) Perform this on both ratchets.
4. Move the Roto-Lift forward, straddling the drum, and center the rotating arms to the drum using the “up/down” switch on the control box panel.
5. After arms are centered on drum, push unit forward the rest of the way so the drum touches the rear of the rotating arms.
6. Pull both straps around the front of the drum and hook the metal ring onto the T’bar on the end of the rotating arms.
7. By depressing the “finger release” on the ratchet and returning it to the original position, you may now ratchet the straps tight around the drum.
8. With **BOTH** straps tight, raise the drum by using the “up” function switch.
9. To dump, raise the drum to the desired height and rotate the switch on the control box panel the direction you want the drum to dump.

B. Safety Instructions

1. When transporting a load, it is recommended that the attachment is lowered as close to the floor as possible to reduce the chances of accidents during transport.
2. Do not leave load suspended for an extended period of time or premature wear to the lifting cylinder will occur.
3. Maximum lifting capacity is 800 pounds.

C. Maintenance Information

1. Use 12 Volt 80AH sealed lead acid AGM battery. Approximate dimensions of the battery is 10 ¼ long x 6 ¾ wide x 8 3/8 high (to top of terminal). Battery warranty is free replacement within one year of purchase.
2. Check hydraulic fluid every 40 hours or before using the machine after long set-aside periods. Three quarts of hydraulic fluid is sufficient to operate the system properly. Do no overfill. Use Dexron automatic transmission fluid only!
3. The lifting chain should be oiled periodically as needed. This is best accomplished by lowering the backplate completely and spraying lubricant onto the chain.
4. Check nylon straps occasionally for wear and replace as necessary.

D. MATERIAL SAFETY DATA SHEETS (MSDS)

A Material Safety Data Sheet (MSDS) provides information on the safe use, handling and potential hazards of a product. This information assists with the proper response in the event of an emergency.

Valley Craft maintains material safety data sheets (MSDS) on all our products. You are urged to obtain copies of the relevant MSDSs before using our products to protect yourself and others against any known health or safety hazards described in these MSDSs. Valley Craft strives to make safety a top priority. Do not hesitate to contact us to discuss any safety aspects of our products.

The relevant MSDS codes for Valley Craft products are listed below.

www.conocophillips.com

Super ATF Transmission Oil, MSDS Code 778846

Super-Sta Grease, MSDS Code 775440

www.batteriesplus.com

Sealed Lead Acid Battery

SLA for English version

SLA Sp for the Spanish version

[Paint](#)

Contact Valley Craft Customer Services at 1-800-328-1480 or on the web at customer@valleycraft.com

E. Battery Charging Instructions

1. Plug a grounded extension cord into built-in receptacle in Control Box and plug into outlet.
2. The RotoLift is charged automatically, and can be left unattended while charging.
3. When re-charging is accomplished, unplug extension cord from Control Box.

NOTES:

- A. Generally, batteries will require equal charging to work time (ex. One hour of machine use = one hour of re-charging time).
- B. It is not recommended that alternate charging devices be used.
- C. **CAUTION!** To avoid shock or burn, **NEVER** touch the unit while recharging.

PARTS BREAKDOWN
F88569C3 ROTOLIFT-78 CW
F88570C0 ROTOLIFT-90 CW

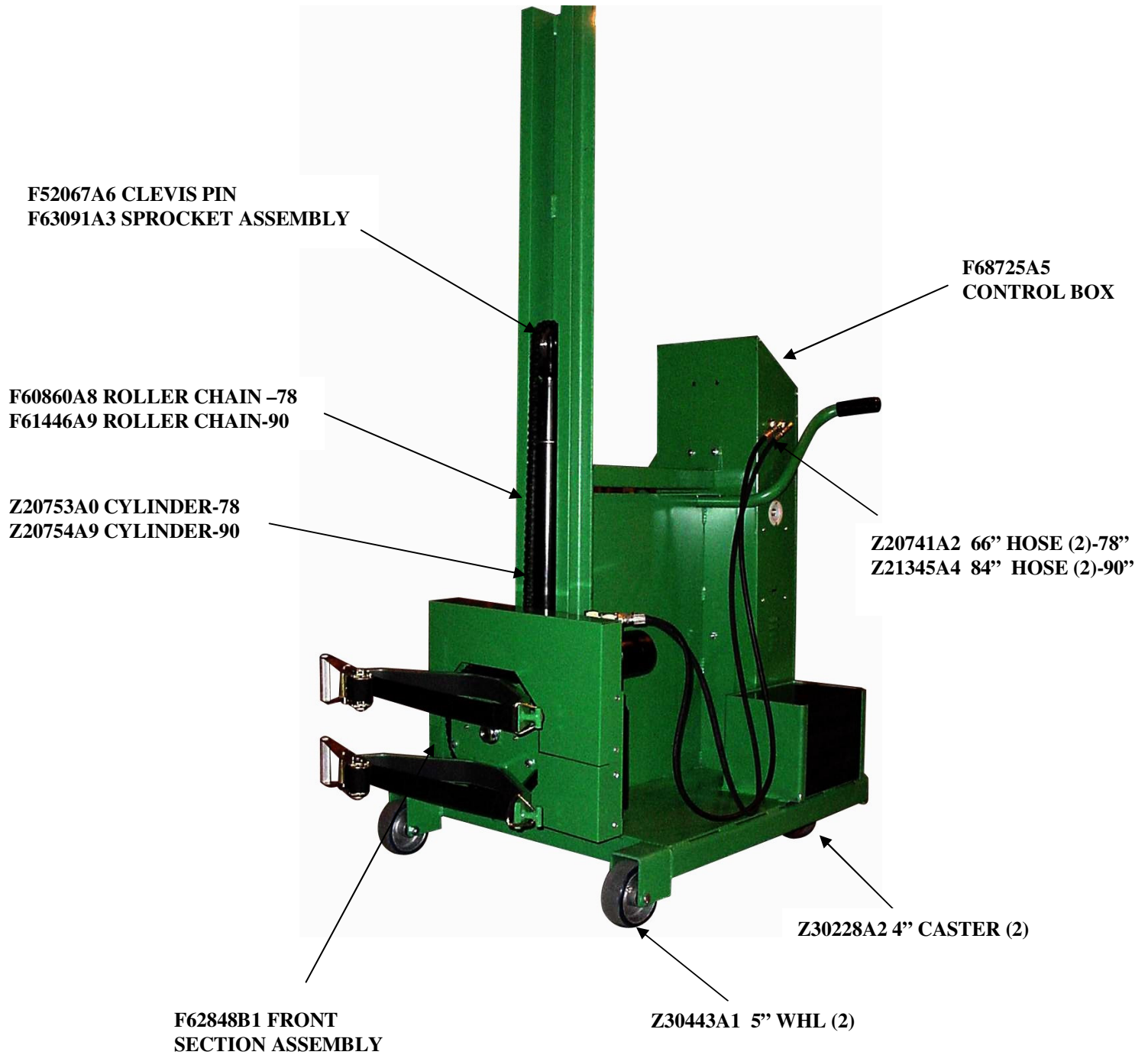

BACKPLATE ASSEMBLY
F64367A4

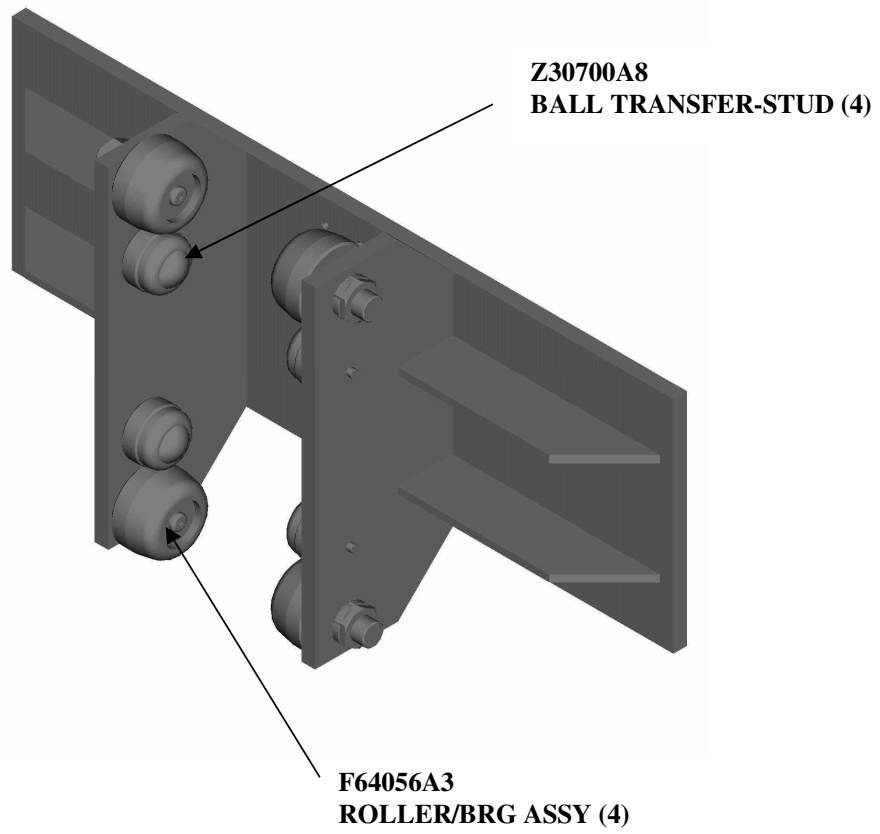

CONTROL BOX ASSEMBLY
F68725A5

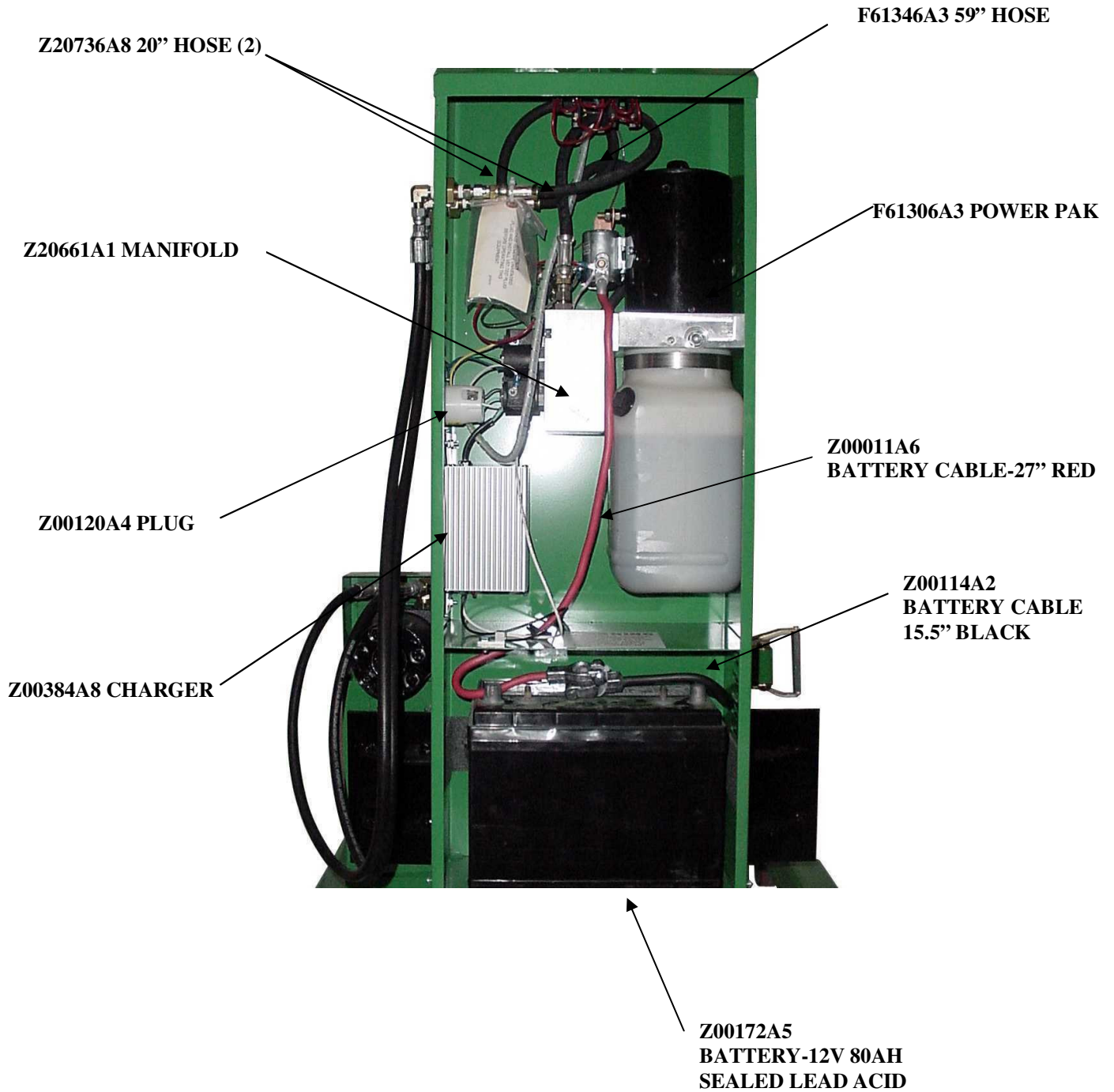

PARTS BREAKDOWN
FRONT SECTION ASSEMBLY
F62848B1

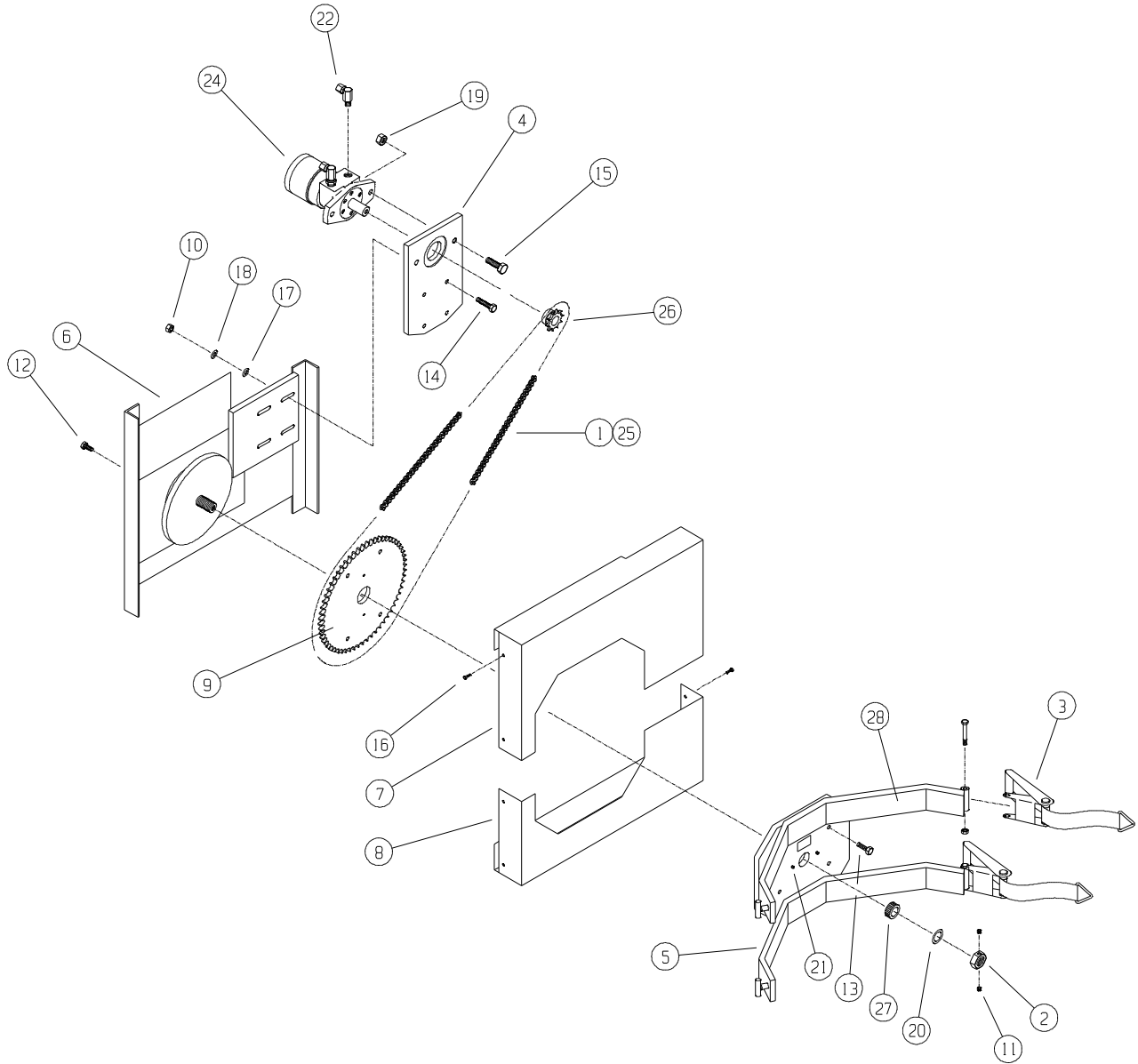

FRONT SECTION ASSEMBLY
PARTS LIST

ITEM	PART NUMBER	DESCRIPTION	QTY.
1	F30214A4	CHAIN-ROLLER	1
2	F52527A0	NUT-LOCK 1-1/4	1
3	F62980A9	RATCHET ASSY	2
4	F52651A8	MNT-MOTOR	1
5	F62629A6	FRT SECT WLDMT	1
6	F62630A3	BACK SECT WLDMT	1
7	F52648A4	GUARD-CHAIN TOP	1
8	F52649A3	GUARD-CHAIN BTM	1
9	F52650A9	SPROCKET-LARGE	1
10	Z10026A8	NUT-HEX JAM 3/8-16ZP	2
11	Z10090A9	S-SHS 5/16-18X3/8	2
12	Z10122A1	S-HHC 5/16-18X3/4	2
13	Z10132A9	S-HHC 3/8-16X1	4
14	Z10134A7	S-HHC 3/8-16X1-1/2	2
15	Z10148A1	S-HHC 1/2-13X1-1/2	2
16	Z10166A8	S-HHTC #10-24X1/2	8
17	Z10202A4	WASHER-3/8 FLAT	4
18	Z10214A0	WASHER-3/8 LOCK	8
19	Z10393A3	NUT-LOCK 1/2-13	2
20	Z10430A5	BUSH-MACH 1X14GAX2	1
21	Z10627A7	ZERK-GREASE .188	2
22	Z20701A3	FTG 90 6801-6-10 NOW	2
24	Z20656A6	MOTOR-HYD	1
25	Z30059A6	LINK-CONN SPT/CLIP	1
26	Z30400A2	SPROCKET-SM W/SHS	1
27	Z30420A8	BRG-TAPER ROLL 1" BORE	1
28	Z50037A1	RUBBER PAD	4.17'

TOP PANEL CONTROL BOX
F68730A0

UP/DOWN LEFT/RIGHT



Z00523A7
3-POSITION SWITCH

Z00524A6
CONTACT BLOCK N/O
(DOWN)

Z00542A8
CONTACT BLOCK 2 N/O
(UP)

Z00542A8
CONTACT BLOCK 2 N/O
(ROTATE LEFT)

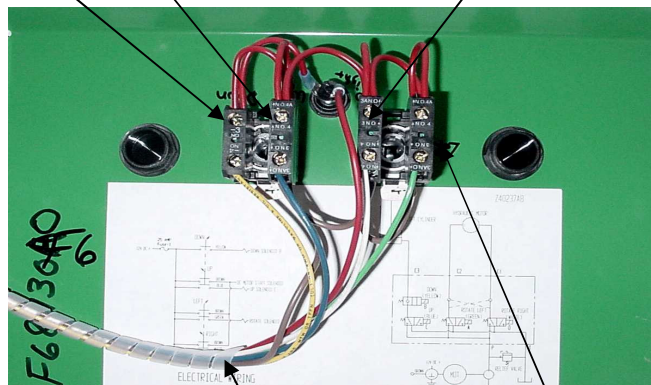

F68727A3
WIRE HARNESS

Z00542A8
CONTACT BLOCK 2 N/O
(ROTATE RIGHT)

HYDRAULIC/ELECTRICAL SCHEMATIC

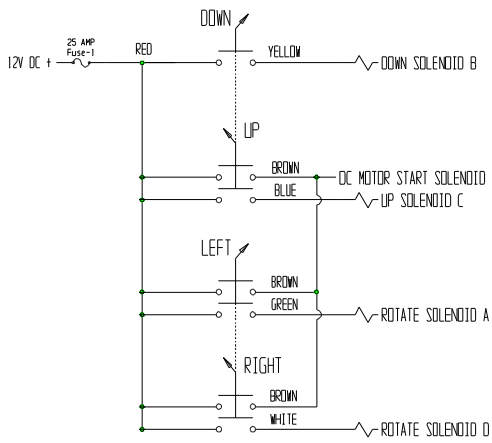

ELECTRICAL WIRING

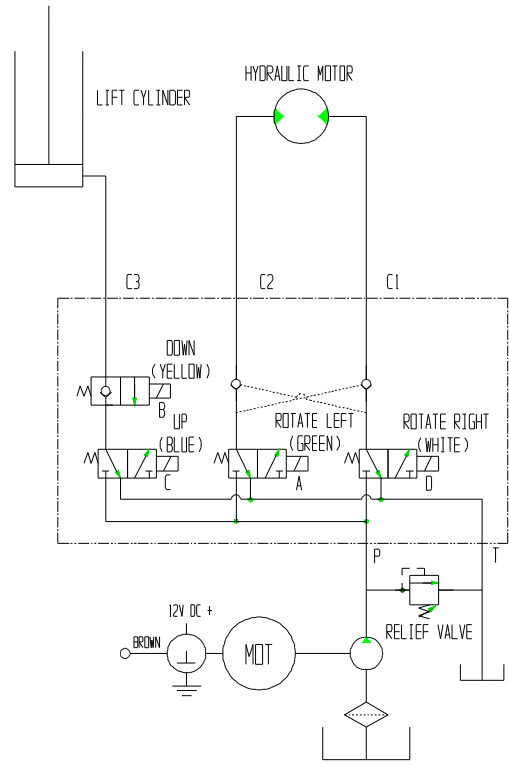

HYDRAULIC SCHEMATIC

TROUBLESHOOTING GUIDE

PROBLEM	POSSIBLE CAUSE	SOLUTION
Batteries won't charge	Faulty Battery(s)	Load test Batteries to ensure it is good. If Battery is bad see page 8 for replacement.
	Not following recharging directions	Refer to Battery Charging Instructions (Page 5)
	Improper grounding/wiring	Tighten Charger mounting bolts and check wiring
Unit not functioning	Low/Dead Batteries	Recharge Batteries
	Improper grounding	Check Motor & Battery wire connections. Tighten if necessary
	Damaged or loose wiring	Check wiring to switches in Control Box. Re-attach loose connections.
	Bad Switches	Call factory for replacement

Warranty & Limitation of Liability

Valley Craft products are warranted for a period of one (1) year from date of shipment from Valley Craft's plant to be free from defects in material and workmanship under correct use, normal operating and proper application. However, parts of other than Valley Craft manufacture are subject ONLY to the original manufacturer's warranty. Valley Craft's obligation under warranty shall be limited to repair or exchange, at Valley Craft's option, FOB origin factory, of any Valley Craft product or part which proves to be defective as provided herein. Valley Craft reserves the right to either inspect the product at Buyer's location, or require it to be returned to the factory for inspection. The warranty contained herein does not extend to goods damaged, or subject to accident, abuse or misuse after shipment from Valley Craft's factory, nor to goods altered or repaired by anyone other than an authorized Valley Craft representative.

Buyer or user shall not alter, modify or use a Valley Craft product for anything other than its intended function. Valley Craft shall not in any way be responsible for the consequences of any such alteration, modification or misuse.

VALLEY CRAFT MAKES NO EXPRESS WARRANTIES OTHER THAN THOSE WHICH ARE SPECIFICALLY DESCRIBED HEREIN. Any description of the goods sold hereunder, including any references to Buyer's specifications and any descriptions in catalogs, circulars and other written material published by Valley Craft, is for the sole purpose of identifying such goods and shall not create an express warranty that the goods shall conform to such descriptions.

THIS WARRANTY IS EXPRESSLY IN LIEU OF ALL OTHER WARRANTIES, EXPRESS OR IMPLIED. THERE ARE NO IMPLIED WARRANTIES OF MERCHANTABILITY OR FITNESS FOR A PARTICULAR PURPOSE. THIS WARRANTY STATES VALLEY CRAFT'S ENTIRE AND EXCLUSIVE LIABILITY, AND BUYER'S EXCLUSIVE REMEDY FOR ANY CLAIM FOR DAMAGES IN CONNECTION WITH VALLEY CRAFT PRODUCTS, THEIR DESIGN, SUITABILITY FOR USE, INSTALLATION OR OPERATION OR FOR ANY CLAIMED DEFECTS. VALLEY CRAFT WILL IN NO EVENT BE LIABLE FOR INCIDENTAL OR CONSEQUENTIAL DAMAGES WHATSOEVER, NOR FOR ANY SUM IN EXCESS OF THE PRICE RECEIVED FOR THE GOODS FOR WHICH LIABILITY IS CLAIMED.

Technical Assistance/Warranty Procedure

What's Covered:

- Parts and Labor to correct manufacturer's defect within one year of purchase.
- Freight Cost

What's Not:

- Normal wear items (seal kits, bearings, tires, etc.)

What Voids the Warranty:

- Dirt/Grime that directly causes malfunction of product
 - Abuse (i.e. Overloading, damaged, not properly maintained, etc.)
 - Product altered by customer
- *See "Items not Under Warranty" below for items that have the warranty voided.

Items Under Warranty (less than one year old):

- Warranty replacement parts are provided only when the problem can be identified with near certainty. If not, the customer will return item to Valley Craft, freight collect, for troubleshooting and/or repair. When repaired, product will be returned to customer, freight prepaid. Otherwise, customer may call local authorized service technician for assistance. Under this arrangement, replacement parts will be sent at no charge but labor costs will NOT be covered.

Items NOT Under Warranty (greater than one year old or *having warranty voided):

- Customer will return item to Valley Craft, freight prepaid, for troubleshooting and/or repair. Valley Craft will call customer with \$\$ estimate of parts and labor for approval before repairing. Product will be returned to customer, freight collect.

Or

- Customer may call local authorized service technician for repairs at their own expense.

Z4008 1A7



Valley Craft is a modern metals fabricating manufacturer specializing in material handling, storage and specialized solutions designed with safety and usability in mind, and the simplification of even the heaviest of workloads. Since developing the first hand truck with a brake in 1952, Valley Craft has been a true pioneer in safety-conscious material handling and solution-driven products. Our commitment to continuous improvement in a Lean Manufacturing environment results in safe, functional, quality equipment at affordable prices.

Valley Craft, Inc.

2001 South Highway 61
Lake City, Minnesota 55041 U.S.A.

Phone: (651) 345-3386

Toll Free: (800) 328-1480

Fax: (651) 345-3606

E-Mail: customer@valleycraft.com

Web: valleycraft.com • ovation-solutions.com
