

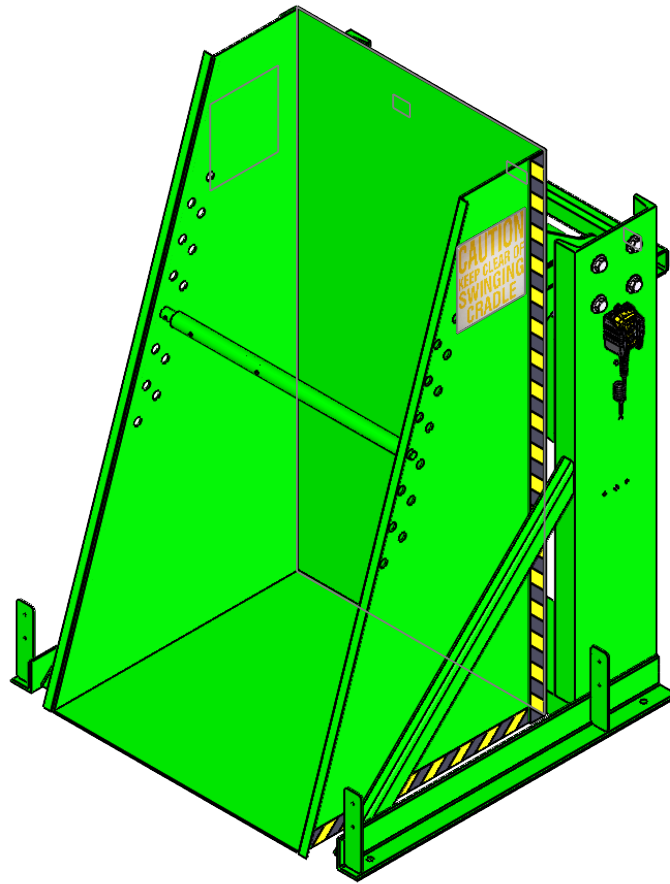

2000 LB. BOX DUMPER



HYDRAULIC BOX DUMPER

Notice to Purchaser

All statements, technical information, and recommendations related to Valley Craft's products are based on information believed to be reliable, but the accuracy or completeness is not guaranteed. Before using this product, you must determine if it is suitable for your intended application or situation. You assume all risks and liability associated with such use or implementation.

Product Testing

We perform vigorous in-house safety and durability testing to ensure that the performance of our products meets the demands of the workplace. We also expect the same from manufacturers who supply components for our products. We do this to ensure that Valley Craft is a name that our customers trust and associate with quality.

Publication Revision Notice

Following is a history of changes to this publication, including the current revision.

Previous Updated:

Last Updated: 07/2023

Copyright Notice

© Valley Craft, Inc. All rights reserved. No part of this publication may be reproduced, photocopied, stored on a retrieval system, or transmitted without the express written consent of Valley Craft.

Trademarks

The Valley Craft logo is a Valley Craft Trademark. All other company or product names are trademarks or registered trademarks of their respective owners. Use of a term in this document should not be regarded as affecting the validity of any trademark or service mark.

HYDRAULIC BOX DUMPER

■ Table of Contents

Safety	4-6
• Safety Overview	4
• Safety Message Conventions.....	5
• Safety Data Sheet	6
Product Description	7
• Specifications	7
• Features	7
Unpacking and Assembly	8
• Receiving and Inspection	8
• Installation	8
Operation	9-10
• Operating Procedures	9
• Operating Tips.....	10
Maintenance and Adjustments	10
• Maintenance and Adjustment Procedures.....	10
Troubleshooting	11
• Troubleshooting Procedures	11
Replacement	12
• Replacement Procedures.....	12
Parts List	13-14
• Hydraulic and Electrical Components & BOM	13-14
Equipment Drawings	15-16
• Hydraulic Schematic.....	15
• Electrical Diagram	16

HYDRAULIC BOX DUMPER

Safety

Read and understand all safety information and become familiar with all safety symbols contained in this section before moving, operating or performing maintenance on this equipment.

■ Safety Overview

The following general safety precautions must be observed during all phases of operation, service, and repair of this equipment. Failure to comply with these precautions or with specific safety messages elsewhere in this manual may impair the protection provided by the equipment. Such noncompliance would also violate safety standards of design, manufacture, and intended use of the instrument.

- Observe all safety signs posted in your facility.
- Observe warnings, cautions, handling information, storage requirements and other information on all container labels.
- Wear safety glasses with side shields.
- Wear the proper protective clothing, gloves and other protective equipment before handling any chemicals.
- Group the containers for the move by Hazard Class. Do not move acids with toxics, or oxidizers.
- Use maximum care and good judgment in preventing accidents and injuries and seeking first aid.
- Report unsafe conditions, equipment, practices, and on-job injuries.
- Understand your supervisor's instructions. Ask questions if you do not know how to do the job safely.
- Do not engage in tasks which you believe might be unsafe without consulting your supervisor.
- Clean up the work area and equipment upon job completion.
- Before you start work on any electrical system or circuit, check all power sources to ensure that the system or circuit is de-energized.
- Know the hazardous or potentially hazardous substances you work with or are present in your work area. Review Safety Data Sheets (SDS) on these substances, or contact your supervisor.

HYDRAULIC BOX DUMPER

■ Safety Message Conventions

There are three types of safety notices that may be contained in this manual: **Danger**, **Warning** and **Caution** notices. These notices precede the procedural step or portion of text that presents the safety hazard.



DANGER

- **DANGER** indicates an imminently hazardous situation which, if not avoided, will result in death or serious injury. This signal word is to be limited to the most extreme situations.
-



WARNING

- **WARNING** indicates a potentially hazardous situation which, if not avoided, could result in death or serious injury.
-



CAUTION

- **CAUTION** indicates a potentially hazardous situation which, if not avoided, may result in minor or moderate injury. It may also be used to alert against unsafe practices
-

HYDRAULIC BOX DUMPER

■ Safety Data Sheets (SDS)

A Safety Data Sheet (SDS) provides information on the safe use, handling and potential hazards of a product. This information assists with the proper response in the event of an emergency.

Valley Craft maintains safety data sheets (SDSs) on all our products. You are urged to obtain copies of the relevant SDSs before using our products to protect yourself and others against any known health or safety hazards described in these SDSs. Valley Craft strives to make safety a top priority. Do not hesitate to contact us to discuss any safety aspects of our products.

The relevant SDS codes are listed below.

- www.conocophillips.com
Super ATF Transmission Oil, SDS Code 778846
Super-Sta Grease, SDS Code 775440
- www.batteriesplus.com
Sealed Lead Acid Battery
SLA for the English version
SLA Sp for the Spanish version
- [Paint](#)
Contact Valley Craft Customer Service at 1-800-328-1480 or on the
Web at customerservice@valleycraft.com

■ Additional Safety Information

As with any mechanical device, care must be taken during the installation, operation, and maintenance of the device in order to realize the maximum benefit from its ownership.

Note: All personnel involved in the use and maintenance of this device should be thoroughly familiar with the information contained in this manual. Furthermore, it is recommended that all personnel be given adequate instruction and a sufficient period of training in its actual use to insure safety of personnel and proper care of the equipment. It is suggested that the units be initially operated empty until becoming familiar with how the unit handles.

HYDRAULIC BOX DUMPER

Product Description

The **Hydraulic Box Dumper** is a heavy duty, all welded steel dumper to accommodate various types and container sizes. Dump heights of 36", 48", 60" and 72" are available.

■ Specifications

The Hydraulic Box Dumper specifications are shown in Table 1.

Table 1. Specifications

Dimensions	Model dependant
Weight	Model dependant
Load Capacity	2000 lbs.

■ Features

The Hydraulic Box Dumper offers many advanced features.

- Chute sizes available are 36"x36" or 51"x48" (WxD)
- Available in dump heights of 36", 48", 60", and 72"
- 45° dump angle
- 3/60/460V power unit (PU/GD)
- 2 HP motor / 2 GPM hydraulic pump
- 24V Pendant Control to raise & lower the chute
- Gravity down system with flow control to safely lower chute
- Adjustable hold down bar for various container heights
- Carbon steel construction with powder coat finish

HYDRAULIC BOX DUMPER

■ Receiving and Inspecting

When unpacking this equipment, inspect the equipment for damage or mishandling. If damage is noted, file a damage claim with the carrier within 24 hours and call Valley Craft at 1-800-328-1480. Do not attempt to use the equipment.

Compare the contents of the shipment with the bill of lading. Report any missing items to the carrier and to Valley Craft immediately.

■ Installation

Only authorized, properly trained personnel should be permitted to install this equipment.

- Clean the installation area after removing all steel strapping and the wooden skids on which the unit was shipped.
- Place the unit in the position in which it is to be installed. When moving the unit, make sure it is picked from under the base frame.
- Position the Box Dumper unit to provide safe overhead and horizontal operating clearances.
- Install anchors in stationary units, lagging the Box Dumper unit securely to the floor. (Make sure that the base mounting legs are fully supported along their entire length with shims or concrete grout). NOTE: Anchoring holes should be drilled using existing holes in the base legs as a template. (1/2" anchor bolt minimum)
- All units are pre-wired and supplied with 10 feet of power cord. Utilizing provisions of applicable electrical codes, connect to the appropriate power supply.
- Check the level of the hydraulic fluid by removing reservoir fill plug. Add if necessary. Fluid level should be $\frac{3}{4}$ of reservoir capacity. NOTE: Do not overfill reservoir.
- Raise and lower the unit several times for the full cycle without a load. Check for any interference problems with existing framework of floor structure. Check for leaks in the hydraulic connections that may have loosened during shipment. Also, check for any damages that may have occurred during shipment.
- **Read and comply with all instructions and recommendations prior to operating unit.**

HYDRAULIC BOX DUMPER

■ Operating Procedures

As with any mechanical device, care must be taken during the installation, operation, and maintenance of the device in order to realize the maximum benefit from its ownership.

All personnel who are involved in the use and maintenance of this device should be thoroughly familiar with the information contained in this manual. Furthermore, it is recommended that all personnel be given adequate instruction and a sufficient period of training in its actual use to insure safety of personnel and proper care of the equipment. It is suggested that the Box Dumper units be initially operated empty until the operator is familiar with the cycle sequence and operation of the controls.

The hydraulic powered Box Dumpers have been designed primarily for indoor applications. Please contact your local distributor with any further questions.

- Stabilize Box Dumper unit by following installation instructions before operation. Note: on portable units, be sure the floor lock is in the down position before attempting to lift a load.
- Position load into the center of the chute. **WARNING: DO NOT EXCEED MAXIMUM CAPACITY OF DUMP UNIT. CONSULT THE LOAD CAPACITY DECAL AFFIXED TO THE BOX DUMPER.**
- Stand clear of the chute and depress the “up” control to initiate the dump cycle.
- Release the “Up” control to stop the chute at that level. The chute will stop at the set dump height when the chute makes contact with the hard stop on the frame of the unit.
- Stand clear of the chute, and depress the “Down” control to lower the chute.
- Release the “Down” control to stop the chute at that level. The chute will stop when it contacts fully against the frame.
- When chute is completely lowered, remove the empty container and repeat the cycle as required.

HYDRAULIC BOX DUMPER

■ Operating Tips

- Always load the Box Dumper properly, centering the load into the chute as much as possible.
- The Box Dumper should be initially operated empty until the operator is thoroughly familiar with the cycle sequence and operation of the controls.
- Ensure that all personnel are clear of the chute before raising and lowering.
- Do not exceed the maximum load capacity rating. Consult load capacity decal affixed to the dump unit.
- Never use the Box Dumper if it is in need of repairs or in case of a malfunction.
- Notify your maintenance personnel in case of machine malfunction.
- Do not continue to depress the “Up” or “Down” control after the Box Dumper unit has reached the end of its travel or if the unit is not cycling. Damage could occur to the unit.

Maintenance and Adjustments

■ Maintenance and Adjustment Procedures

To keep this equipment operating properly, timely maintenance and adjustments are required. These procedures should be performed only by qualified personnel who are familiar with the equipment. Ensure dumper is disconnected from power and chute is in down position prior to inspecting and performing maintenance and adjustment procedures.

Maintenance and adjustment procedures are shown in Table 2.

Table 2. Maintenance and Adjustment Procedures

Component	Frequency	Operation	Procedure
Bearings / Pivot Points	Monthly	Grease	Apply grease as required
Hydraulic Fluid Level	Monthly	Visually inspect	Should fluid level become low or appear dirty or “milky”, replace fluid with Super ATF Transmission fluid. Fluid level should be approximately 1-1/2” below fill hole.
Structural components	Monthly	Visually inspect	Replace as required
Hydraulic System	Monthly	Visually Inspect	Inspect for leaks and damaged hydraulic lines and correct as required
Electrical System	Monthly	Visually Inspect	Inspect for damaged or frayed wires and correct as required

HYDRAULIC BOX DUMPER

Troubleshooting

■ Troubleshooting Procedures

If troubleshooting or maintenance should be required, it should be performed only by qualified personnel trained to perform such procedures. *Table 3. Trouble Shooting Procedures*

Problem	Possible Cause	Corrective Action
Motor Won't Start	<ol style="list-style-type: none"> 1. Loose connection 2. Circuit breaker tripped 3. Excess voltage drop 4. Seized pump 5. Tripped relay 	<ol style="list-style-type: none"> 1. Check motor/circuit wiring 2. Reset circuit breaker 3. Use larger gauge wire/closer plug-in 4. Replace pump 5. Replace relay
Will not pump oil (Motor runs but cylinder does not move, or moves slowly)	<ol style="list-style-type: none"> 1. No oil in reservoir 2. Motor rotation 3. Oil level low 4. Suction strainer is clogged 5. Cylinder piston seals are cut or worn 6. Reservoir breather is dirty or clogged 	<ol style="list-style-type: none"> 1. Check oil level, refill $\frac{3}{4}$ full 2. Rewire for motor direction (3ph only) 3. Add oil as needed 4. Clean/replace suction strainer 5. Replace/repair cylinder 6. Clean reservoir breather and reinstall
Pump motor unit is noisy	<ol style="list-style-type: none"> 1. Low oil level 2. Air in system 3. Suction strainer or inlet filter clogged 	<ol style="list-style-type: none"> 1. Add oil as needed 2. Bleed air from highest fitting in system by loosening fitting very slightly and operating unit until air is removed then tighten. 3. Clean suction strainer or inlet filter
Unit does not develop full pressure	<ol style="list-style-type: none"> 1. System relief valve set too low, or leaking 2. Pump worn out 3. Air in hydraulic system 4. Oil temperature is too high 	<ol style="list-style-type: none"> 1. Check system relief valve for proper setting with pressure gauge in outlet line 2. Replace worn parts or pump 3. Bleed air from hydraulic system 4. Let oil cool below 160°F
Unit does not raise or lower	<ol style="list-style-type: none"> 1. Motor rotation reversed 2. Faulty solenoid 3. Hydraulic valve clogged or blocked 4. Load exceeds capacity requirements 5. Flow control closed 6. Relief valve is set too low 	<ol style="list-style-type: none"> 1. Check motor wiring 2. Test solenoid 3. Remove and clean hydraulic valve 4. Check weight of load 5. Adjust flow control accordingly 6. Adjust Relief valve accordingly.

HYDRAULIC BOX DUMPER

Replacement

■ Replacement Procedures

Occasionally, it will be necessary to replace a part that has been Damaged or worn. Many parts on this product are replaceable. If Replacement of a part is required, it should be performed only by Qualified personnel who are familiar with the equipment.

See the following pages for available replacement parts. Identify the part number you need. Contact Valley Craft Customer Service at 1-800-328-1480 or on the Web at customerservice@valleycraft.com

Information required when contacting Valley Craft:

- A. Company name and address
- B. Contact persons name
- C. Telephone number
- D. E-Mail address
- E. Model Number
- F. Date of manufacture
- G. Part umber of Parts ordering

The model number and date of manufacture is stamped on a metal tag located on the frame by the switch.

HYDRAULIC BOX DUMPER

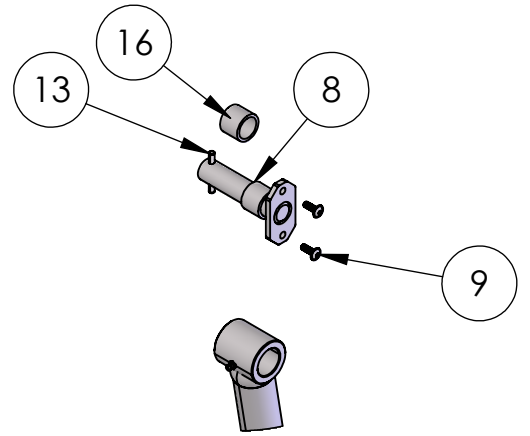
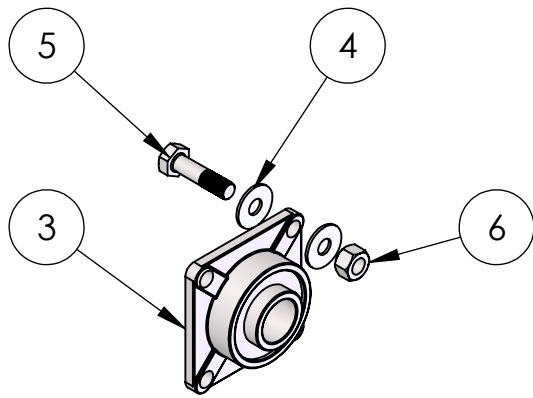

DETAIL B
SCALE 1 : 8

DETAIL A
SCALE 1 : 8

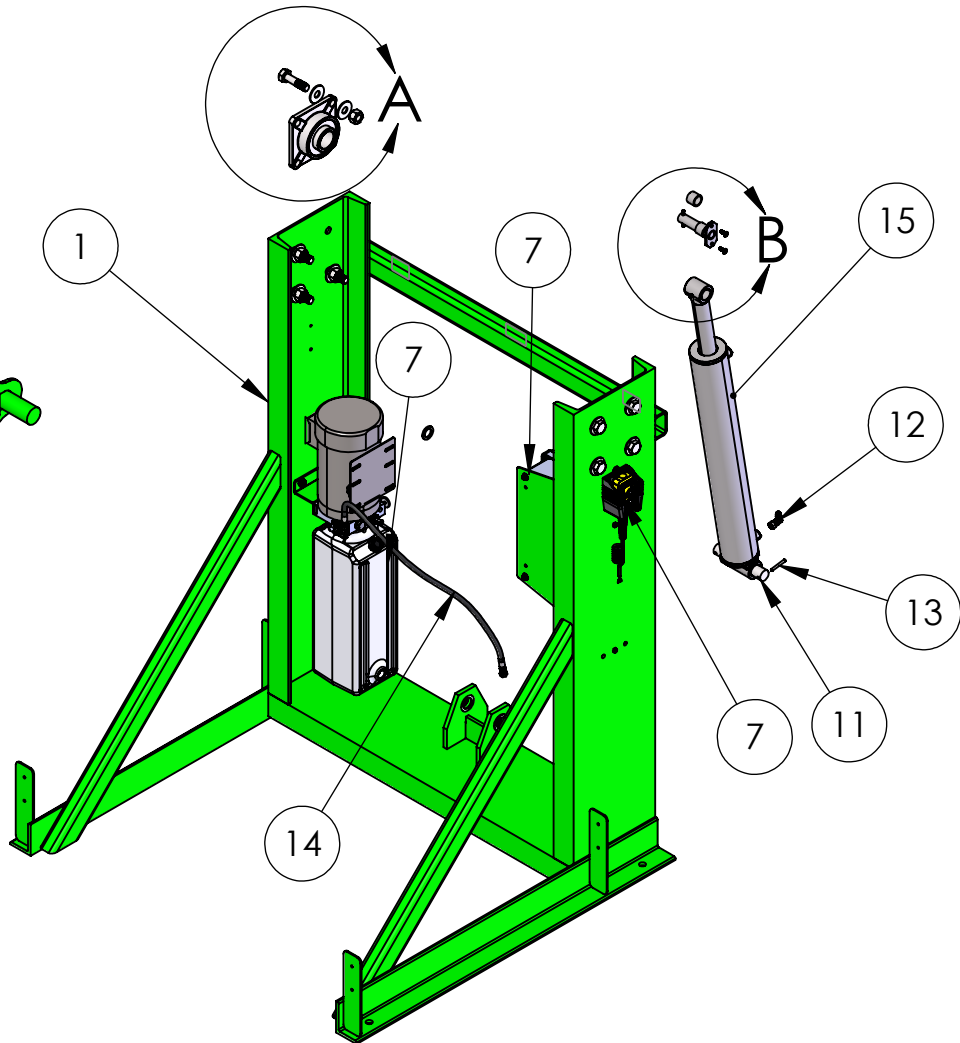
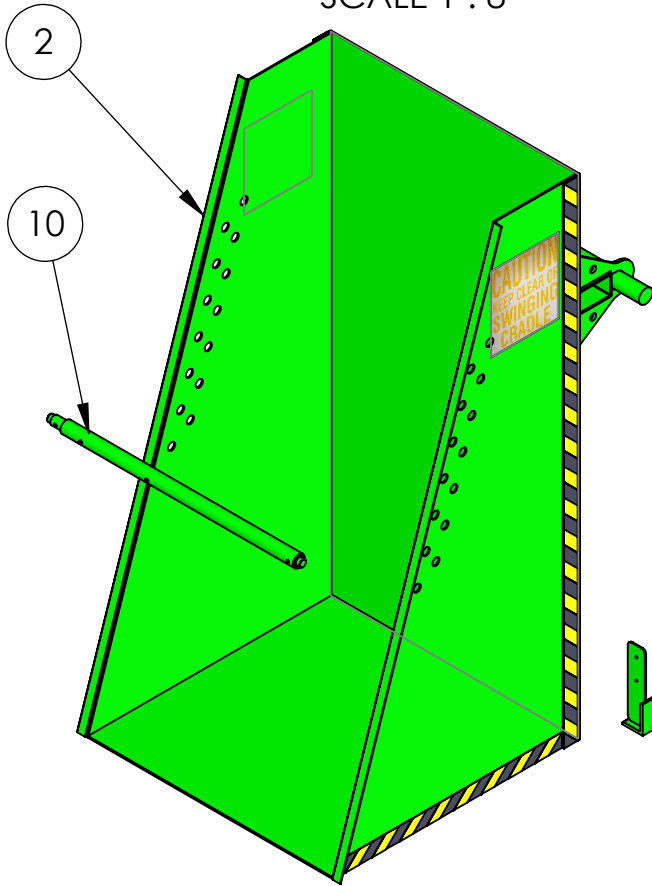

B D 36X36X72-48DH/2000# S VC 460V

ITEM NO.	PART NUMBER	DESCRIPTION	QTY.
1	F69536A9	FRAME WLDMT 36X36X36 DH 2K# BD	1
1	F69534A1	FRAME WLDMT 36X36X48 DH 2K# BD	1
1	F69532A3	FRAME WLDMT 36X36X60 DH 2K# BD	1
1	F69528A7	FRAME WLDMT 36X36X72 DH 2K# BD	1
2	F69537A8	CHUTE WLDMT 36X36X36 DH 2K# BD	1
2	F69535A0	CHUTE WLDMT 36X36X48 DH 2K# BD	1
2	F69533A2	CHUTE WLDMT 36X36X60 DH 2K# BD	1
2	F69528A7	CHUTE WLDMT 36X36X72 DH 2K# BD	1
3	Z30599A9	FLANGE 2 4BOLT	2
4	Z10395A1	WASHER-3/4 FLAT USS	16
5	Z10555A3	S-HHC 3/4-16 x 3	8
6	Z10394A2	NUT-NYLOCK 3/4-16	8
7	F69497A8	PU ASSY-3/60/460V PU/GD 1 CYL	1
7	F69549A6	PU ASSY-3/60/230V PU/GD 1 CYL	1
8	F69505A0	BD PIN WLDMT	1
9	Z11572A7	S-BHCS 1/4-20X3/4 ZINC	2
10	F69531A4	HLD DOWN TUBE ASSY/BD 36W	1
11	F54672A7	PIN-1 1/4DIAx6 7/8	1
12	Z20556A6	FTG 90 6500-6-6	1
13	Z10074A9	PIN-SPG 1/4X2	3
14	Z20743A0	HOSE-36.00/612	1
15	Z20949A4	CYL 3-1/2 X 1-3/4 X 24	1
15	Z20941A6	CYL 3-1/2 X 1-3/4 X 30	1
15	Z20948A3	CYL 3-1/2 X 1-3/4 X 20	1
16	F57773	CYLINDER BUSHING BD	2
29	Z10013A3	BUSH-MACH 1x10GAx1-1/2 OD	1
30	Z10592A2	BUSH-MACH 1-1/4X10GA ZP	4

HYDRAULIC POWER UNIT

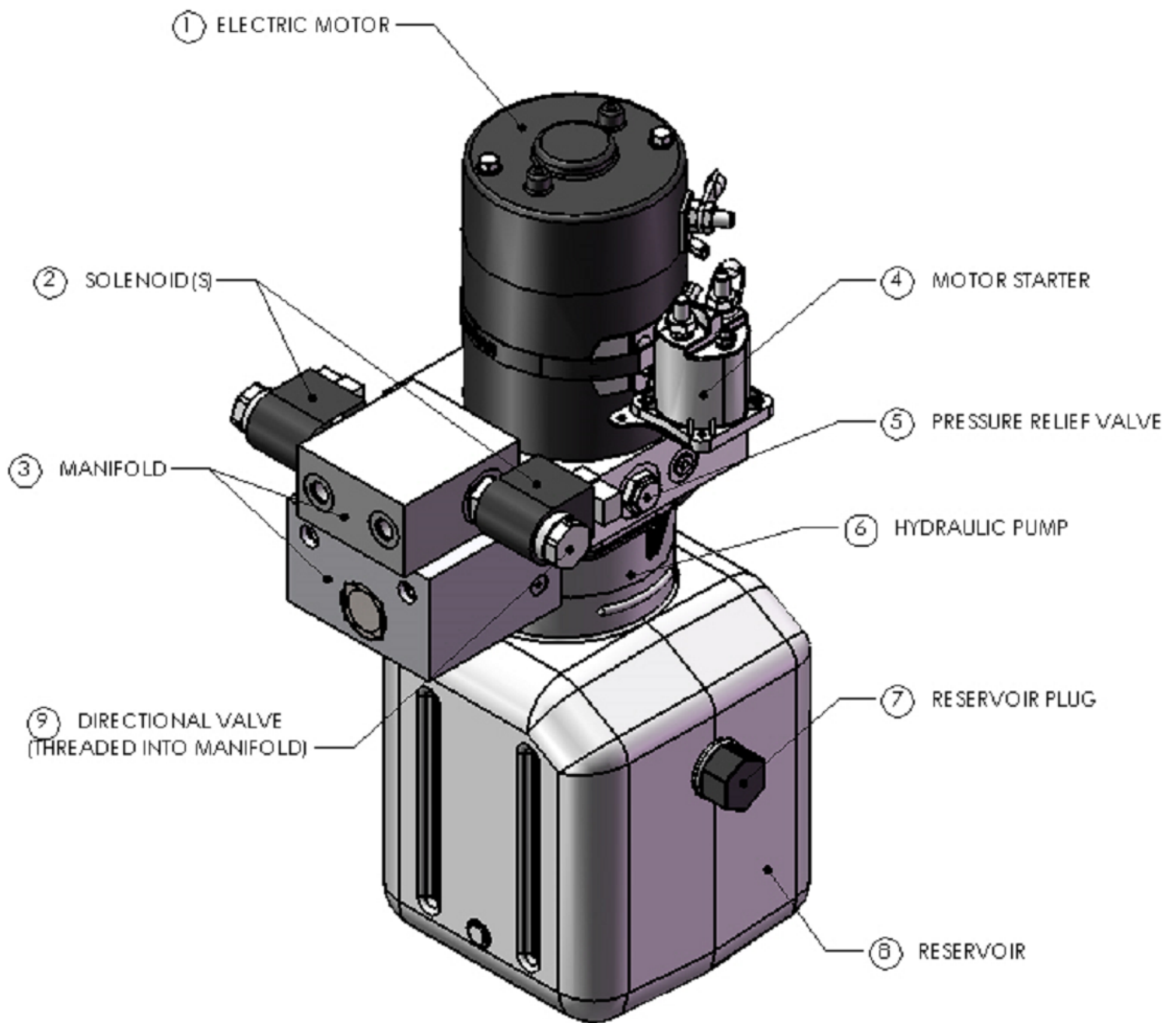

HYDRAULIC POWER UNIT SHOWN FOR REFERENCE ONLY; YOUR ACTUAL UNIT MAY VARY. FOR QUESTIONS, PLEASE CONTACT VALLEY CRAFT CUSTOMER SERVICE AT 1-800-328-1480 OR ON THE WEB AT CUSTOMER@VALLEYCRAFT.COM

HYDRAULIC BOX DUMPER

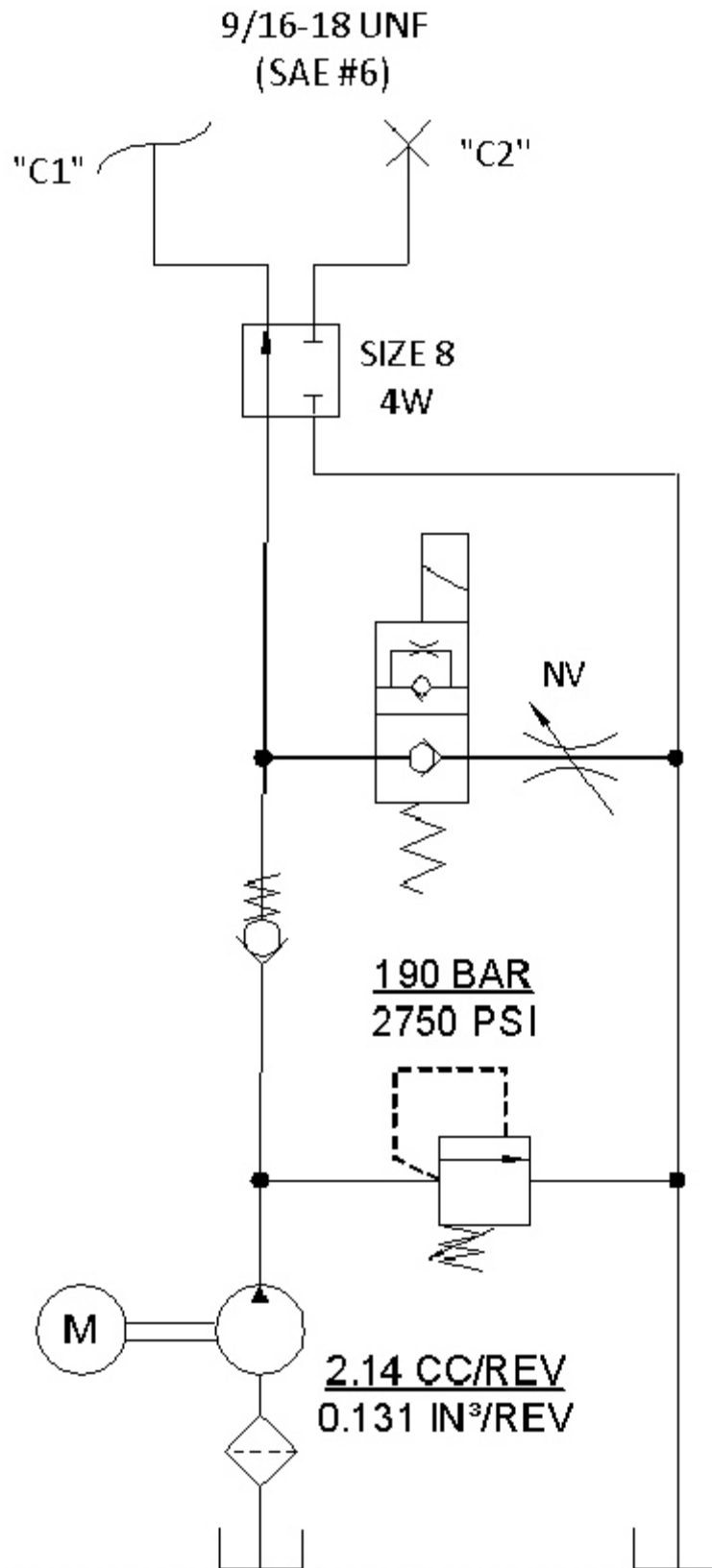

HYDRAULIC BOX DUMPER

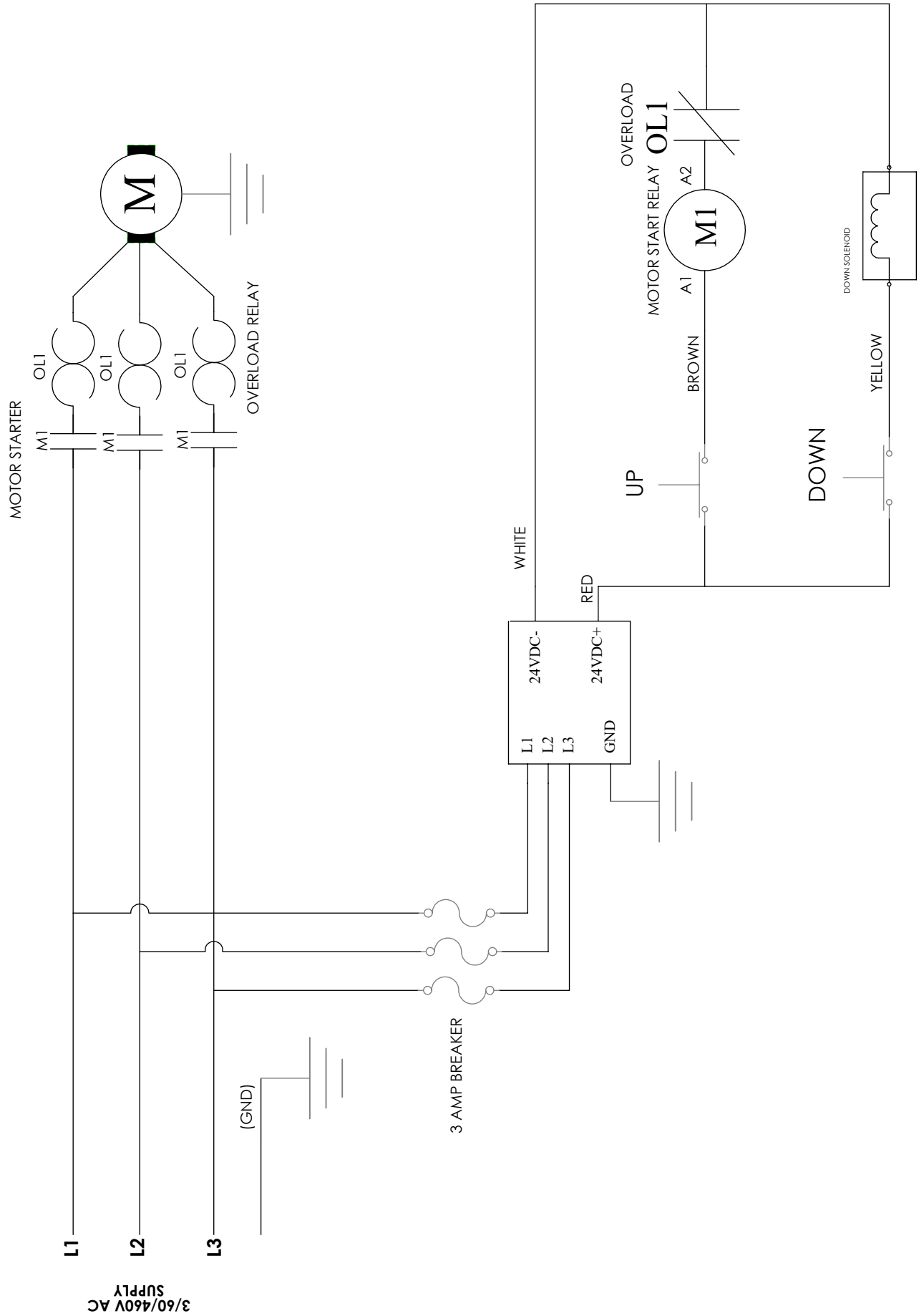

Warranty and Limitation of Liability

Valley Craft products are warranted for a period of one (1) year from date of shipment from Valley Craft's plant to be free from defects in material and workmanship under correct use, normal operation and proper application. However, parts of other than Valley Craft manufacture are subject ONLY to the original manufacturer's warranty. Valley Craft obligation under warranty shall be limited to repair or exchange, at Valley Craft's option, FOB origin factory, of any Valley Craft product or part which proves to be defective as provided herein. Valley Craft reserves the right to either inspect the product at Buyer's location, or require it to be returned to the factory for inspection. The warranty contained herein does not extend to goods damaged, or subject to accident, abuse or misuse after shipment from Valley Craft's factory, nor to goods altered or repaired by anyone other than an authorized Valley Craft representative.

Buyer or user shall not alter, modify or use a Valley Craft product for anything other than its intended function. Valley Craft shall not in any way be responsible for the consequences of any such alteration, modification or misuse.

VALLEY CRAFT MAKES NO EXPRESS WARRANTIES OTHER THAN THOSE WHICH ARE SPECIFICALLY DESCRIBED HEREIN. Any description of the goods sold hereunder, including any references to Buyer's specifications and any descriptions in catalogs, circulars and other written material published by Valley Craft, is for the sole purpose of identifying such goods and shall not create an express warranty that the goods shall conform to such descriptions.

THIS WARRANTY IS EXPRESSLY IN LIEU OF ALL OTHER WARRANTIES, EXPRESS OR IMPLIED. THERE ARE NO IMPLIED WARRANTIES OF MERCHANTABILITY OR FITNESS FOR A PARTICULAR PURPOSE. THIS WARRANTY STATES VALLEY CRAFT'S ENTIRE AND EXCLUSIVE LIABILITY AND BUYER'S EXCLUSIVE REMEDY FOR ANY CLAIM OR DAMAGES IN CONNECTION WITH VALLEY CRAFT PRODUCTS, THEIR DESIGN, SUITABILITY FOR USE, INSTALLATION OR OPERATION OR FOR ANY CLAIMED DEFECTS. VALLEY CRAFT WILL IN NO EVENT BE LIABLE FOR INCIDENTAL OR CONSEQUENTIAL DAMAGES WHATSOEVER, NOR FOR ANY SUM IN EXCESS OF THE PRICE RECEIVED FOR THE GOODS FOR WHICH LIABILITY IS CLAIMED.

Technical Assistance/Warranty Procedure

What's Covered:

- Parts and Labor to correct manufacturer's defect within one year of purchase.
- Freight Cost

What's Not:

- Normal wear items (seal kits, bearings, tires, etc.)

What Voids the Warranty:

- Dirt/Grime that directly causes malfunction of product
 - Abuse (i.e. Overloading, damaged, not properly maintained, etc.)
 - Product altered by customer
- *See "Items not Under Warranty" below for items that have the warranty voided.

Items Under Warranty (less than one year old):

- Warranty replacement parts are provided only when the problem can be identified with near certainty. If not, the customer will return item to Valley Craft, freight collect, for troubleshooting and/or repair. When repaired, product will be returned to customer, freight prepaid. Otherwise, customer may call local authorized service technician for assistance. Under this arrangement, replacement parts will be sent at no charge but labor costs will NOT be covered.

Items NOT Under Warranty (greater than one year old or "having warranty voided):

- Customer will return item to Valley Craft, freight prepaid, for troubleshooting and/or repair. Valley Craft will call customer with \$\$ estimate of parts and labor for approval before repairing. Product will be returned to customer, freight collect.

Or

Customer may call local authorized service technician for repairs at their own expense.



Valley Craft is a family-owned company based in Minnesota. Founded in 1953 with the introduction of the first hand truck with a brake, Valley Craft has grown to be a world class manufacturer known for producing material handling, storage, and safety solutions that truly stand the test of time.

Our commitment to building only the most rugged and reliable products - together with a relentless and uncompromising dedication to customer satisfaction is what sets Valley Craft apart.

Through thoughtful and intelligent design, we have helped transform the way people work. Over the years, we have helped solve some of the most complex material handling challenges. We help our customers to become better organized and to work smarter, safer, and more efficiently. As our breadth of products continues to evolve with every new innovation, our core values stay the same:

Professional Grade Quality.... Built to Last.... Made in the U.S.A.

Valley Craft, Inc.

2001 South Highway 61

Lake City, Minnesota 55401 U.S.A.

www.valleycraft.com 

customerservice@valleycraft.com 

651-345-3386 