



PHT-800# Powered Hand Truck



Unit shown with
Pneumatic Wheels
F89484

Notice to Purchaser

All Statements, technical information, and recommendations related to Valley Craft's products are based on information believed to be reliable, but the accuracy or completeness is not guaranteed. Before using this product, you must determine if it is suitable for your intended application or situation. You assume all risks and liability associated with such use or implementation.

Product Testing

We perform vigorous in-house safety and durability testing to ensure that the performance of our products meets the demands of the workplace. We also expect the same from manufacturers who supply components for our products. We do this to ensure that Valley Craft is a name that our customers trust and associate with quality.

Publication Revision Notice

Following is a history of changes to this publication, including the current revision.

Previously Updated: 07/2025

Last Updated: 01/2026

Copyright Notice

©Valley Craft Industries, Inc. All Rights Reserved. No part of this publication may be reproduced, photocopied, stored on a retrieval system, or transmitted, without the express written consent of Valley Craft Industries, Inc.

Trademarks

The Valley Craft Industries, Inc. logo is a Valley Craft Registered Trademark. All other company or product names are trademarks or registered trademarks of their respective owners. Use of a term in this document should not be regarded as affecting the validity of any trademark or service mark.

Table of Contents

Safety

Safety Overview	4
Safety Message Conventions.....	5
Material Safety Data.....	6

Production Description

Specifications	7
Features	7

Operation

Loading/Unloading Drum	8
Driving the PHT.....	9
Adjusting the Band Brakes	10
Charging the Batteries	10

Maintenance and Adjustments

Maintenance & Adj Procedures.....	11
-----------------------------------	----

Troubleshooting

Troubleshooting Procedures	12-13
----------------------------------	-------

Replacement

Replacement Procedures	13
------------------------------	----

Parts List

Control Box.....	14-15
General & Brake Components	16-18
Electrical Schematic	19

Warranty

Warranty Details	20
------------------------	----

Safety

Read and understand all safety information and become familiar with all safety symbols contained in this section before moving, operating, or performing maintenance on this equipment.

Safety Overview

The following general safety precautions must be observed during all phases of operation, service, and repair of this equipment. Failure to comply with these precautions or with specific safety messages elsewhere in this manual may impair the protection provided by the equipment. Such noncompliance would also violate safety standards of design, manufacture, and intended use of the instrument.

- Observe all safety signs posted in your facility.
- Observe warnings, cautions, handling information, storage requirements, and other information on all container labels.
- Wear safety glasses with side shields.
- Wear the proper protective clothing, gloves, and other protective equipment before handling any chemicals.
- Group the containers for the move by Hazard Class. Do not move acids with toxics or oxidizers.
- Use maximum care and good judgment in preventing accidents and injuries and seeking first aid.
- Report unsafe conditions, equipment, practices, and on-job injuries.
- Understand your supervisor's instructions. Ask questions if you do not know how to do the job safely.
- Do not engage in tasks which you believe might be unsafe without consulting your supervisor.
- Clean up the work area and equipment upon job completion.
- Before you start work on any electrical system or circuit, check all power sources to ensure that the system or circuit is de-energized.
- Know the hazardous or potentially hazardous substances you work with or are present in your work area. Review Material Safety Data Sheets (MSDS) on these substances, or contact your supervisor.

Safety Message Conventions

Three types of safety notices may be contained in this manual: **Danger**, **Warning**, and **Caution** notices. Those notices precede the procedural step or portion of the text that presents the safety hazard.



DANGER

DANGER indicates an imminently hazardous situation which, if not avoided, will result in death or serious injury. This signal word is to be limited to the most extreme situations.



WARNING

WARNING indicates a potentially hazardous situation which, if not avoided, could result in death or serious injury.



CAUTION

CAUTION indicates a potentially hazardous situation which, if not avoided, may result in minor or moderate injury. It may also be used to alert against unsafe practices.

Safety Data Sheets (SDS)

A Safety Data Sheet (SDS) provides information on the safe use, handling, and potential hazards of a product. This information assists with the proper response in the event of an emergency.

Valley Craft Industries, Inc. maintains safety data sheets (SDS) on all our products. You are urged to obtain copies of the relevant SDSs before using our products to protect yourself and others against any known health or safety hazards described in these SDSs. Valley Craft Industries, Inc. strives to make safety a top priority. Do not hesitate to contact us to discuss any safety aspects of our products.

Please contact Valley Craft Customer Service at 651-345-3386 or email (customerservice@valleycraft.com) for SDS Codes for the following Valley Craft products:

- www.batteriesplus.com
- [Paint](#)

Additional Safety Information

As with any mechanical device, care must be taken during the installation, operation, and maintenance of the device in order to realize the maximum benefit from its ownership.

Note: All personnel involved in the use and maintenance of this device should be thoroughly familiar with the information contained in this manual. Furthermore, it is recommended that all personnel be given adequate instruction and a sufficient period of training in its actual use to insure safety of personnel and proper care of the equipment. It is suggested that the units be initially operated empty until becoming familiar with operation of this unit.

Product Description

Valley Craft's **Powered Hand Truck** is a battery powered, 4-wheel drum truck designed to reduce operator strain and fatigue when moving drums.

Specifications

The Powered Hand Truck specifications are shown below in Table 1.

Table 1. Specifications

	F89503 Solid Rubber Wheels	F89484 Pneumatic Wheels
Dimensions	60" H X 26" W X 19-1/2" D	60" H X 27-3/8" W X 20-1/2" D
Weight	150 lbs	160 lbs
Load Capacity	800 lbs	800 lbs

Features

The Powered Hand Truck offers a state-of-the-art design with many advanced features.

- Motor Control with variable forward and reverse speeds
- Powerful transaxle motor with differential drive
- Built-in Battery Charger with Battery Discharge Gauge
- Reverse activated Safety Horn
- Spring-Loaded Chime Hook

Operating Procedures

NOTE: Only trained and authorized personnel are permitted to use the **Powered Hand Truck**.

- **Loading/Unloading Drum**

1. Make sure the chime hook is in the up position.
2. Position the Powered Drum Truck near the drum you wish to load, with the shoes placed securely against the base of the drum.
3. Tip Drum Truck frame up, against the drum to engage the chime hook.
4. Ensure that the chime hook is securely latched against the drum.
5. Break over the drum and allow the truck to rest on all four wheels.
6. Reverse the procedure to unload the drum.

See **FIGURE 1** below for step-by-step procedure.



Step 1: Approach the drum.



Step 2: Place shoes of truck securely against the base of the drum.



Step 3: Tip frame against the drum to engage the chime hook.



Step 4: Break over load and rest on all four wheels.

FIGURE 1: How to Load a Drum
Step-by-step procedure of how to load a drum.

Operating Procedures Continued

- **Driving the Powered Drum Truck**

1. Ensure the drum is secured to the truck.
2. On the control panel, turn the key switch to the on position.
3. Check that the forward/reverse switch is in the proper position for the direction you want to go.
NOTE: An audible horn will sound when the truck is in reverse.
4. With both hands on the handles, twist the throttle to move the truck.
The throttle is a variable speed control for the motor; the more the throttle is twisted, the faster the drum truck will travel.
5. To stop, release the throttle; the electric motor will offer some braking. If necessary, use the hand brake to come to a complete stop.
6. Never operate the Powered Hand Truck on an incline greater than 5-degrees. The braking system may not be able to slow or stop a loaded truck.



WARNING

Always keep both hands on the handles while driving; if the drum contents shift and/or incline changes, the truck may want to brake over. Failure to do so could result in the truck braking over unexpectedly, causing equipment damage and/or physical injury.



WARNING

Never leave the powered drum truck parked on an incline. The electric motor is NOT equipped with a parking brake.

Operating Procedures Continued

- **Adjusting the brake bands**

Valley Craft's Powered Hand Truck is equipped with a band braking system on both drive wheels. When the hand brake is activated, both brake bands clamp down on the drive wheel hubs, causing the truck to slow and stop.

Over time, with use and wear, the band brake tension may need to be adjusted to ensure proper stopping power.

To adjust the brakes:

1. Unload the drum truck.
2. Safely tip the truck over so the drive wheels are off the ground and you have access to the brake bands.
3. There are two methods to adjust the band brake tension; a combination of the two is typically recommended.
 - A. The first method is to adjust the hand brake cable length.
 - I. Loosen the nut and remove the bolt securing the brake cable clevis.
 - II. Screw or unscrew the brake clevis to adjust the cable length as needed.
 - III. Re-attach the brake clevis.
 - B. The second method is to adjust the brake band diameter.
 - I. Loosen the nut on the eccentric brake bolts. (Both Drive Wheels)
 - II. Turn the eccentric brake bolts to adjust the band brake diameter.
 - III. When tensioned properly, re-tighten the nuts to fix the eccentric bolts in place.
4. Tip the truck back onto its wheels and test brake tension; repeat one or both methods if necessary.



CAUTION

Always check that the band brakes on both drive wheels are tensioned evenly before loading the drum truck. Failure to do so can cause unsafe tracking of the drum truck.

- **Charging the Batteries (Built in Charger)**

1. Turn the key on the control panel to the 'OFF' position.
2. Plug a grounded extension cord into the built-in receptacle on control box.
3. The powered hand truck will charge automatically.
4. Once batteries have charged, the extension cord can be removed, and the unit returned to service.

Maintenance and Adjustments

Maintenance and Adjustment Procedures

To keep your Powered Drum Truck operating properly, timely maintenance and adjustments are required. These procedures should be performed only by qualified personnel who are familiar with the equipment.

Maintenance and adjustment procedures are shown in Table 1.

Table 1: Maintenance and Adjustment Procedures

Component	Frequency	Operation	Procedure
Front Drive Wheels (Hard Rubber Option)	Quarterly	Visual Inspection	Inspect drive wheels and axles for signs of wear or damage. Replace hard rubber if necessary.
Front Drive Wheels (Pneumatic Option)	Quarterly	Visual Inspection	Inspect drive wheels and axles for signs of wear or damage. Check pneumatic tire tread and pressure. Replace or fill tire as needed.
Rear Follower Wheels	Quarterly	Visual Inspection	Inspect axle for signs of wear or damage.
	Quarterly	Grease	Pump grease into zerk in both follower wheels.
Hand Brake System	Quarterly	Visual Inspection	Inspect hand brake, clevis, and cable for damage or wear. Ensure brake system is properly adjusted.
	Quarterly	Visual Inspection	Inspect band brakes, eccentric bolts, and nuts for signs of damage or wear, on both drive wheels. Ensure all nuts and bolts are tight.
Front Drive Wheel	Quarterly	Visual Inspection	Inspect bolts securing the drive wheels to the transaxle making sure they are snug. If loose tighten bolts evenly.

Troubleshooting

Troubleshooting Procedures

The Powered Hand Truck is a quality product that is designed and manufactured to provide prolonged service under normal operating conditions. If troubleshooting is required, it should be performed only by qualified personnel who are familiar with the equipment.

Troubleshooting procedures are shown in Table 2.

Table 2: Troubleshooting Procedures

Problem	Possible Cause	Corrective Action
Drum Truck will not run.	Motor not getting power	Ensure key switch is on. Check battery gauge, if battery charge is low, connect charger to appropriate power source.
	Blown Fuse	Check fuse located on control panel. Replace if blown.
	Failed switch or wiring	Check indicator LED on control panel. If flashing, see Table 5 on following page for code information.
	Failed Electric Motor	Check indicator LED on control panel. If flashing, see Table 5 on following page for code information.
Hand Brake not stopping truck.	Brake bands not tensioned properly	See page 10 for instructions on how to properly adjust brake tension.
	Drum truck is overloaded	Remove overload; 800 lbs maximum capacity.
Batteries not charging.	Batteries not hooked up	Check to see that the batteries are both connected.
	Charger setting incorrect	Plug the battery charger in and check to see if the charger is set to 24V and AMG. If it is not unplug the batteries from the charger and use the "Voltage" and "Battery" buttons on the charger to select the correct settings. Re-connect batteries when done .
	Blown charging fuse	Check charger fuse located inside control box. Replace if blown.
Battery Gauge not displaying correctly.	Battery Gauge needs to be reset	Turn key switch "ON" and leave on for 15-20 minutes or until the battery gauge resets and displays correctly

The Powered Hand Truck is equipped with an LED Indicator light that will display fault codes if a problem occurs. See Table 5 below for fault code information and possible causes.

Use this table as a guide when troubleshooting problems and contact Valley Craft for additional information. *Table 3: Indicator LED Fault Codes*

LED Codes	Sequence	Explanation
LED off	-	No power or damaged controller.
LED Solid On	-	Unit Operational; No faults.
1,1	□ □ Thermal Cutback	Excessive Load on Truck; Operating in Extreme Environment.
1,2	□ □□ Throttle Fault	Throttle Input Wire open or shorted; Throttle damaged.
1,3	□ □□□ Speed Limit Pot Fault	Speed Limit pot wires broken or shorted.
1,4	□ □□□□ Under voltage Fault	Battery Voltage <17V; Battery Connection Bad or Damaged.
1,5	□ □□□□□ Over voltage Fault	Battery Voltage >36V; Vehicle Operating with charger attached.
4,1	□□□□ □ Current Sense Fault	Short in motor or in motor wiring.

Replacement

Replacement Procedures

Occasionally, it will be necessary to replace a part that has been damaged or worn. Many parts on Valley Craft’s Powered Hand Truck are replaceable. If replacement of a part is required, it should be performed only by qualified personnel who are familiar with the equipment.

See Pages 14, 15, 16, 17, & 18 for available replacement parts. Identify the part number you need.

Contact Valley Craft Customer Service at 1-651-345-3386 or email: customerservice@valleycraft.com.

Information required when contacting Valley Craft:

- Company name and address
- Contact person’s name
- Telephone number
- E-Mail address
- Model Number
- Date of Manufacture
- Part number(s) of part(s) to be ordered

The model number and date of manufacture is stamped on a metal tag located on the top back band of the Powered Hand Truck.

Parts Breakdown CONTROL BOX F69046A6

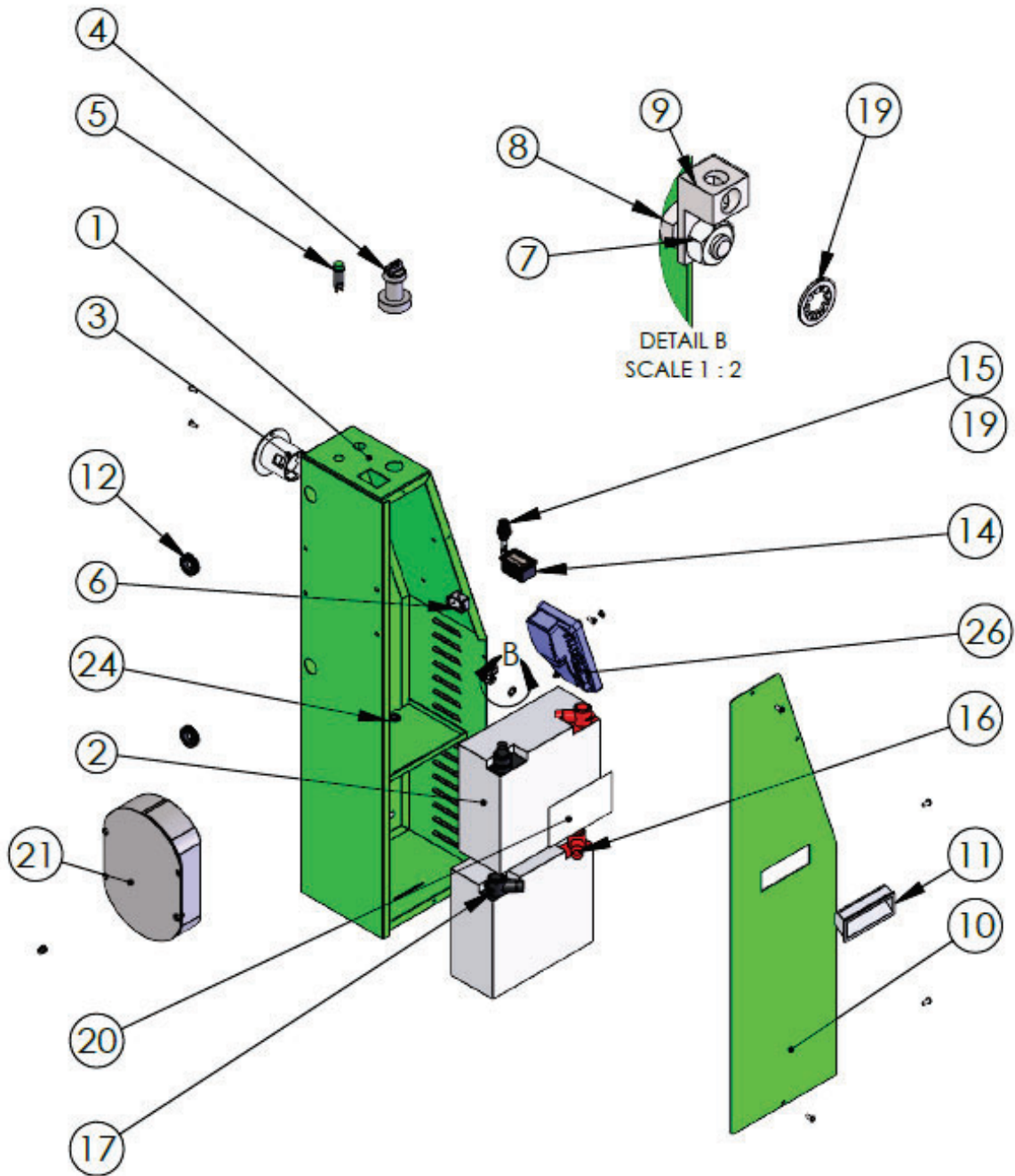

SEE FOLLOWING PAGE FOR PARTS LIST

Parts Breakdown
CONTROL BOX
 F69046A6

ITEM NO.	PART NUMBER	DESCRIPTION	Default/QTY.
1	F69448A4	PHT CONTROL BOX WLDMT	1
2	Z00558A4	BATTERY-12V 18AH	2
3	Z00120A4	PLUG-FLGD INLET 125V	1
4	Z00561A7	SWITCH-KEY ON/OFF 24VDC PT, MFR # 84828-07	1
5	Z20817A6	LIGHT-INDICATOR LED GRN 24V	1
6	Z11613A8	BUZZER-24VDC FLANGE MNT	1
7	Z10035A7	NUT-HEX KEPS 1/4-20	1
8	Z10109A8	S-HHC 1/4-20X1/2	1
9	Z10708A3	LUG-SET SCREW 1/4	1
10	F51823	CONTROL BOX COVER	1
11	Z30415A5	HDL PCKT PULL PLST 3.25X1.41	1
12	Z00116A0	GROMMET-.625ID SBR	2
14	Z00584A0	CURTIS BATTERY DISCHARGE GAUGE	1
15	Z00530A0	FUSE HOLDER PANEL MNT	1
16	Z00594A0	BATT TERM COVER RD	2
17	Z00595A1	BATT TERM COVER BLK	2
18	Z00613A9	FUSE-AGC 30 AMP	1
19	Z10207A9	WASHER-1/4 LOCK INT TOOTH	1
20	Z40998A9	DECAL-12V BATTERY	1
21	Z20361A1	BATTERY CHARGER, DELTRAN 12/24v	1
24	Z00148A2	GROMMET 1/2 DIA	1
25	A37308-39	S-BHSC #8-32X1-1/8	2
26	Z20960A5	CURTIS MTR CNTLR 1212 PROG-PHT	1

GENERAL AND BRAKE COMPONENT PARTS

F89503 & F89484 SHARED PARTS

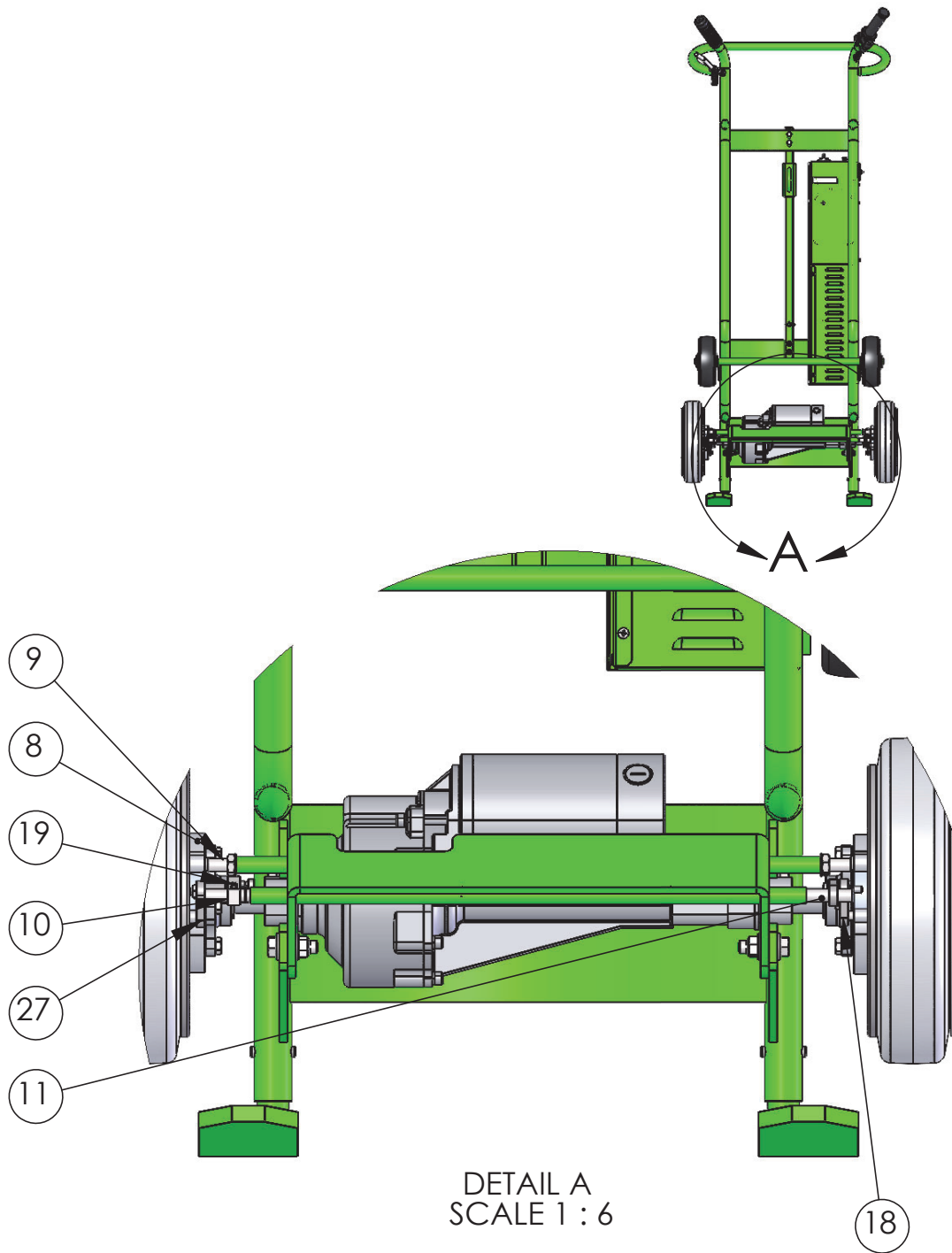

DETAIL A
SCALE 1 : 6

PHT-800#

ITEM NO.	PART NUMBER	DESCRIPTION	Default/QTY.
1	F69044A4	PHT-800#-FRAME WLD	1
2	Z20912A7	TRANSAXLE-0.44HP/14" FLANGE	1
3	Z00591A7	THROTTLE TWIST MAGURA 0-5K	1
4	Z00592A8	SWITCH-MOTOR REVERSE	1
5	Z50007A7	GRIP-HDL 1-1/8" BLK	1
6	F69046A6	PHT CONTROL BOX ASSEMBLY	1
7	Z10236A4	RING-RTNG 3/4 5304	2
8	F62177A2	BRK BAND ASSY	2
9	Z30012A2	ECC-BRK SHORT	2
10	F51830	LINK-BRAKE ROD PHT (kan ban)	1
11	F69455A1	BRK ROD WLDMT-PHT	1
12	F30013A7	HDL-BRK/825 (KAN BAN)	1
13	F30014A6	CLEVIS-BRK CABLE (KAN BAN)	1
14	F69456A2	MOTOR MT WLDMT	1
15	F60045A6	SHOE WLDMT-LH S/600	1
16	F60044A7	SHOE WLDMT-RH S/600	1
17	F60039B2	CHIME HOOK ASSY - STEEL --CS, use R60039 for RPMS	1
18	F69051A1	BRK LINKAGE WLDMT	1
19	Z10069A6	PIN-SPG 3/16X5/8	1
20	Z10076A7	PIN-SPG 5/16X1-3/8	2
21	Z10511A7	S-CRG 5/16-18x3/4	4
22	Z10036A6	NUT-HEX KEPS 5/16-18	8
23	Z42247A8	DECAL-FULLY CHARGE BATT	1
24	Z41156A5	LABEL-VALLEYCRAFT PAPER	1
25	Z10122A1	S-HHC 5/16-18X3/4	2
26	Z10125A8	S-HHC 5/16-18X1-1/2	2
27	F69457A3	EXTENDED BRK LINKAGE WLDMT	1
28	Z51674A4	KEY-3/16X1-1/2	1

F89484 SPECIFIC PARTS

ITEM NO.	PART NUMBER	DESCRIPTION	QTY
30	F51841	WHL-12 PHT MACH	2
31	Z31626A5	WHL-8X2-1/2 HD RBR	2

F89503 SPECIFIC PARTS

ITEM NO.	PART NUMBER	DESCRIPTION	QTY
32	F69458A4	WHL 10x2-1/2-PHT	2
33	Z30135A4	WHL-6 x 2 U/P 3/4	2

PARTS BREAKDOWN
GENERAL

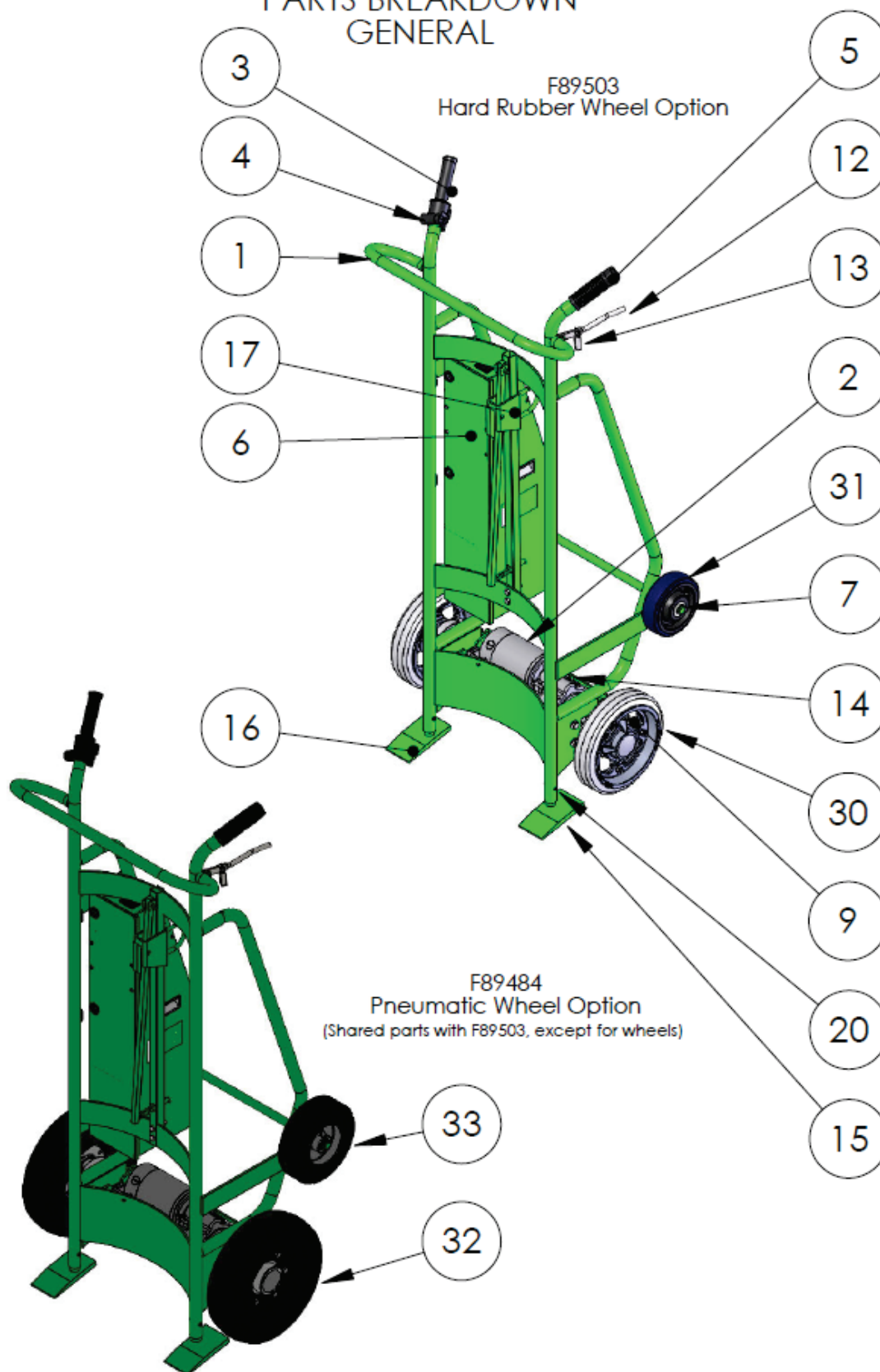

ELECTRICAL SCHEMATIC

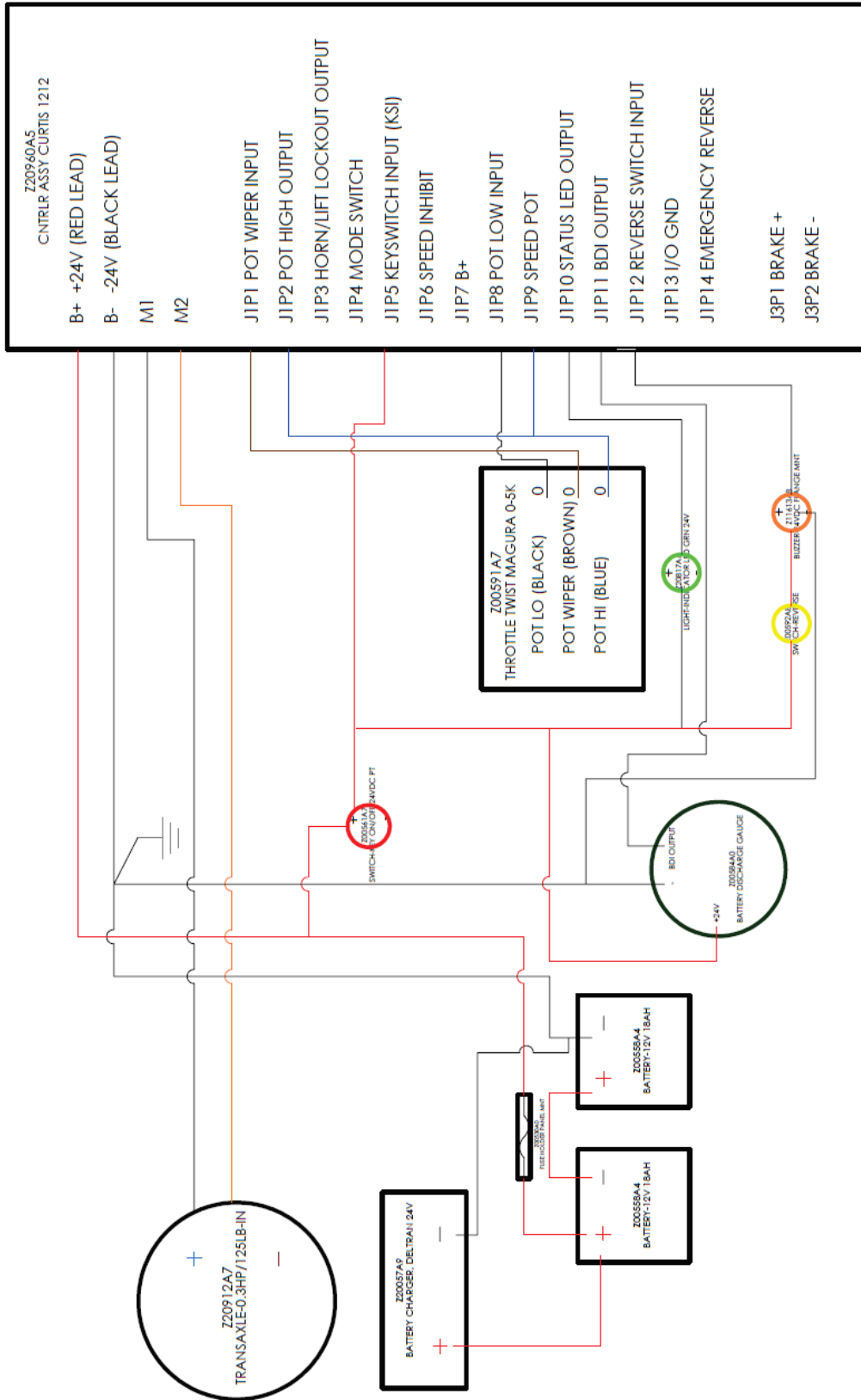

Warranty and Limitation of Liability

Valley Craft Industries, Inc. products are warranted for a period of one (1) year from date of shipment from Valley Craft's plant to be free from defects in material and workmanship under correct use, normal operation and proper application. However, parts of other than Valley Craft manufacture are subject ONLY to the original manufacturer's warranty. Valley Craft's obligation under warranty shall be limited to repair or exchange, at Valley Craft's option, FOB factory origin, of any Valley Craft product or part which proves to be defective as provided herein. Valley Craft reserves the right to either inspect the product at Buyer's location, or require it to be returned to the factory for inspection. The warranty contained herein does not extend to goods damaged, or subject to accident, abuse or misuse after shipment from Valley Craft's factory, nor to goods altered or repaired by anyone other than an authorized Valley Craft representative.

Buyer or user shall not alter, modify or use a Valley Craft product for anything other than its intended function. Valley Craft shall not in any way be responsible for the consequences of any such alteration, modification or misuse.

VALLEY CRAFT MAKES NO EXPRESS WARRANTIES OTHER THAN THOSE WHICH ARE SPECIFICALLY DESCRIBED HEREIN. Any description of the goods sold hereunder, including any references to Buyer's specifications and any descriptions in catalogs, circulars and other written material published by Valley Craft, is for the sole purpose of identifying such goods and shall not create an express warranty that the goods shall conform to such descriptions.

THIS WARRANTY IS EXPRESSLY IN LIEU OF ALL OTHER WARRANTIES, EXPRESS OR IMPLIED. THERE ARE NO IMPLIED WARRANTIES OF MERCHANTABILITY OR FITNESS FOR A PARTICULAR PURPOSE. THIS WARRANTY STATES VALLEY CRAFT'S ENTIRE AND EXCLUSIVE LIABILITY AND BUYER'S EXCLUSIVE REMEDY FOR ANY CLAIM OR DAMAGES IN CONNECTION WITH VALLEY CRAFT PRODUCTS, THEIR DESIGN. SUITABILITY FOR USE, INSTALLATION OR OPERATION OR FOR ANY CLAIMED DEFECTS. VALLEY CRAFT WILL IN NO EVENT BE LIABLE FOR INCIDENTAL OR CONSEQUENTIAL DAMAGES WHATSOEVER, NOR FOR ANY SUM IN EXCESS OF THE PRICE RECEIVED FOR THE GOODS FOR WHICH LIABILITY IS CLAIMED.

Technical Assistance/Warranty Procedure

What's Covered:

- Parts and Labor to correct manufacturer's defect within one year of purchase.
- Freight Cost

What's Not:

- Normal wear items (seal kits, bearings, tires, etc.)

What Voids the Warranty:

- Dirt/Grime that directly causes malfunction of product
 - Abuse (i.e. Overloading, damaged, not properly maintained, etc.)
 - Product altered by customer
- *See "Items not Under Warranty" below for items that have the warranty voided.

Items Under Warranty (less than one year old):

- Warranty replacement parts are provided only when the problem can be identified with near certainty. If not, the customer will return item to Valley Craft, freight collect, for troubleshooting and/or repair. When repaired, product will be returned to customer, freight prepaid. Otherwise, customer may call local authorized service technician for assistance. Under this arrangement, replacement parts will be sent at no charge but labor costs will NOT be covered.

Items NOT Under Warranty (greater than one year old or *having warranty voided):

- Customer will return item to Valley Craft, freight prepaid, for troubleshooting and/or repair. Valley Craft will call customer with \$\$ estimate of parts and labor for approval before repairing. Product will be returned to customer, freight collect.

OR

- Customer may call local authorized service technician for repairs at their own expense.



Valley Craft is a modern metals fabricating manufacturer specializing in material handling, storage and specialized solutions designed with safety and usability in mind, and the simplification of even the heaviest of workloads. Since developing the first hand truck with a brake in 1952, Valley Craft has been a true pioneer in safety-conscious material handling and solution-driven products. Our commitment to continuous improvement in a Lean Manufacturing environment results in safe, functional, quality equipment at affordable prices.

Valley Craft Industries, Inc.

2001 South Highway 61
Lake City, MN 55041 U.S.A.

Phone: (651) 345-3386

Fax: (651) 345-6535

E-Mail: customerservice@valleycraft.com

Website: valleycraft.com